

February 24, 2023

**BY ELECTRONIC FILING**

Mr. Bernard Logan, Clerk  
c/o Document Control Center  
State Corporation Commission  
1300 East Main Street  
Tyler Building – 1st Floor  
Richmond, Virginia 23219

*Application of Virginia Electric and Power Company for  
approval and certification of electric transmission facilities:  
Lines #2019 and #2007 Rebuild Project*  
**Case No. PUR-2023-00023**

Dear Mr. Logan:

Please find enclosed for electronic filing in the above-captioned proceeding the application for approval of electric facilities on behalf of Virginia Electric and Power Company (the “Company”). This filing contains the Application, Appendix, Direct Testimony, and DEQ Supplement, including attachments.

As indicated in Section II.A.12.b of the Appendix, an electronic copy of the map of the Virginia Department of Transportation “General Highway Map” for the City of Virginia Beach, as well as the digital geographic information system (“GIS”) map required by § 56-46.1 of the Code of Virginia, which is Attachment II.A.2 to the Appendix, were provided via an e-room to the Commission’s Division of Public Utility Regulation on February 22, 2023.

Please do not hesitate to call if you have any questions in regard to the enclosed.

Very truly yours,



Vishwa B. Link

Enclosures

cc: William H. Chambliss, Esq.  
Mr. David Essah (without enclosures)

Mr. Bernard Logan, Clerk  
February 24, 2023  
Page 2

Mr. Neil Joshipura (without enclosures)  
Mr. Michael A. Cizenski (without enclosures)  
David J. DePippo, Esq.  
Annie C. Larson, Esq.  
Jennifer D. Valaika, Esq.  
Anne Hampton Haynes, Esq.  
Briana M. Jackson, Esq.



**Dominion  
Energy<sup>®</sup>**

**Application, Appendix,  
DEQ Supplement, Direct  
Testimony and Exhibits of  
Virginia Electric and Power  
Company**

**Before the State Corporation  
Commission of Virginia**

**Lines #2019 and #2007 Rebuild  
Project**

**Application No. 321**

**Case No. PUR-2023-00023**

**Filed: February 24, 2023**

**Volume 1 of 2**

COMMONWEALTH OF VIRGINIA  
BEFORE THE  
STATE CORPORATION COMMISSION

APPLICATION OF  
VIRGINIA ELECTRIC AND POWER COMPANY  
FOR APPROVAL AND CERTIFICATION  
OF ELECTRIC TRANSMISSION FACILITIES  
**Lines #2019 and #2007 Rebuild Project**

Application No. 321

Case No. PUR-2023-00023

Filed: February 24, 2023

COMMONWEALTH OF VIRGINIA

STATE CORPORATION COMMISSION

APPLICATION OF	)	
	)	
VIRGINIA ELECTRIC AND POWER COMPANY	)	Case No. PUR-2023-00023
	)	
For approval and certification of electric	)	
transmission facilities: Lines #2019	)	
and #2007 Rebuild Project	)	

**APPLICATION OF VIRGINIA ELECTRIC AND POWER COMPANY  
FOR APPROVAL AND CERTIFICATION OF  
ELECTRIC TRANSMISSION FACILITIES:  
LINES #2019 AND #2007 REBUILD PROJECT**

Pursuant to § 56-46.1 of the Code of Virginia (“Va. Code”) and the Utility Facilities Act, Va. Code § 56-265.1 *et seq.*, Virginia Electric and Power Company (“Dominion Energy Virginia” or the “Company”), by counsel, files with the State Corporation Commission of Virginia (the “Commission”) this application for approval and certification of electric transmission facilities (the “Application”). In support of its Application, Dominion Energy Virginia respectfully shows as follows:

1. Dominion Energy Virginia is a public service corporation organized under the laws of the Commonwealth of Virginia furnishing electric service to the public within its Virginia service territory. The Company also furnishes electric service to the public in portions of North Carolina. Dominion Energy Virginia’s electric system—consisting of facilities for the generation, transmission, and distribution of electric energy—is interconnected with the electric systems of neighboring utilities and is a part of the interconnected network of electric systems serving the continental United States. By reason of its operation in two states and its interconnections with other utilities, the Company is engaged in interstate commerce.

2. In order to perform its legal duty to furnish adequate and reliable electric service, Dominion Energy Virginia must, from time to time, replace existing transmission facilities or construct new transmission facilities in its system.

3. In this Application, in order to maintain the structural integrity and reliability of its transmission system in compliance with the Company's mandatory electric transmission planning criteria ("Planning Criteria")<sup>1</sup> and consistent with sound engineering judgment, Dominion Energy Virginia proposes the following rebuild project located within existing right-of-way or on Company-owned property along an approximately 4.54-mile existing transmission corridor in the City of Virginia Beach, Virginia (the "Rebuild Project"):

- Rebuild an approximately 1.17-mile segment of 230 kV Greenwich-Thalia Line #2019 from Structure #2019/20 to the Company's existing Thalia Substation. Specifically, replace 1.17 miles of Line #2019 structures beginning at Structure #2019/21, which primarily are single circuit concrete monopoles, with single circuit galvanized steel monopoles on concrete foundations. Additionally, replace conductors between Structure #2019/20 and the Thalia Substation, and replace shield wires between Greenwich Substation and Thalia Substation with two fiber optic shield wires.<sup>2</sup>
- Rebuild the entire approximately 3.37-mile 230 kV Lynnhaven-Thalia Line #2007 between the Company's existing Lynnhaven and Thalia Substations. Specifically, replace 3.37 miles of Line #2007 structures between Structure #2007/102 and Structure #2007/42A, which primarily are single circuit concrete monopoles, with single circuit galvanized steel

---

<sup>1</sup> The Company's Transmission Planning Criteria (effective April 1, 2021) can be found in Attachment 1 of the Company's Facility Interconnection Requirements ("FIR") document, which is available online at <https://cdn-dominionenergy-prd-001.azureedge.net/-/media/pdfs/virginia/parallel-generation/facility-connection-requirements.pdf?la=en&rev=f280781e90cf47f69ea526c944c9c347&hash=82DD2567D0B033C47536134B8C4D5C5E>.

<sup>2</sup> While required by the proposed Rebuild Project and included in the total costs of the Rebuild Project, the Company considers the replacement of the existing shield wires with fiber optic shield wires between Structure #2019/20 and the Greenwich Substation—which will provide redundancy and physically diverse communications across the Company's substations in the Rebuild Project area—to qualify as "ordinary extensions or improvements in the usual course of business" pursuant to § 56-265.2 A 1 of the Code of Virginia ("Va. Code") and therefore, does not require approval pursuant to Va. Code § 56-46.1 B or a certificate of public convenience and necessity ("CPCN") from the State Corporation Commission (the "Commission"). This is consistent with the Commission Staff's July 6, 2017 guidance, as it would not require the replacement of any structures and would only require replacement of existing shield wires. Accordingly, while this work is a component of this Rebuild Project, the Company does not believe that a CPCN is required for this work between Structure #2019/20 and the Greenwich Substation. Should the Commission determine that a CPCN is required for the fiber optic shield work associated with Line #2019 between Structure #2019/20 and Greenwich Substation as described herein, the Company requests that the Commission grant such CPCN as part of its final order in this proceeding.

monopoles on concrete foundations. Additionally, between Greenwich Substation and Thalia Substation, replace conductors, and replace shield wires with two fiber optic shield wires.

- Conduct related work at the Company's existing Greenwich, Thalia and Lynnhaven Substations to support the new line ratings.

4. The proposed Rebuild Project will replace aging infrastructure that is at the end of its service life. Specifically, the Rebuild Project will rebuild approximately 1.17 miles of the 230 kV Greenwich-Thalia Line #2019 between Structure #2019/20 and the Thalia Substation, which was constructed on concrete structures in 1970, and the entire 3.37 miles of the 230 kV Lynnhaven-Thalia Line #2007, which was constructed on concrete structures in 1970. These concrete structures have developed significant structural concerns as they age and have been identified for rebuild based on the Company's end-of-life criteria. In addition to the concrete structures, industry guidelines indicate equipment life for conductor and connectors are 40-60 years, and porcelain insulators are 50 years. The combination of deteriorating condition and age indicate that these structures and line equipment have reached their end of life.

5. In summary, the proposed Rebuild Project will replace aging infrastructure at the end of its service life in compliance with the Company's mandatory Planning Criteria and consistent with sound engineering judgment, thereby enabling the Company to maintain the overall long-term reliability of its transmission system, as well as provide important system reliability benefits to the Company's entire network.

6. The desired in-service date for the Rebuild Project is December 31, 2025. The Company estimates it will take approximately 28 months for detailed engineering, materials procurement, permitting, and construction after a final order from the Commission. Accordingly, to support this estimated pre-construction activity timeline and construction plan, the Company respectfully requests a final order by September 1, 2023. Should the Commission issue a final

order by September 1, 2023, the Company estimates that construction should begin in July 2024, and be completed in December 2025. This construction timeline will enable the Company to meet the targeted in-service date for the Rebuild Project. This schedule is contingent upon obtaining the necessary permits and outages. Dates may need to be adjusted based on permitting delays or design modifications to comply with additional agency requirements identified during the permitting application process, as well as the ability to schedule outages or unpredictable delays due to labor shortages and/or materials/supply issues based on other extensive project work ongoing in the vicinity of the Rebuild Project.

7. The estimated conceptual cost of the proposed Rebuild Project is approximately \$91.1 million, which includes approximately \$87.4 million for transmission-related work and approximately \$3.7 million for substation-related work (2022 dollars). The description of the proposed Rebuild Project is described in detail in Sections I and II of the Appendix attached to this Application.

8. The total length of the existing right-of-way and Company-owned property to be used for the Rebuild Project is approximately 4.54 miles. Because the existing right-of-way and Company-owned property are adequate for the proposed Rebuild Project, no new right-of-way is required. Given the availability of existing right-of-way and the statutory preference given to use of existing rights-of-way, and because additional costs and environmental impacts would be associated with the acquisition of and construction on new right-of-way, the Company did not consider any alternate routes requiring new right-of-way for this Rebuild Project.

9. Based on consultations with the Virginia Department of Environmental Quality (“DEQ”), the Company has developed a supplement (“DEQ Supplement”) containing information designed to facilitate review and analysis of the proposed facilities by the DEQ and other relevant

agencies. The DEQ Supplement is attached to this Application.

10. Based on the Company's experience, the advice of consultants, and a review of published studies by experts in the field, the Company believes that there is no causal link to harmful health or safety effects from electric and magnetic fields generated by the Company's existing or proposed facilities. Section IV of the Appendix provides further details on Dominion Energy Virginia's consideration of the health aspects of electric and magnetic fields.

11. Section V of the Appendix provides a proposed route description for public notice purposes and a list of federal, state, and local agencies and officials that the Company has or will notify about the Application.

12. In addition to the information provided in the Appendix and the DEQ Supplement, this Application is supported by the pre-filed direct testimony of Company Witnesses Samuel L. Carter, Trey M. Rydel, Antoaneta Yanev, and Charles H. Weil filed with this Application.

13. As this Application seeks approval to rebuild an existing line entirely within existing right-of-way, the Company respectfully requests, in the interest of judicial economy, that the Commission issue an Order for Notice and Comment setting forth a procedural schedule in this proceeding without a scheduled evidentiary hearing, but with an opportunity for interested persons to request an evidentiary hearing if the issues raised cannot be addressed adequately without a hearing. An Order for Notice and Comment will still allow the Company, Commission Staff, and any interested parties that join the proceeding to develop a complete record without prejudice, as Staff or any party may file with the Commission a request for hearing.

WHEREFORE, Dominion Energy Virginia respectfully requests that the Commission:

(a) direct that notice of this Application be given as required by § 56-46.1 of the Code of Virginia;

(b) approve pursuant to § 56-46.1 of the Code of Virginia the construction of the Rebuild Project; and,

(c) grant a certificate of public convenience and necessity for the Rebuild Project under the Utility Facilities Act, § 56-265.1 *et seq.* of the Code of Virginia.

**VIRGINIA ELECTRIC AND POWER COMPANY**

By:           /s/          Vishwa B. Link            
Counsel for Applicant

David J. DePippo  
Annie C. Larson  
Dominion Energy Services, Inc.  
120 Tredegar Street  
Richmond, Virginia 23219  
(804) 819-2411 (DJD)  
(804) 819-2806 (ACL)  
*david.j.depippo@dominionenergy.com*  
*annie.c.larson@dominionenergy.com*

Vishwa B. Link  
Jennifer D. Valaika  
Anne Hampton Haynes  
Briana M. Jackson  
McGuireWoods LLP  
Gateway Plaza  
800 E. Canal Street  
Richmond, Virginia 23219  
(804) 775-4330 (VBL)  
(804) 775-1051 (JDV)  
(804) 775-4395 (AHH)  
(804) 775-1323 (BMJ)  
*vlink@mcguirewoods.com*  
*jvalaika@mcguirewoods.com*  
*ahaynes@mcguirewoods.com*  
*bmjackson@mcguirewoods.com*

*Counsel for Applicant Virginia Electric and Power Company*

February 24, 2023

COMMONWEALTH OF VIRGINIA  
BEFORE THE  
STATE CORPORATION COMMISSION

APPLICATION OF  
VIRGINIA ELECTRIC AND POWER COMPANY  
FOR APPROVAL AND CERTIFICATION  
OF ELECTRIC TRANSMISSION FACILITIES

Lines #2019 and #2007 Rebuild Project

Application No. 321

Appendix

Containing Information in Response to  
“Guidelines for Transmission Line Applications Filed Under Title 56 of the Code of Virginia”

Case No. PUR-2023-00023

Filed: February 24, 2023

## TABLE OF CONTENTS

Executive Summary .....	i
I. Necessity for the Proposed Project .....	1
II. Description of the Proposed Project .....	139
III. Impact of Line on Scenic, Environmental and Historic Features .....	190
IV. Health Aspects of EMF.....	228
V. Notice.....	247

## EXECUTIVE SUMMARY

In order to maintain the structural integrity and reliability of its transmission system in compliance with the Company's mandatory electric transmission planning criteria ("Planning Criteria")<sup>1</sup> and consistent with sound engineering judgment, Virginia Electric and Power Company ("Dominion Energy Virginia" or the "Company") proposes the following rebuild project located within existing right-of-way or on Company-owned property along an approximately 4.54-mile transmission corridor in the City of Virginia Beach, Virginia (the "Rebuild Project"):

- Rebuild an approximately 1.17-mile segment of 230 kV Greenwich-Thalia Line #2019 from Structure #2019/20 to the Company's existing Thalia Substation. Specifically, replace the existing Line #2019 structures between Structure #2019/21 and Thalia Substation, which primarily are single circuit concrete monopoles, with single circuit galvanized steel monopoles on concrete foundations. Additionally, replace conductors between Structure #2019/20 and the Thalia Substation, and replace shield wires between Greenwich Substation and Thalia Substation with two fiber optic shield wires.<sup>2</sup>
- Rebuild the entire approximately 3.37-mile 230 kV Lynnhaven-Thalia Line #2007 between the Company's existing Lynnhaven and Thalia Substations. Specifically, replace the existing Line #2007 structures between Structure #2007/102 and Structure #2007/42A, which primarily are single circuit concrete monopoles, with single circuit galvanized steel monopoles on concrete foundations. Additionally, between Greenwich Substation and Thalia Substation, replace conductors, and replace shield wires with two fiber optic shield wires.
- Conduct related work at the Company's existing Greenwich, Thalia and Lynnhaven Substations to support the new line ratings.

The proposed Rebuild Project will replace aging infrastructure that is at the end of its service life. Specifically, the Rebuild Project will rebuild approximately 1.17 miles of the 230 kV Greenwich-Thalia Line #2019 between Structure #2019/20 and the Thalia Substation, which was constructed

---

<sup>1</sup> The Company's Transmission Planning Criteria (effective April 1, 2021) can be found in Attachment 1 of the Company's Facility Interconnection Requirements ("FIR") document, which is available online at <https://cdn-dominionenergy-prd-001.azureedge.net/-/media/pdfs/virginia/parallel-generation/facility-connection-requirements.pdf?la=en&rev=f280781e90cf47f69ea526c944c9c347&hash=82DD2567D0B033C47536134B8C4D5C5E>.

<sup>2</sup> While required by the proposed Rebuild Project and included in the total costs of the Rebuild Project, the Company considers the replacement of the existing shield wires with fiber optic shield wires between Structure #2019/20 and the Greenwich Substation—which will provide redundancy and physically diverse communications across the Company's substations in the Rebuild Project area—to qualify as "ordinary extensions or improvements in the usual course of business" pursuant to § 56-265.2 A 1 of the Code of Virginia ("Va. Code") and therefore, does not require approval pursuant to Va. Code § 56-46.1 B or a certificate of public convenience and necessity ("CPCN") from the State Corporation Commission (the "Commission"). This is consistent with the Commission Staff's July 6, 2017 guidance, as it would not require the replacement of any structures and would only require replacement of existing shield wires. Accordingly, while this work is a component of this Rebuild Project, the Company does not believe that a CPCN is required for this work between Structure #2019/20 and the Greenwich Substation. Should the Commission determine that a CPCN is required for the fiber optic shield work associated with Line #2019 between Structure #2019/20 and Greenwich Substation as described herein, the Company requests that the Commission grant such CPCN as part of its final order in this proceeding.

on concrete structures in 1970, and the entire 3.37 miles of the 230 kV Lynnhaven-Thalia Line #2007, which was constructed on concrete structures in 1970. These concrete structures have developed significant structural concerns as they age and have been identified for rebuild based on the Company's end-of-life criteria.

In addition to the concrete structures, industry guidelines indicate equipment life for conductor and connectors are 40-60 years, and porcelain insulators are 50 years. The combination of deteriorating condition and age indicate that these structures and line equipment have reached their end of life.

In summary, the proposed Rebuild Project will replace aging infrastructure at the end of its service life in compliance with the Company's mandatory Planning Criteria and consistent with sound engineering judgment, thereby enabling the Company to maintain the overall long-term reliability of its transmission system, as well as provide important system reliability benefits to the Company's entire network.

The total length of the existing right-of-way and Company-owned property to be used for the Rebuild Project is approximately 4.54 miles. Because the existing right-of-way and Company-owned property are adequate for the proposed Rebuild Project, no new right-of-way is required. Given the availability of existing right-of-way and the statutory preference given to use of existing rights-of-way, and because additional costs and environmental impacts would be associated with the acquisition of and construction on new right-of-way, the Company did not consider any alternate routes requiring new right-of-way for the Rebuild Project.

The total estimated conceptual cost of the Rebuild Project is approximately \$91.1 million, which includes approximately \$87.4 million for transmission-related work, and approximately \$3.7 million for substation-related work (2022 dollars).

The desired in-service date for the Rebuild Project is December 31, 2025. The Company estimates it will take approximately 28 months for detailed engineering, materials procurement, permitting, and construction after a final order from the Commission. Accordingly, to support this estimated pre-construction activity timeline and construction plan, the Company respectfully requests a final order by September 1, 2023. Should the Commission issue a final order by September 1, 2023, the Company estimates that construction should begin in July 2024 and be completed in December 2025. This construction timeline will enable the Company to meet the targeted in-service date for the Rebuild Project. This schedule is contingent upon obtaining the necessary permits and outages. Dates may need to be adjusted based on permitting delays or design modifications to comply with additional agency requirements identified during the permitting application process, as well as the ability to schedule outages or unpredictable delays due to labor shortages and/or materials/supply issues based on other extensive project work ongoing in the vicinity of the Rebuild Project.

## I. NECESSITY FOR THE PROPOSED PROJECT

- A. State the primary justification for the proposed project (for example, the most critical contingency violation including the first year and season in which the violation occurs). In addition, identify each transmission planning standard(s) (of the Applicant, regional transmission organization (“RTO”), or North American Electric Reliability Corporation) projected to be violated absent construction of the facility.**

Response: The proposed Rebuild Project is necessary to replace aging infrastructure that is at the end of its service life along an approximately 1.17-mile segment of 230 kV Greenwich-Thalia Line #2019 and along the entire 3.37-mile 230 kV Thalia-Lynnhaven Line #2007 in the City of Virginia Beach, Virginia. See Attachment I.A.1 for an overview map of the proposed Rebuild Project.

Dominion Energy Virginia’s transmission system is responsible for providing transmission service: (i) for redelivery to the Company’s retail customers; (ii) to Appalachian Power Company, Old Dominion Electric Cooperative, Northern Virginia Electric Cooperative, Central Virginia Electric Cooperative, and Virginia Municipal Electric Association for redelivery to their retail customers in Virginia; and (iii) to North Carolina Electric Membership Corporation and North Carolina Eastern Municipal Power Agency for redelivery to their customers in North Carolina (collectively, the “Dominion Energy Zone” or “DOM Zone”).

Dominion Energy Virginia is part of the PJM Interconnection, L.L.C. (“PJM”) regional transmission organization, which provides service to a large portion of the eastern United States. PJM currently is responsible for ensuring the reliability of and coordinating the movement of electricity through all or parts of Delaware, Illinois, Indiana, Kentucky, Maryland, Michigan, New Jersey, North Carolina, Ohio, Pennsylvania, Tennessee, Virginia, West Virginia, and the District of Columbia. This service area has a population of approximately 65 million and on August 2, 2006, set a record high of 166,929 megawatts (“MW”) for summer peak demand, of which Dominion Energy Virginia’s load portion was approximately 19,256 MW serving 2.4 million customers. On August 9, 2022, the Company set a record high of 21,156 MW for summer peak demand. On December 24, 2022, the Company set a winter peak and all-time record demand of 22,189 MW. Based on the 2023 PJM Load Forecast, the Dominion Energy Zone is expected to grow with average growth rates of 5.0% summer and 4.8% winter over the next 10 years compared to the PJM average of 0.8% and 1.0% over the same period for the summer and winter, respectively.

Dominion Energy Virginia is also part of the Eastern Interconnection transmission grid, meaning its transmission system is interconnected, directly or indirectly, with all of the other transmission systems in the United States and Canada between the Rocky Mountains and the Atlantic Coast, except for Quebec and most of Texas. All of the transmission systems in the Eastern Interconnection are dependent on each other for moving bulk power through the transmission system and for

reliability support. Dominion Energy Virginia’s service to its customers is extremely reliant on a robust and reliable regional transmission system.

North American Electric Reliability Corporation (“NERC”) has been designated by the Federal Energy Regulatory Commission (“FERC”) as the electric reliability organization for the United States. Accordingly, NERC requires that the planning authority and transmission planner develop planning criteria to ensure compliance with NERC Reliability Standards. Mandatory NERC Reliability Standards require that a transmission owner (“TO”) develop facility interconnection requirements that identify load and generation interconnection minimum requirements for a TO’s transmission system, as well as the TO’s reliability criteria.<sup>3</sup>

Federally mandated NERC Reliability Standards constitute minimum criteria with which all public utilities must comply as components of the interstate electric transmission system. Moreover, the Energy Policy Act of 2005 mandates that electric utilities follow these NERC Reliability Standards and imposes fines on utilities found to be in noncompliance up to \$1.3 million per day per violation.

PJM’s Regional Transmission Expansion Plan (“RTEP”) is the culmination of a FERC-approved annual transmission planning process that includes extensive analysis of the electric transmission system to determine any needed improvements.<sup>4</sup> PJM’s annual RTEP is based on the effective criteria in place at the time of the analyses, including applicable standards and criteria of NERC, PJM, and local reliability planning criteria, among others.<sup>5</sup> Projects identified through the RTEP process are developed by the TO in coordination with PJM, and are presented at the Transmission Expansion Advisory Committee (“TEAC”) meetings prior to inclusion in the RTEP that is then presented for approval by the PJM Board of Managers (the “PJM Board”).

Outcomes of the RTEP process include three types of transmission system upgrades or projects: (i) baseline upgrades are those that resolve a system reliability criteria violation, which can include planning criteria from NERC, ReliabilityFirst, SERC Reliability Corporation, PJM, and TOs; (ii) network upgrades are new or upgraded facilities required primarily to eliminate reliability criteria violations caused by proposed generation, merchant transmission, or long-term firm transmission service requests; and (iii) supplemental projects are projects initiated by the TO in order to interconnect new customer load, address degraded equipment performance, improve operational flexibility and efficiency, and increase infrastructure resilience. While supplemental projects are included in the RTEP, and the PJM Board administers stakeholder review of supplemental

---

<sup>3</sup> See FAC-001-3 (R1, R3) (effective April 1, 2021), which can be found at <https://cdn-dominionenergy-prd-001.azureedge.net/-/media/pdfs/virginia/parallel-generation/facility-interconnection-requirements-signed.pdf?la=en&rev=38f51ffb04b1489f921b32a41d9887c8>.

<sup>4</sup> PJM Manual 14B (effective July 1, 2021) focuses on the RTEP process and can be found at <https://www.pjm.com/-/media/documents/manuals/m14b.ashx>.

<sup>5</sup> See PJM Manual 14B, Attachment D: PJM Reliability Planning Criteria. *See supra*, n. 4.

projects as part of the RTEP process, the PJM Board does not actually approve such projects. See Section I.J for a discussion of the PJM process as it relates to this Rebuild Project.

As supported by Section I.J and discussed below, this Rebuild Project is necessary to replacing aging concrete pole infrastructure that is at the end of its service life along an approximately 1.17-mile segment of 230 kV Line #2019, as well as the entire approximately 3.37-mile 230 kV Line #2007 in the City of Virginia Beach. See Attachment I.A.1 for an overview map of the proposed Rebuild Project.

Line #2019 runs for a total of approximately 2.34 miles between the Company's existing Greenwich and Thalia Substations. Line #2007 runs for approximately 3.37 miles between the Company's existing Thalia and Lynnhaven Substations.

The approximately 1.17-mile segment of Line #2019 between the Company's existing Greenwich Substation and Structure #2019/20 was built in 1988 on double circuit structures, which also support Green Run-Greenwich Line #245. This segment of line is comprised of a mixture of steel and concrete monopoles, all of which are in good condition. Accordingly, the structures and conductor along this segment of the line are not being replaced as part of the Rebuild Project.<sup>6</sup>

The 1.17-mile section of Line #2019 between Structure #2019/20 and the Thalia Substation, as well as the entire 3.37 miles of Line #2007, were built in 1970 and primarily are comprised of single circuit concrete monopoles. The Rebuild Project would rebuild all existing structures from Structure #2019/21 to Structure #2007/102 outside of the Lynnhaven Substation, the majority of which are concrete poles. These concrete poles have been identified through field inspections to be showing significant deterioration.

Deterioration of the concrete poles is identified as damage consisting of the following: widespread cracking of greater than 1/8 inch, spalling of the concrete surface, visible steel reinforcing, rust staining, and extensive efflorescence. These instances of deterioration impact the health of the concrete pole structures as follows:

- The open cracks and spalling of the concrete surface allow for the infiltration of moisture and contaminants that can accelerate the deterioration of the concrete and its steel reinforcement.
- When steel reinforcement is visible, it is inherently exposed to environmental conditions that can cause deterioration and weaken the overall strength of the structure. Similarly, rust staining can be indicative of advanced steel deterioration.

---

<sup>6</sup> The Company is proposing to replace the shield wires along this segment of Line #2019 between the existing Greenwich Substation and Structure #2019/20. See *supra*, n. 2.

- Efflorescence can have multiple causes, but at their root they are all generally traced back to moisture infiltration that draws salts embedded in the concrete to the surface. Severe cases of efflorescence can result in the breakdown of the concrete, weakening the structure and accelerating further deterioration of the concrete and steel reinforcement.

Section C.2.9 of the Company’s Planning Criteria addresses electric transmission infrastructure approaching its end of life:<sup>7</sup>

Electric transmission infrastructure reaches its end of life as a result of many factors. Some factors such as extreme weather and environmental conditions can *shorten* infrastructure life, while others such as maintenance activities can *lengthen* its life. Once end of life is recognized, in order to ensure continued reliability of the transmission grid, a decision must be made regarding the best way to address this end-of-life asset.

For this criterion, “end of life” is defined as the point at which infrastructure is at risk of failure, and continued maintenance and/or refurbishment of the infrastructure is no longer a valid option to extend the life of the facilities consistent with Good Utility Practice and Dominion Energy Transmission Planning Criteria. The infrastructure to be evaluated under this end-of-life criterion are all regional transmission lines operated at 500 kV and above.

The decision point of this criterion is based on satisfying two metrics:

- 1) *Facility is nearing, or has already passed, its end of life, and*
- 2) *Continued operation risks negatively impacting reliability of the transmission system.*

For facilities that satisfy both of these metrics, this criterion mandates either replacing these facilities with in-kind infrastructure that meets current Dominion standards or employing an alternative solution to ensure the Dominion transmission system satisfies all applicable reliability criteria.

The Rebuild Project will rebuild 1.17 miles of Line #2019 and the entire 3.37-mile Line #2007, which have been identified for rebuild based on Dominion Energy Virginia’s assessment in accordance with the Company’s Planning Criteria and

---

<sup>7</sup> See *supra*, n. 1. The Company’s Planning Criteria regarding infrastructure to be evaluated under end-of-life (“EOL”) criteria was updated effective March 24, 2020. However, the process for determining that an asset has reached its EOL remains the same; therefore, the Company continues to use the criteria evaluation process outlined in Section C.2.9 of the Planning Criteria. See: <http://www.pjm.com/-/media/committees-groups/committees/srrteps/2020/20200616/20200616-dominion-local-planning-assumptions-2020.ashx>.

consistent with sound engineering judgment.

*1) Facility is nearing, or has already passed, its end of life*

In regard to the first metric of the Company's Planning Criteria addressing end of life, the concrete structures supporting the 1.17-mile segment of Line #2019 proposed to be rebuilt are experiencing hairline cracking at a minimum, and many of the poles have more advanced cracking that has exposed some of the interior reinforcing bars and cables. Out of the 20 concrete pole structures supporting this portion of Line #2019, six poles are currently in poor condition in need of replacement in the near term, and four poles are in fair condition, progressing to poor condition. The remaining ten poles have hairline cracking and other damage. Based on the concrete pole assessment, this portion of Line #2019 has been labeled as "Deteriorating condition" and a complete rebuild is recommended because the condition and age of these structures indicates that they have reached the end of their life.

The concrete structures supporting Line #2007 are experiencing the same pattern of deterioration. The cracks allow for significant water infiltration, which can accelerate the deterioration of the concrete and cause rusting of the steel reinforcing components. Out of the 60 concrete pole structures supporting Line #2007, five poles are currently in poor condition in need of replacement in the near term, and 40 poles are in fair condition, progressing to poor condition. The remaining 15 poles have hairline cracking and other damage. Based on the concrete pole assessment, Line #2007 has been labeled as "Deteriorating condition" and a complete rebuild is recommended because the condition and age of these structures indicates that they have reached the end of their life.

In addition to the concrete structures, industry guidelines indicate equipment life for conductor and connectors are 40-60 years, and porcelain insulators are 50 years. The combination of deteriorating condition and age indicate that these structures and line equipment have reached their end of life.

*2) Continued operation risks negatively impacting reliability of the transmission system*

Regarding the second metric of the Company's Planning Criteria addressing end of life, Line #2019 and Line #2007 each provide service to Dominion Energy Virginia's Thalia Substation, which in turn serves approximately 30,553 direct-connect customers in the City of Virginia Beach, Virginia. The Company would be unable to continue to provide reliable transmission service to these customers unless it addresses the aging infrastructure at the end of its service life.

The Company relied on one of the four reliability tests identified in the Company's

Planning Criteria. The relevant section of the Planning Criteria states in part:<sup>8</sup>

2. *Reliability and System Impact*

The reliability impact of continued operation of a facility will be determined based on a planning assessment and operational performance considerations. The end-of-life determination for a facility to be tested for reliability impact will be assessed by evaluating the impact on short- and long-term reliability with and without the facility in service. The existing system with the facility removed will become the base case system for which all reliability tests will be performed.

The primary four (4) reliability tests to be considered are:

1. NERC Reliability Standards
2. PJM Planning Criteria – As documented in PJM Manual 14B PJM Region Transmission Planning Process
3. Dominion Transmission Planning Criteria contained in this document
4. Operational Performance – This test will be based on input from PJM and/or Dominion System Operations as to the impact on reliably operating the system without the facility

Additional factors to be evaluated under system impact may include but not be limited to:

1. Market efficiency
2. Stage 1A Auction Revenue Rights (ARR) sufficiency
3. Public policy
4. SERC Reliability Criteria

Failure of any of these reliability tests, along with the end-of-life assessment discussed herein, will indicate a violation of the end-of-life criteria, and necessitate replacement as mandated earlier in this document.

First, the Company relied on Dominion Energy Virginia's Planning Criteria. Both Lines #2019 and #2007 serve the 134 MW of load at Thalia Substation. One of these lines is needed to serve the entire load at Thalia Substation. Removing the other line would result in a radial transmission line exceeding 100 MW of tapped load. This would violate the Company's Planning Criteria C.2.6 regarding radial transmission lines stating that "loading on single source radial transmission lines will be limited to 100 MW."

---

<sup>8</sup> See *supra*, n. 1.

Second, the Company relied on the fourth reliability test identified in the Company's Planning Criteria—Operational Performance—which states in part that the “test will be based on input from PJM and/or Dominion Energy System Operations as to the impact on reliably operating the system without the facility.” Existing Lines #2019 and #2007 are integral components to maintaining the network of Company's 230 kV system. Retiring either line could cause serious reliability issues since these lines are part of critical support of power flow to the east. The Rebuild Project is necessary to keep these lines in service for system reliability reasons so that reliable transmission service will not be compromised.

The Company submitted the Rebuild Project proposal as a supplemental project to the PJM RTEP process in October 2020 and November 2020 to address the end-of-life criteria. No additional reliability studies were required by PJM in support of the need for the proposed Rebuild Project because service to customers fed from Dominion Energy Virginia's Thalia Substation would be dropped absent the Rebuild Project. See Section I.J.

\*\*\*

In summary, the proposed Rebuild Project will replace aging infrastructure at the end of its service life in compliance with the Company's mandatory Planning Criteria and consistent with sound engineering judgment, thereby enabling the Company to maintain the overall long-term reliability of its transmission system, as well as to provide important system reliability benefits to the Company's entire network.

ATTACHMENT I.A.1

**PROJECT OVERVIEW MAP**

Lines #2019 and #2007 Rebuild Project

City of Virginia Beach, Virginia

Owner/Applicant:  
Dominion Energy Virginia

C2 Env Project:  
0233

Prepared By:  
GCF

Date:  
07/19/22

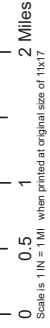

**LEGEND**

- Existing Line #2019 Project Centerline
- Existing Line #2007 Project Centerline
- Existing Structure 2019/20
- Existing Substation
- US or VA Primary Highway
- Local or Main Road
- Railroad
- County Boundary
- NHD Stream/River
- NHD Waterbody

Notes:  
1. Basemap from ESRI Topographic Map  
2. Substations from Dominion Energy  
3. Roads and railroads from VGIN  
4. Streams, rivers and waterbodies from USGS National Hydrography Data



SHEET 1 OF 1

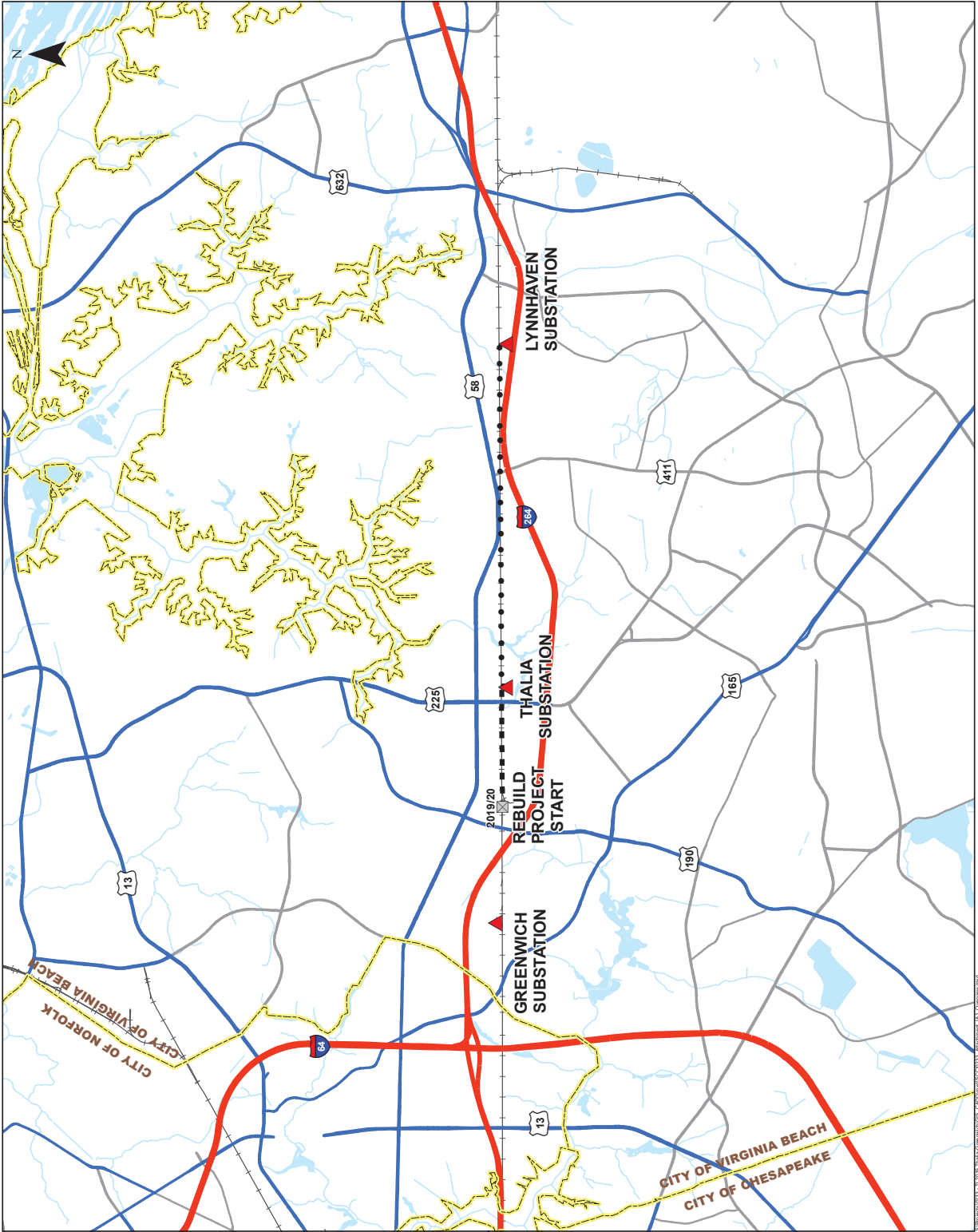

**I. NECESSITY FOR THE PROPOSED PROJECT**

**B. Detail the engineering justifications for the proposed project (for example, provide narrative to support whether the proposed project is necessary to upgrade or replace an existing facility, to significantly increase system reliability, to connect a new generating station to the Applicant’s system, etc.). Describe any known future project(s), including but not limited to generation, transmission, delivery point or retail customer projects, that require the proposed project to be constructed. Verify that the planning studies used to justify the need for the proposed project considered all other generation and transmission facilities impacting the affected load area, including generation and transmission facilities that have not yet been placed into service. Provide a list of those facilities that are not yet in service.**

Response: **(1) Engineering Justification for Project**

See Section I.A of the Appendix.

**(2) Known Future Projects**

There are no known future projects that require the Rebuild Project to be constructed. The Rebuild Project is required by the Company’s end-of-life criteria, as described in Section I.A of the Appendix.

**(3) Planning Studies**

Not applicable.

**(4) Facilities List**

Not applicable.

## I. NECESSITY FOR THE PROPOSED PROJECT

- C. Describe the present system and detail how the proposed project will effectively satisfy present and projected future electrical load demand requirements. Provide pertinent load growth data (at least five years of historical summer and winter peak demands and ten years of projected summer and winter peak loads where applicable). Provide all assumptions inherent within the projected data and describe why the existing system cannot adequately serve the needs of the Applicant (if that is the case). Indicate the date by which the existing system is projected to be inadequate.

Response: Attachment I.G.1 shows the portion of the Company's transmission system in the area of the proposed Rebuild Project. The existing Line #2019 and Line #2007 are both part of the Company's 230 kV network, which supports the delivery of generation to retail and wholesale customers. These lines support the network in the eastern Virginia area.

The table in Attachment I.C.1 provides 10 years of historical system peak loads for the Company's Virginia Beach Load Area, which includes Line #2019 and Line #2007. The table in Attachment I.C.1 also provides the anticipated summer and winter peak loads from 2022 to 2031 for this area. The projected loads in Attachment I.C.1 represent the Company's forecasted peaks based on actual load and the PJM 2022 Load Forecast and demonstrate stable load demand in the area. Over the period from 2022 to 2031, the summer peak electrical demand for this area is projected to vary between 2,625 MW and 2,810 MW, and the winter peak electrical demand for this area is projected to vary between 2,318 MW and 2,525 MW.

The existing Line #2019 and Line #2007 cannot adequately serve the needs of the Company and its customers because of aging infrastructure, as discussed in Section I.A. The Company has created a plan to address its end-of-life facilities, setting target completion dates for end-of-life projects based on the condition of the facilities, the Company's resources, and the need to schedule outages. The desired in-service date for completion of the proposed Rebuild Project is December 31, 2025.

Completing the Rebuild Project will support Dominion Energy Virginia's continued reliable electric service to retail and wholesale customers and will support the future overall growth and system generation capability in the area.

**Historical load (MW)**

	<b>2012</b>	<b>2013</b>	<b>2014</b>	<b>2015</b>	<b>2016</b>	<b>2017</b>	<b>2018</b>	<b>2019</b>	<b>2020</b>	<b>2021</b>
<b>Virginia Beach - Summer</b>	2576	2533	2537	2648	2656	2643	2544	2566	2597	2548
<b>Virginia Beach - Winter</b>	2265	2201	2374	2853	2494	2268	2572	2266	2041	2157

**Projected load (MW)\***

	<b>2022</b>	<b>2023</b>	<b>2024</b>	<b>2025</b>	<b>2026</b>	<b>2027</b>	<b>2028</b>	<b>2029</b>	<b>2030</b>	<b>2031</b>
<b>Virginia Beach - Summer</b>	2619	2625	2637	2654	2655	2664	2682	2695	2709	2810
<b>Virginia Beach - Winter</b>	2498	2544	2565	2590	2566	2573	2581	2583	2588	2525

\*Forecasted values are based on the PJM 2022 Load Forecast

**I. NECESSITY FOR THE PROPOSED PROJECT**

- D. If power flow modeling indicates that the existing system is, or will at some future time be, inadequate under certain contingency situations, provide a list of all these contingencies and the associated violations. Describe the critical contingencies including the affected elements and the year and season when the violation(s) is first noted in the planning studies. Provide the applicable computer screenshots of single-line diagrams from power flow simulations depicting the circuits and substations experiencing thermal overloads and voltage violations during the critical contingencies described above.**

Response: Not applicable.

## I. NECESSITY FOR THE PROPOSED PROJECT

### E. Describe the feasible project alternatives, if any, considered for meeting the identified need including any associated studies conducted by the Applicant or analysis provided to the RTO. Explain why each alternative was rejected.

Response: No feasible alternatives have been submitted to PJM. As stated in Section I.A, not rebuilding 4.54 miles of 230 kV transmission lines between the Greenwich and Lynnhaven Substations results in not serving approximately 30,553 direct-connect customers in the City of Virginia Beach, Virginia.

Pursuant to the Commission's November 26, 2013, Order entered in Case No. PUE-2012-00029, and its November 1, 2018, Final Order entered in Case No. PUR-2018-00075 ("2018 Final Order"), the Company is required to provide analysis of demand-side resources ("DSM") incorporated into the Company's planning studies. DSM is the broad term that includes both energy efficiency ("EE") and demand response ("DR"). In this case, the Company has identified a need for the Rebuild Project based on the need to replace aging infrastructure at the end of its service life in order to comply with the Company's mandatory Planning Criteria and consistent with sound engineering judgment, thereby enabling the Company to maintain the overall long-term reliability of its transmission system.<sup>9</sup> Notwithstanding, when performing an analysis based on PJM's 50/50 load forecast, there is no adjustment in load for DR programs that are considered in PJM's fixed resource requirement plan ("FRR") because PJM only dispatches DR when the system is under stress (*i.e.*, a system emergency). Accordingly, while existing DSM is considered to the extent the load forecast accounts for it, DR that has been bid previously into PJM's reliability pricing model ("RPM") market is not a factor in this particular Application because of the identified need for the Rebuild Project. Based on these considerations, the evaluation of the Rebuild Project demonstrated that despite accounting for DSM consistent with PJM's methods, the Rebuild Project is necessary.

Incremental DSM also will not absolve the need for the Rebuild Project. As reflected in Attachment I.C.1, the peak load area for this Rebuild Project (historic and projected) ranges from 2,041 to 2,853 MW (summer and winter). By way of comparison, statewide, the Company achieved demand savings of 308.4 MW (net) / 396.8 MW (gross) from its DSM Programs in 2021.

---

<sup>9</sup> While the PJM load forecast does not directly incorporate DR, its load forecast incorporates variables derived from Itron that reflect EE by modeling the stock of end-use equipment and its usages. Further, because PJM's load forecast considers the historical non-coincident peak ("NCP") for each load serving entity ("LSE") within PJM, it reflects the actual load reductions achieved by DSM programs to the extent an LSE has used DSM to reduce its NCPs.

## I. NECESSITY FOR THE PROPOSED PROJECT

### F. Describe any lines or facilities that will be removed, replaced, or taken out of service upon completion of the proposed project, including the number of circuits and normal and emergency ratings of the facilities.

Response: The Rebuild Project includes the removal and replacement of existing facilities on existing Lines #2019 and #2007, as described below. There will be no lines permanently taken out of service as part of the proposed Rebuild Project.

The existing capacity of the 1.17-mile segment of Line #2019 between Structure #2019/20 and the Thalia Substation has normal/emergency ratings of 788/788 MVA<sup>10</sup> summer and 916/924 MVA winter. With the Rebuild Project, the capacity of the new conductor within this 1.17-mile segment will have normal/emergency ratings of 1,573/1,573 MVA summer and 1,648/1,648 MVA winter.

The existing capacity of Line #2007 between the Thalia and Lynnhaven Substations has normal/emergency ratings of 788/788 MVA summer and 916/924 MVA winter. With the Rebuild Project, the capacity of the rebuilt line will have normal/emergency ratings of 1,573/1,573 MVA summer and 1,648/1,648 MVA winter.

See also Section II.C as to substation-related work.

#### **Line #2019 – Structure #2019/20 to the Thalia Substation (Structure #2019/42)**

For the 1.17-mile segment of Line #2019 being rebuilt, twenty 230 kV concrete monopoles and one 230 kV painted steel monopole will be replaced by twenty-one 230 kV galvanized steel monopoles. All proposed structures will be installed on new concrete foundations. The existing suspension structures with I-string insulator assemblies are being replaced with V-string insulator assemblies on the proposed structures due to right-of-way constraints.

In addition to the structure replacements, the existing 3-phase single 2500 ACAR conductors on Line #2019 will be replaced with 3-phase twin-bundled 768.2 ACSS/TW/HS conductors. The single 3#6 alumoweld shield wire will be replaced with two fiber optic shield wires.

The existing galvanized steel A-frame backbone Structure #2019/42 inside of Thalia Substation will remain.

---

<sup>10</sup> Apparent power, measured in megavolt amperes (“MVA”), is made up of real power (megawatt or “MW”) and reactive power megavolt ampere reactive (“MVAR”). The power factor (“pf”) is the ratio of real power to apparent power. For loads with a high pf (approaching unity), real power will approach apparent power and the two can be used interchangeably. Load loss criteria specify real power (MW) units because that represents the real power that will be dropped; however, MVA is used to describe the equipment ratings to handle the apparent power, which includes the real and reactive load components.

### **Thalia Substation – New Static Poles**

A total of four new 75-foot galvanized steel static poles will be installed within the existing substation footprint to facilitate the connection of four fiber optic shield wires to the Thalia Substation control house. Two fiber optic shield wires are associated with Line #2019 and two are associated with Line #2007. Additionally, two existing spans of 3#6 alumoweld static wire will be replaced by two spans of 7#7 alumoweld static wire to provide improved lightning protection for the substation.

### **Line #2007 – Thalia Substation (Structure #2007/41) to Lynnhaven Substation (Structure #2007/104)**

For the 3.37-mile segment of Line #2007 being rebuilt, sixty 230 kV concrete monopoles and one 230 kV painted steel monopole will be replaced by sixty-one 230 kV galvanized steel monopoles. One new 75-foot galvanized steel static pole will be installed outside of Lynnhaven Substation on Company-owned property. All proposed structures will be installed on new concrete foundations. The existing suspension structures with I-string insulator assemblies are being replaced with V-string insulator assemblies on the proposed structures due to right-of-way constraints.

In addition to the structure replacements, the existing 3-phase single 2500 ACAR conductors on Line #2007 will be replaced with 3-phase twin-bundled 768.2 ACSS/TW/HS conductors. The single 3#6 alumoweld shield wire will be replaced with two fiber optic shield wires.

The existing structures to remain include galvanized steel A-frame backbone Structure #2007/41 inside the Thalia Substation, double circuit painted steel Structure #2007/103 (#2072/1) outside of the Lynnhaven Substation, and concrete backbone Structure #2007/104 (#2025/90) inside the Lynnhaven Substation.

**I. NECESSITY FOR THE PROPOSED PROJECT**

- G. Provide a system map, in color and of suitable scale, showing the location and voltage of the Applicant's transmission lines, substations, generating facilities, etc., that would affect or be affected by the new transmission line and are relevant to the necessity for the proposed line. Clearly label on this map all points referenced in the necessity statement.**

Response: See Attachment I.G.1.

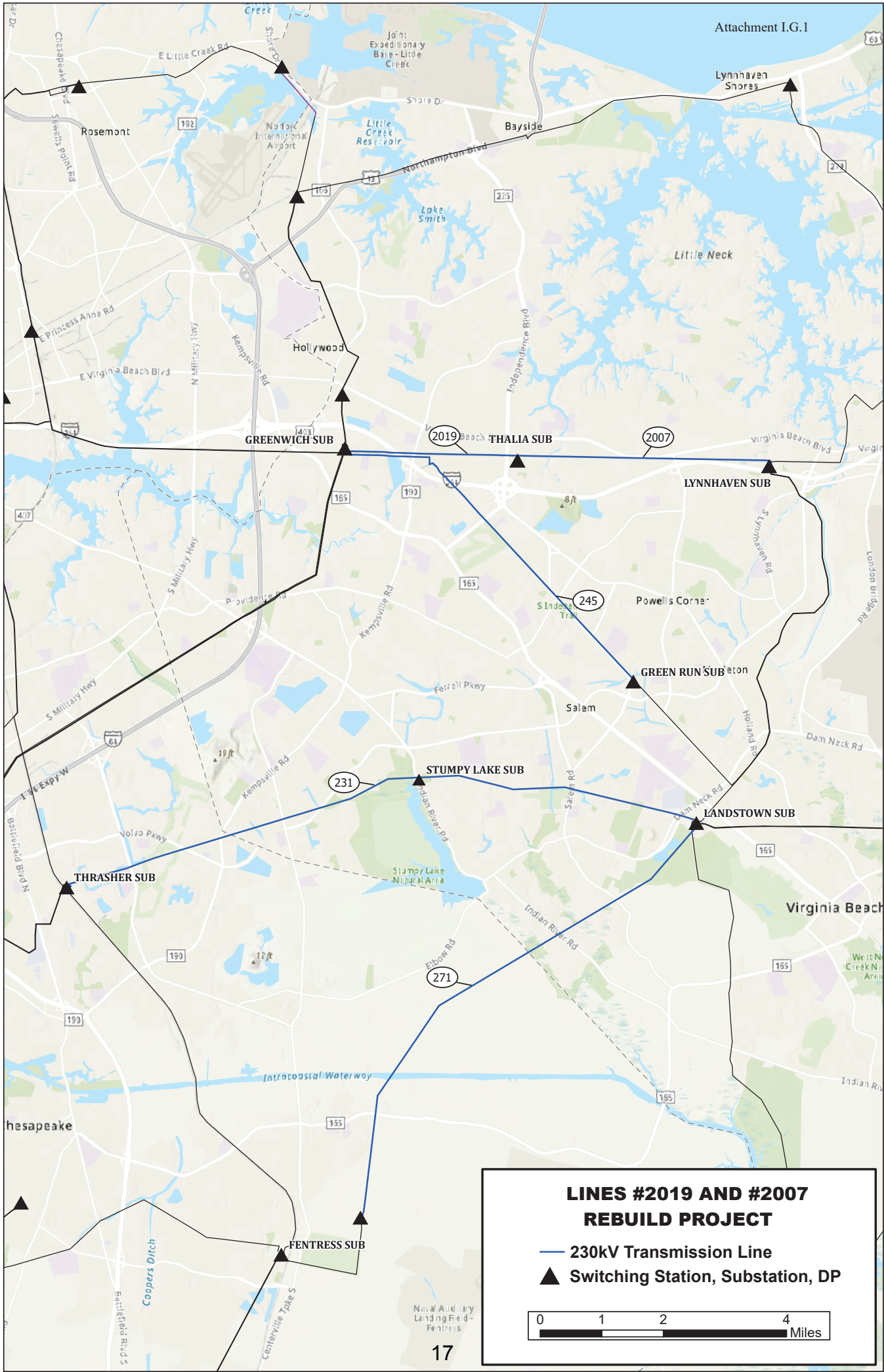

Attachment I.G.1

**LINES #2019 AND #2007  
REBUILD PROJECT**

- 230kV Transmission Line
- ▲ Switching Station, Substation, DP

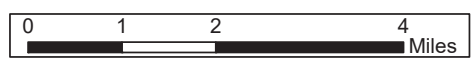

**I. NECESSITY FOR THE PROPOSED PROJECT**

**H. Provide the desired in-service date of the proposed project and the estimated construction time.**

Response: The desired in-service date for the Rebuild Project is December 31, 2025.

The Company estimates it will take approximately 28 months for detailed engineering, materials procurement, permitting, and construction after a final order from the Commission. Accordingly, to support this estimated pre-construction activity timeline and construction plan, the Company respectfully requests a final order by September 1, 2023. Should the Commission issue a final order by September 1, 2023, the Company estimates that construction should begin in July 2024 and be completed in December 2025. This construction timeline will enable the Company to meet the targeted in-service date for the Rebuild Project. This schedule is contingent upon obtaining the necessary permits and outages. Dates may need to be adjusted based on permitting delays or design modifications to comply with additional agency requirements identified during the permitting application process, as well as the ability to schedule outages or unpredictable delays due to labor shortages and/or materials/supply issues based on other extensive project work ongoing in the vicinity of the Rebuild Project.

**I. NECESSITY FOR THE PROPOSED PROJECT**

- I. Provide the estimated total cost of the project as well as total transmission-related costs and total substation-related costs. Provide the total estimated cost for each feasible alternative considered. Identify and describe the cost classification (e.g. “conceptual cost,” “detailed cost,” etc.) for each cost provided.**

Response: The total estimated conceptual cost of the Rebuild Project is approximately \$91.1 million, which includes approximately \$87.4 million for transmission-related work, and approximately \$3.7 million for substation-related work (2022 dollars).

**I. NECESSITY FOR THE PROPOSED PROJECT**

- J. If the proposed project has been approved by the RTO, provide the line number, regional transmission expansion plan number, cost responsibility assignments, and cost allocation methodology. State whether the proposed project is considered to be a baseline or supplemental project.**

Response: The Company submitted the Rebuild Project proposal as a supplemental project to the PJM RTEP process in October 2020 and November 2020 to address the end-of-life criteria. Attachment I.J.1 contains the relevant slides presented at the October 2020 PJM TEAC meeting, and Attachment I.J.2 contains the relevant slides that the Company prepared for presentation at the November 2020 PJM TEAC meeting. The Company presented revised slides to PJM on July 12, 2022, as to the Rebuild Project cost updates that are reflected in this Appendix. As these are supplemental projects, the Company anticipates that these revisions will have no impact. See Attachment I.J.3. No additional reliability studies were required by PJM in support of the need for the proposed Rebuild Project because service to customers fed from Dominion Energy Virginia's Thalia Substation would be dropped absent the Rebuild Project. The proposed Rebuild Project was incorporated into PJM's RTEP process as supplemental projects (s2499 and s2500).

The Rebuild Project is presently 100% cost allocated to the DOM Zone.

# Dominion Supplemental Projects

Transmission Expansion Advisory  
Committee  
October 6, 2020



## Needs

Stakeholders must submit any comments within 10 days of this meeting in order to provide time necessary to consider these comments prior to the next phase of the M-3 process

# Dominion Transmission Zone: Supplemental Equipment Material Condition, Performance and Risk

**Need Number:** DOM-2020-0036

**Process Stage:** Need Meeting 10/06/2020

**Project Driver:** Equipment Material Condition, Performance and Risk

**Specific Assumption References:**

See details on Equipment Material Condition, Performance and Risk in Dominion’s Planning Assumptions presented in December 2019 and updated in June 2020.

**Problem Statement:**

Dominion Energy has identified a need to replace 60 concrete structures of 230kV Line #2007 (Lynnhaven – Thalia) based on the Company’s End of Life criteria.

- The 3.37 miles long line was constructed on concrete structures in 1970. These structures have developed significant structural concerns as they age.
- Every pole is experiencing hairline cracking at a minimum, and many of the poles have more advanced cracking that has exposed some of the interior reinforcing bars and cables.
- The cracks allow for significant water infiltration which can accelerate the deterioration of the concrete and cause rusting of the steel reinforcing components.
- The 230kV Line #2007 provides service to Thalia substation with approximately 134 MW of tapped load.

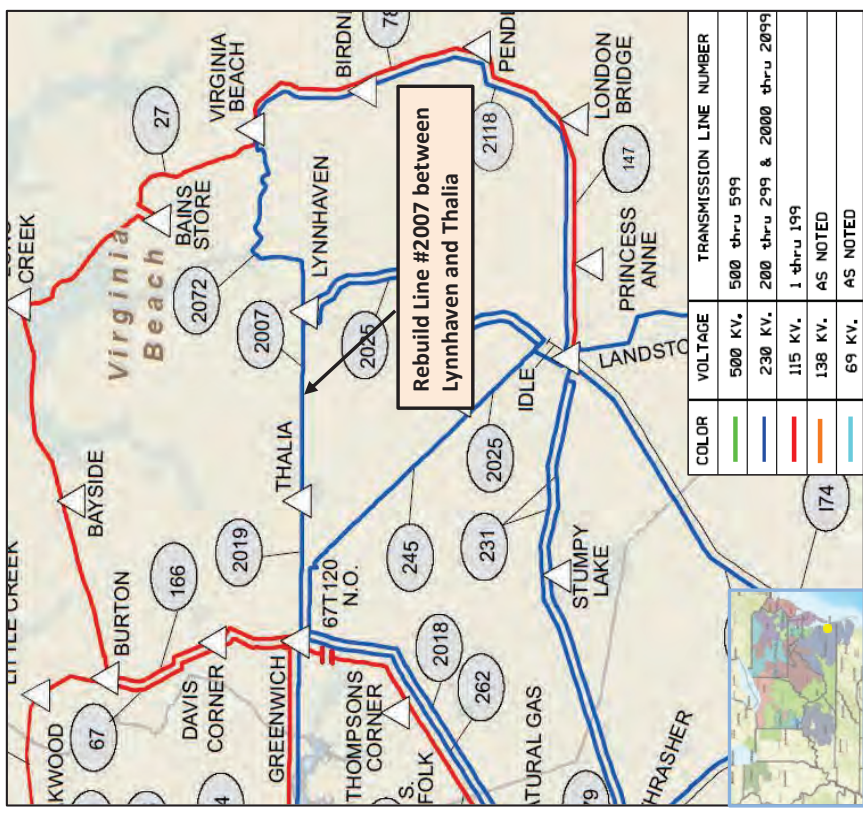

# Dominion Transmission Zone: Supplemental Equipment Material Condition, Performance and Risk

**Need Number:** DOM-2020-0037

**Process Stage:** Need Meeting 10/06/2020

**Project Driver:** Equipment Material Condition, Performance and Risk

**Specific Assumption References:**

See details on Equipment Material Condition, Performance and Risk in Dominion's Planning Assumptions presented in December 2019 and updated in June 2020.

**Problem Statement:**

- Dominion Energy has identified a need to replace 20 concrete structures (Structure #2019/21 – Thalia segment) of 230kV Line #2019 (Greenwich – Thalia) based on the Company's End of Life criteria.
- The 1.17 miles segment of 230kV Line #2019 was constructed on concrete structures in 1970. These structures have developed significant structural concerns as they age.
  - Every pole is experiencing hairline cracking at a minimum, and many of the poles have more advanced cracking that has exposed some of the interior reinforcing bars and cables.
  - The cracks allow for significant water infiltration which can accelerate the deterioration of the concrete and cause rusting of the steel reinforcing components.
  - The 230kV Line #2019 provides service to Thalia substation with approximately 134 MW of tapped load.

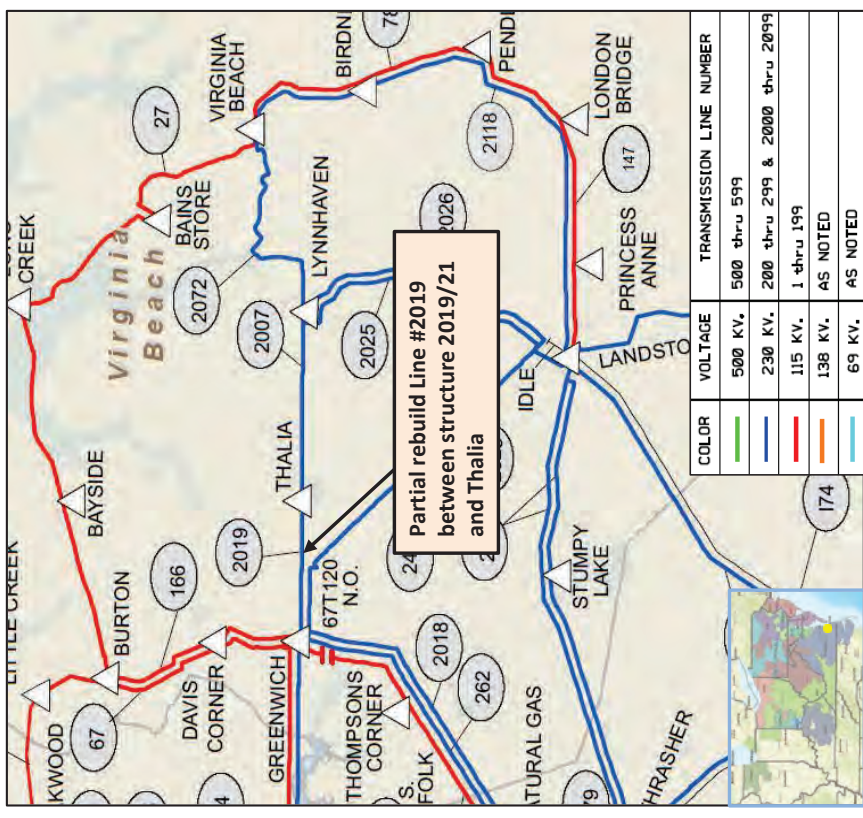

## Revision History

09/25/2020 – V1 – Original version posted to pjim.com.

10/01/2020 – V2 – Removed slides 11 & 12 and adjusted ordering of slides.

Corrected a spelling error on slide 11 and updated substation name on slide 12.

# Dominion Supplemental Projects

Transmission Expansion Advisory  
Committee  
November 4, 2020

## Solutions

Stakeholders must submit any comments within 10 days of this meeting in order to provide time necessary to consider these comments prior to the next phase of the M-3 process

# Dominion Transmission Zone: Supplemental Equipment Material Condition, Performance and Risk

**Need Number:** DOM-2020-0036

**Process Stage:** Solutions Meeting 11/04/2020

**Previously Presented:** Need Meeting 10/06/2020

**Project Driver:** Equipment Material Condition, Performance and Risk

**Specific Assumption References:**

See details on Equipment Material Condition, Performance and Risk in Dominion’s Planning Assumptions presented in December 2019 and updated in June 2020.

**Problem Statement:**

- Dominion Energy has identified a need to replace 60 concrete structures of Line #2007 (Lynnhaven – Thalia) based on the Company’s End of Life criteria.
- The 3.37 miles long line was constructed on concrete structures in 1970. These structures have developed significant structural concerns as they age.
  - Every pole is experiencing hairline cracking at a minimum, and many of the poles have more advanced cracking that has exposed some of the interior reinforcing bars and cables.
  - The cracks allow for significant water infiltration which can accelerate the deterioration of the concrete and cause rusting of the steel reinforcing components.
  - The Line #2007 provides service to Thalia substation with approximately 134 MW of tapped load.

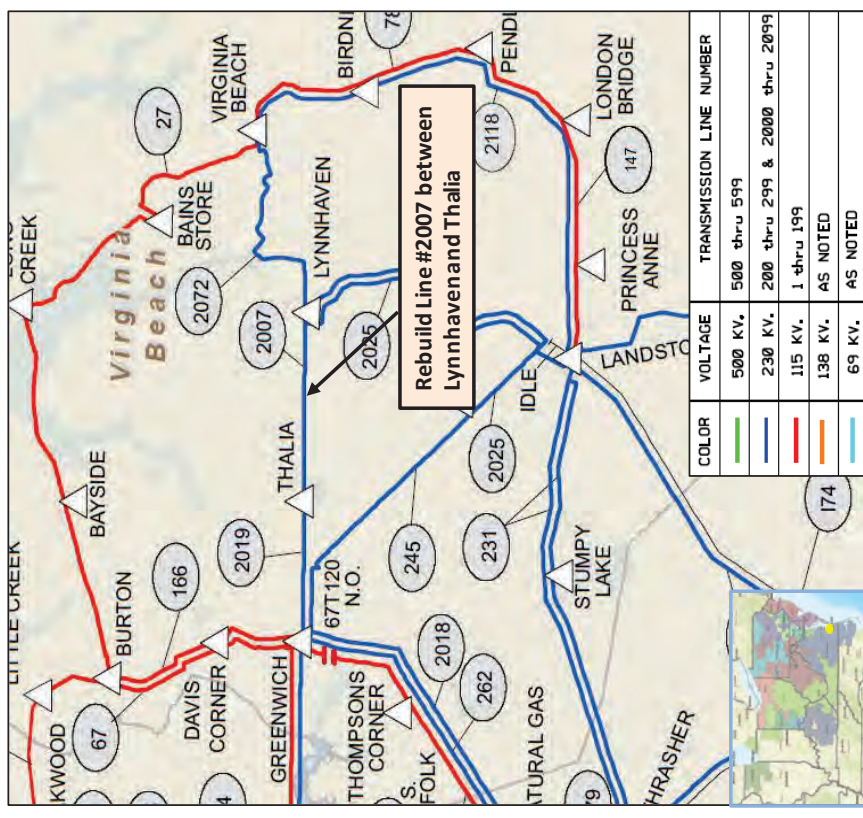

# Dominion Transmission Zone: Supplemental Line #2007 End-of-Life Rebuild – Lynnhaven to Thalia

**Need Number:** DOM-2020-0036

**Process Stage:** Solutions Meeting 11/04/2020

**Proposed Solution:**

Rebuild the 3.37 miles long Line #2007 between Lynnhaven and Thalia to current 230kV standards. The normal summer rating of the line will be 1047 MVA.

**Estimated Project Cost:** \$7.0 M

**Alternatives Considered:**

No feasible alternatives

**Project Target In-service Date:** 12/31/2025

**Project Status:** Conceptual

**Model:**



# Dominion Transmission Zone: Supplemental Equipment Material Condition, Performance and Risk

**Need Number:** DOM-2020-0037

**Process Stage:** Solutions Meeting 11/04/2020

**Previously Presented:** Need Meeting 10/06/2020

**Project Driver:** Equipment Material Condition, Performance and Risk

**Specific Assumption References:**

See details on Equipment Material Condition, Performance and Risk in Dominion’s Planning Assumptions presented in December 2019 and updated in June 2020.

**Problem Statement:**

- Dominion Energy has identified a need to replace 20 concrete structures (Structure 2019/21 – Thalia segment) of Line #2019 (Greenwich – Thalia) based on the Company’s End of Life criteria.
- The 1.17 miles segment of Line #2019 was constructed on concrete structures in 1970. These structures have developed significant structural concerns as they age.
- Every pole is experiencing hairline cracking at a minimum, and many of the poles have more advanced cracking that has exposed some of the interior reinforcing bars and cables.
- The cracks allow for significant water infiltration which can accelerate the deterioration of the concrete and cause rusting of the steel reinforcing components.
- The Line #2019 provides service to Thalia substation with approximately 134 MW of tapped load.

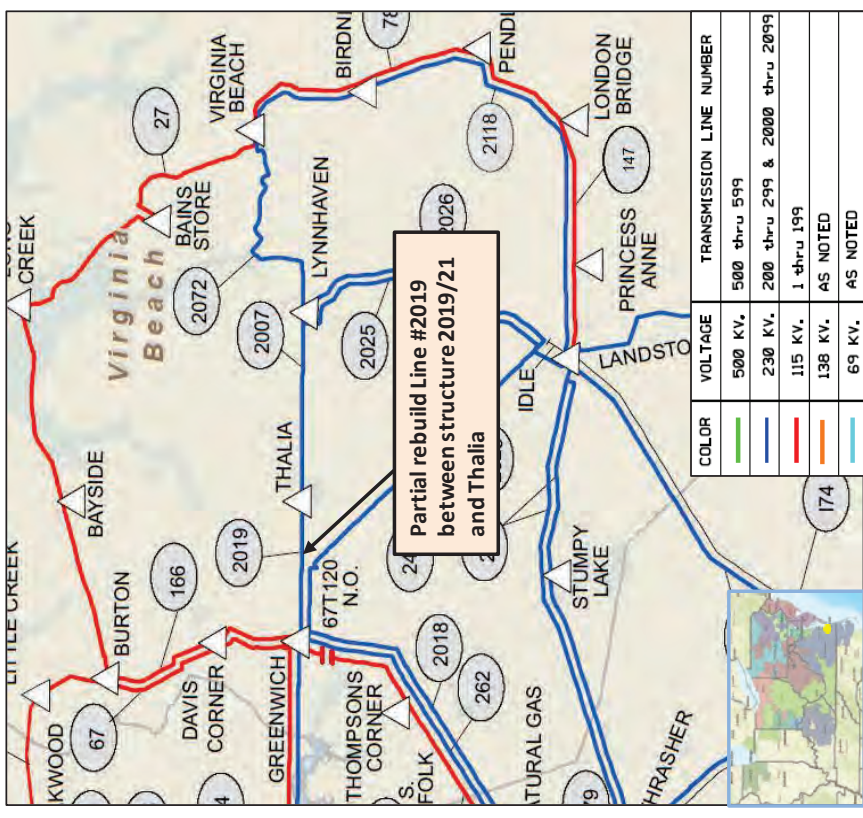

# Dominion Transmission Zone: Supplemental Line #2019 End-of-Life Partial Rebuild – Thalia to Greenwich

**Need Number:** DOM-2020-0037

**Process Stage:** Solutions Meeting 11/04/2020

**Proposed Solution:**

Rebuild approximately 1.17 miles of Line #2019 between Thalia and Structure 2019/21 to current 230kV standards. The normal summer rating of the line segment will be 1047 MVA.

**Estimated Project Cost:** \$3.0 M

**Alternatives Considered:**

No feasible alternatives

**Project Target In-service Date:** 12/15/2025

**Project Status:** Conceptual

**Model:**



## Revision History

- 10/23/2020 – V1 – Original version posted to pjim.com.
- 11/02/2020 – V2 – Removed Pacific Loop and Poland Loop DNH
- 11/04/2020 – V3 – Updated DOM-2020-0019 project cost, DOM-2020-0044 wording update.
- 12/07/2020 – V4 – Updated DOM-2020-0019 to include an estimated distribution cost to give perspective on the total project cost. A note was also added after the “Alternatives Considered” section to clarify why the proposed solution was selected over the alternative to run a distribution circuit under the Mattaponi River.

# Dominion Supplemental Projects

Transmission Expansion Advisory  
Committee  
July 12, 2022



## Solutions

Stakeholders must submit any comments within 10 days of this meeting in order to provide time necessary to consider these comments prior to the next phase of the M-3 process

# Dominion Transmission Zone: Supplemental Equipment Material Condition, Performance and Risk

**Need Number:** DOM-2020-0036

**Process Stage:** Solutions Meeting 07/12/2022 - **UPDATE**

**Previously Presented:** Solutions Meeting 11/04/2020

**Project Driver:** Equipment Material Condition, Performance and Risk

**Specific Assumption References:**

See details on Equipment Material Condition, Performance and Risk in Dominion’s Planning Assumptions presented in December 2019 and updated in June 2020.

**Problem Statement:**

- Dominion Energy has identified a need to replace 60 concrete structures of Line #2007 (Lynnhaven – Thalia) based on the Company’s End of Life criteria.
- The 3.37 miles long line was constructed on concrete structures in 1970. These structures have developed significant structural concerns as they age.
- Every pole is experiencing hairline cracking at a minimum, and many of the poles have more advanced cracking that has exposed some of the interior reinforcing bars and cables.
- The cracks allow for significant water infiltration which can accelerate the deterioration of the concrete and cause rusting of the steel reinforcing components.
- The Line #2007 provides service to Thalia substation with approximately 134 MW of tapped load.
- **Dominion Energy acquired rights to use the existing right-of-way corridor containing Line #2007 which are nearing expiration.**

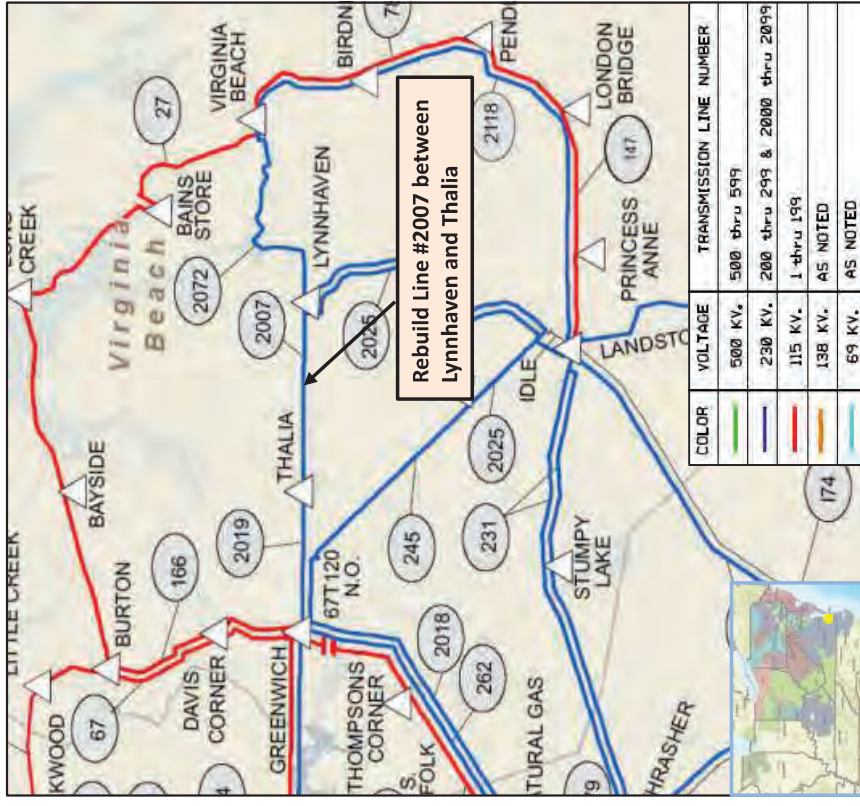

# Dominion Transmission Zone: Supplemental Line #2007 End-of-Life Rebuild – Lynnhaven to Thalia

**Need Number:** DOM-2020-0036

**Process Stage:** Solutions Meeting 07/12/2022

**Previously Presented:** Solutions Meeting 11/04/2020

**Proposed Solution:**

Rebuild the 3.37 miles long Line #2007 between Lynnhaven and Thalia to current 230kV standards. The normal summer rating of the line conductor will be ~~1047~~ 1573 MVA. **Dominion Energy to pursue with the City of Virginia Beach extending the rights for use of the existing Line #2007 corridor.**

36

**Estimated Project Cost:** \$7.0 \$28.7 M

**Alternatives Considered:**

No feasible alternatives

**Project Target In-service Date:** 12/31/2025

**Project Status:** Conceptual

**Model:** 2025 RTEP



# Dominion Transmission Zone: Supplemental Equipment Material Condition, Performance and Risk

**Need Number:** DOM-2020-0037

**Process Stage:** Solutions Meeting 07/12/2022 - **UPDATE**

**Previously Presented:** Solutions Meeting 11/04/2020

**Project Driver:** Equipment Material Condition, Performance and Risk

**Specific Assumption References:**

See details on Equipment Material Condition, Performance and Risk in Dominion’s Planning Assumptions presented in December 2019 and updated in June 2020.

**Problem Statement:**

Dominion Energy has identified a need to replace 20 concrete structures (Structure 2019/21 – Thalia segment) of Line #2019 (Greenwich – Thalia) based on the Company’s End of Life criteria.

- The 1.17 miles segment of Line #2019 was constructed on concrete structures in 1970. These structures have developed significant structural concerns as they age.
- Every pole is experiencing hairline cracking at a minimum, and many of the poles have more advanced cracking that has exposed some of the interior reinforcing bars and cables.
- The cracks allow for significant water infiltration which can accelerate the deterioration of the concrete and cause rusting of the steel reinforcing components.
- The Line #2019 provides service to Thalia substation with approximately 134 MW of tapped load.
- **Dominion Energy acquired rights to use the existing right-of-way corridor containing Line #2019 which are nearing expiration.**

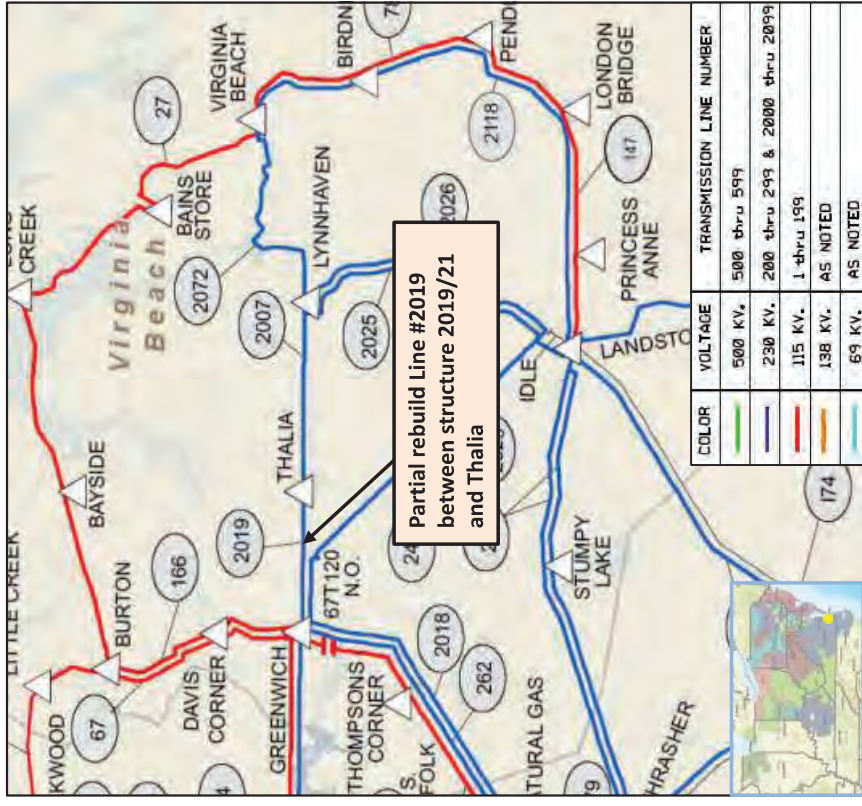

# Dominion Transmission Zone: Supplemental Line #2019 End-of-Life Partial Rebuild – Thalia to Greenwich

**Need Number:** DOM-2020-0037

**Process Stage:** Solutions Meeting 07/12/2022

**Previously Presented:** Solutions Meeting 11/04/2020

**Proposed Solution:**

Rebuild approximately 1.17 miles of Line #2019 between Thalia and Structure 2019/21 to current 230kV standards. The normal summer rating of the line segment will be ~~1047~~ 1573 MVA. Dominion Energy to pursue with the City of Virginia Beach extending the rights for use of the existing Line #2019 corridor.

**Estimated Project Cost:** ~~\$3.0~~ \$14.3 M

**Alternatives Considered:**

No feasible alternatives

**Project Target In-service Date:** ~~12/15/2025~~ 12/31/2025

**Project Status:** Conceptual

**Model:** 2025 RTEP

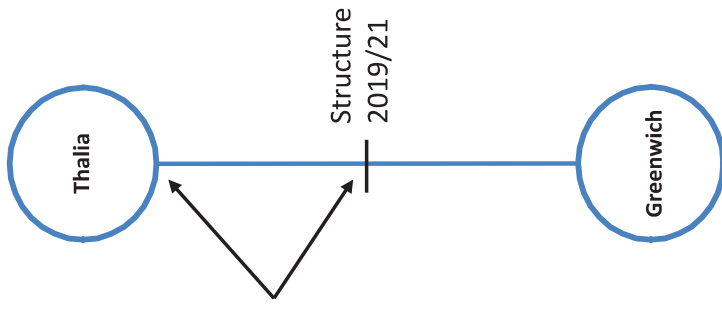

# Revision History

07/01/2022 – V1 – Original version posted to [pjm.com](mailto:pjm.com)

**I. NECESSITY FOR THE PROPOSED PROJECT**

**K. If the need for the proposed project is due in part to reliability issues and the proposed project is a rebuild of an existing transmission line(s), provide five years of outage history for the line(s), including for each outage the cause, duration and number of customers affected. Include a summary of the average annual number and duration of outages. Provide the average annual number and duration of outages on all Applicant circuits of the same voltage, as well as the total number of such circuits. In addition to outage history, provide five years of maintenance history on the line(s) to be rebuilt including a description of the work performed as well as the cost to complete the maintenance. Describe any system work already undertaken to address this outage history.**

Response: Not applicable. The need for the Rebuild Project is not driven by outage history, but rather by the need to replace transmission infrastructure approaching its end of life. See Section I.A of this Appendix.

**I. NECESSITY FOR THE PROPOSED PROJECT**

- L. If the need for the proposed project is due in part to deterioration of structures and associated equipment, provide representative photographs and inspection records detailing their condition.**

Response: The proposed Rebuild Project will replace aging infrastructure that is at the end of its service life.

See Attachments I.L.1.i through I.L.1.vi for representative photographs of the deterioration of the concrete poles supporting Lines #2019 and #2007 that have been identified for rebuild, and Attachment I.L.2 for the concrete pole inspection reports detailing the condition of those representative structures.



**Structure #2019/32**

Hairline cracking with efflorescence near the base of the pole.  
This is typical of most poles in the corridor.

---

**Deterioration Type:**  
**Hairline Cracking with Efflorescence**



**Structure #2019/34**

Substantial cracking with efflorescence continues approx. 15-20 FT above the base of the pole

---

**Deterioration Type:  
Substantial Cracking with Efflorescence**

Attachment I.L.1.ii



**Structure #2019/35**

Substantial cracking with major efflorescence near the base of the pole

---

**Deterioration Type:  
Substantial Cracking with Efflorescence**

Attachment I.L.1.iii





**Structure #2019/38**

Major cracking with exposed rebar near the base of the pole

---

**Deterioration Type:**  
**Major Cracking with Exposed Rebar**

Attachment I.L.1.iv



**Structure #2007/56**

Major cracking approx. 10 FT above the base of the pole

---

**Deterioration Type:**  
**Major Cracking**

Attachment I.L.1.v

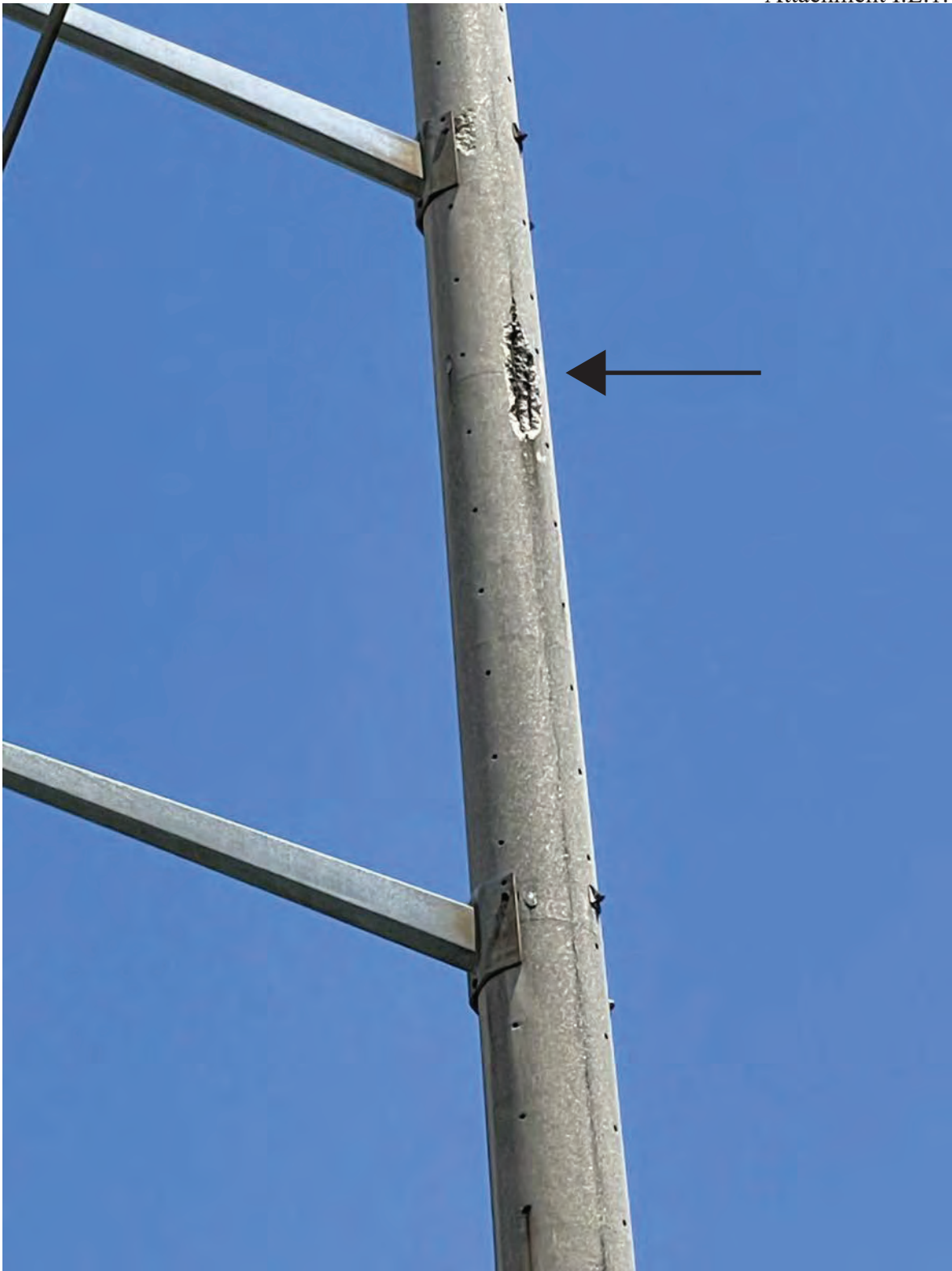

**Structure #2007/86**

Spalling has left rebar exposed and between lower and middle phases

**Deterioration Type:  
Spalling with Exposed Rebar**

Attachment I.L.1.vi

### CONCRETE POLE INSPECTION FORM

INSPECTOR'S INITIALS SH YEAR OF POLE 73 DATE OF INSPECTION 3-10-22

LINE NUMBER 2019 STR. NUMBER 1/A POLE POSITION Right Middle Left

HAIRLINE CRACKING ONLY: YES  NO

CRACKS GREATER THAN 1/8" THICK: YES  NO

Notes (typical Length): 1 foot

CRACKS W/ EFFLORESCENCE: YES  NO  (if yes, circle one) Min. 1 2 3 4 5

Notes: \_\_\_\_\_

REBAR/STRANDING VISIBLE: YES  NO

Notes: \_\_\_\_\_

NOTICEABLE RUST STAINING: YES  NO

Notes: \_\_\_\_\_

ADDITIONAL DAMAGE TO POLE: YES  NO

Notes: \_\_\_\_\_

ADDITIONAL COMMENTS:  
\_\_\_\_\_  
\_\_\_\_\_  
\_\_\_\_\_

CONCRETE POLE INSPECTION FORM

INSPECTOR'S INITIALS SH YEAR OF POLE 73 DATE OF INSPECTION 3-10-22

LINE NUMBER 2019 STR. NUMBER 1A POLE POSITION Right Middle Left

HAIRLINE CRACKING ONLY:  YES  NO

CRACKS GREATER THAN 1/8" THICK: YES  NO

Notes (typical Length): \_\_\_\_\_

CRACKS W/ EFFLORESCENCE:  YES  NO (if yes, circle one) Min. 1 2 3 4 5

Notes: 3 ft

REBAR/STRANDING VISIBLE:  YES  NO

Notes: chunks missing exposing rebar

NOTICEABLE RUST STAINING: YES  NO

Notes: \_\_\_\_\_

ADDITIONAL DAMAGE TO POLE:  YES  NO

Notes: chunks missing exposing rebar

ADDITIONAL COMMENTS:  
\_\_\_\_\_  
\_\_\_\_\_  
\_\_\_\_\_

CONCRETE POLE INSPECTION FORM

INSPECTOR'S INITIALS SH YEAR OF POLE 87 DATE OF INSPECTION 3-10-22

LINE NUMBER 2019 STR. NUMBER 2 POLE POSITION Right Middle Left

HAIRLINE CRACKING ONLY:  YES  NO  
CRACKS GREATER THAN 1/8" THICK: YES  NO

Notes (typical Length): \_\_\_\_\_

CRACKS W/ EFFLORESCENCE:  YES  NO (if yes, circle one) Min. 1 2 3 4 5  
Notes: 3 Cr

REBAR/STRANDING VISIBLE: YES  NO  
Notes: \_\_\_\_\_

NOTICEABLE RUST STAINING: YES  NO  
Notes: \_\_\_\_\_

ADDITIONAL DAMAGE TO POLE: YES  NO  
Notes: \_\_\_\_\_

ADDITIONAL COMMENTS:  
\_\_\_\_\_  
\_\_\_\_\_  
\_\_\_\_\_

**CONCRETE POLE INSPECTION FORM**

INSPECTOR'S INITIALS SH YEAR OF POLE 88 DATE OF INSPECTION 3-10-22

LINE NUMBER 2019 STR. NUMBER 5 POLE POSITION Right Middle Left

HAIRLINE CRACKING ONLY:  YES  NO

CRACKS GREATER THAN 1/8" THICK:  YES  NO

Notes (typical Length): \_\_\_\_\_

CRACKS W/ EFFLORESCENCE:  YES  NO (if yes, circle one) Min.  1  2  3  4  5

Notes: \_\_\_\_\_

REBAR/STRANDING VISIBLE: YES  NO

Notes: \_\_\_\_\_

NOTICEABLE RUST STAINING: YES  NO

Notes: \_\_\_\_\_

ADDITIONAL DAMAGE TO POLE: YES  NO

Notes: \_\_\_\_\_

ADDITIONAL COMMENTS:  
\_\_\_\_\_  
\_\_\_\_\_  
\_\_\_\_\_

**CONCRETE POLE INSPECTION FORM**

INSPECTOR'S INITIALS SK YEAR OF POLE 88 DATE OF INSPECTION 3-10-00

LINE NUMBER 2019 STR. NUMBER 6 POLE POSITION Right Middle Left

HAIRLINE CRACKING ONLY:  YES  NO

CRACKS GREATER THAN 1/8" THICK:  YES  NO

Notes (typical Length): 4' foot

CRACKS W/ EFFLORESCENCE:  YES  NO (if yes, circle one) Min. 1 2 3 4 5

Notes: \_\_\_\_\_

REBAR/STRANDING VISIBLE: YES  NO

Notes: \_\_\_\_\_

NOTICEABLE RUST STAINING: YES  NO

Notes: \_\_\_\_\_

ADDITIONAL DAMAGE TO POLE: YES  NO

Notes: \_\_\_\_\_

ADDITIONAL COMMENTS:  
\_\_\_\_\_  
\_\_\_\_\_  
\_\_\_\_\_

**CONCRETE POLE INSPECTION FORM**

INSPECTOR'S INITIALS SH YEAR OF POLE 88 DATE OF INSPECTION 3-10-22

LINE NUMBER 2019 STR. NUMBER 7 POLE POSITION Right Middle Left

HAIRLINE CRACKING ONLY:  YES  NO

CRACKS GREATER THAN 1/8" THICK: YES   NO

Notes (typical Length): \_\_\_\_\_

CRACKS W/ EFFLORESCENCE:  YES  NO (if yes, circle one) Min.  1  2  3  4  5

Notes: \_\_\_\_\_

REBAR/STRANDING VISIBLE: YES   NO

Notes: \_\_\_\_\_

NOTICEABLE RUST STAINING: YES   NO

Notes: \_\_\_\_\_

ADDITIONAL DAMAGE TO POLE: YES   NO

Notes: \_\_\_\_\_

ADDITIONAL COMMENTS:

\_\_\_\_\_  
\_\_\_\_\_  
\_\_\_\_\_

**CONCRETE POLE INSPECTION FORM**

INSPECTOR'S INITIALS 54 YEAR OF POLE 88 DATE OF INSPECTION 3-10-22

LINE NUMBER 2019 STR. NUMBER 8 POLE POSITION Right Middle Left

HAIRLINE CRACKING ONLY:

YES  NO

CRACKS GREATER THAN 1/8" THICK:

YES  NO

Notes (typical Length): \_\_\_\_\_

CRACKS W/ EFFLORESCENCE:

YES  NO (if yes, circle one) Min.  1  2  3  4  5

Notes: Very minimal \_\_\_\_\_

REBAR/STRANDING VISIBLE:

YES  NO

Notes: \_\_\_\_\_

NOTICEABLE RUST STAINING:

YES  NO

Notes: \_\_\_\_\_

ADDITIONAL DAMAGE TO POLE:

YES  NO

Notes: \_\_\_\_\_

ADDITIONAL COMMENTS:

\_\_\_\_\_  
\_\_\_\_\_  
\_\_\_\_\_

**CONCRETE POLE INSPECTION FORM**

INSPECTOR'S INITIALS S'H YEAR OF POLE 88 DATE OF INSPECTION 3-10-22

LINE NUMBER 2019 STR. NUMBER 18 POLE POSITION Right Middle Left

HAIRLINE CRACKING ONLY: YES NO

CRACKS GREATER THAN 1/8" THICK: YES NO

Notes (typical Length): C FL

CRACKS W/ EFFLORESCENCE: YES NO (if yes, circle one) Min. 1  2 3 4 5

Notes: \_\_\_\_\_

REBAR/STRANDING VISIBLE: YES NO

Notes: \_\_\_\_\_

NOTICEABLE RUST STAINING: YES NO

Notes: \_\_\_\_\_

ADDITIONAL DAMAGE TO POLE: YES NO

Notes: \_\_\_\_\_

ADDITIONAL COMMENTS:  
Some cracks larger than 1/4 but they  
are not long less than 8 ft

CONCRETE POLE INSPECTION FORM

INSPECTOR'S INITIALS SH YEAR OF POLE 88 DATE OF INSPECTION 3-10-22

LINE NUMBER 2019 STR. NUMBER 19 POLE POSITION Right Middle Left

HAIRLINE CRACKING ONLY:  YES  NO

CRACKS GREATER THAN 1/8" THICK: YES  NO

Notes (typical Length): \_\_\_\_\_

CRACKS W/ EFFLORESCENCE:  YES  NO (if yes, circle one) Min.  1 2 3 4 5

Notes: \_\_\_\_\_

REBAR/STRANDING VISIBLE: YES  NO

Notes: \_\_\_\_\_

NOTICEABLE RUST STAINING: YES  NO

Notes: \_\_\_\_\_

ADDITIONAL DAMAGE TO POLE: YES  NO

Notes: minor chips taken out at Bottom  
Broken Kernal

ADDITIONAL COMMENTS:

\_\_\_\_\_  
\_\_\_\_\_  
\_\_\_\_\_

CONCRETE POLE INSPECTION FORM

INSPECTOR'S INITIALS SH YEAR OF POLE 69 DATE OF INSPECTION 3-28-22

LINE NUMBER 2019 STR. NUMBER 21 POLE POSITION Right Middle Left

HAIRLINE CRACKING ONLY: YES  NO

CRACKS GREATER THAN 1/8" THICK: YES  NO

Notes (typical Length): 8 ft

CRACKS W/ EFFLORESCENCE: YES  NO  (if yes, circle one) Min. 1 2  4 5

Notes: at Bottom

REBAR/STRANDING VISIBLE: YES  NO

Notes:

NOTICEABLE RUST STAINING: YES  NO

Notes:

ADDITIONAL DAMAGE TO POLE: YES  NO

Notes: Small chips in Pole

ADDITIONAL COMMENTS:

\_\_\_\_\_  
\_\_\_\_\_  
\_\_\_\_\_

CONCRETE POLE INSPECTION FORM

INSPECTOR'S INITIALS JWJ YEAR OF POLE N/A DATE OF INSPECTION 3/28/22

LINE NUMBER 2019 STR. NUMBER 22 POLE POSITION  Right  Middle  Left

HAIRLINE CRACKING ONLY: YES  NO

CRACKS GREATER THAN 1/8" THICK: YES  NO

Notes (typical Length): 10 ft at bottom

CRACKS W/ EFFLORESCENCE: YES  NO  (if yes, circle one) Min. 1  2  3  4  5

Notes: Bottom of pole

REBAR/STRANDING VISIBLE: YES  NO

Notes: Bottom of pole

NOTICEABLE RUST STAINING: YES  NO

Notes: \_\_\_\_\_

ADDITIONAL DAMAGE TO POLE: YES  NO

Notes: Chipping at bottom

ADDITIONAL COMMENTS:

\_\_\_\_\_  
\_\_\_\_\_  
\_\_\_\_\_

### CONCRETE POLE INSPECTION FORM

INSPECTOR'S INITIALS Ques YEAR OF POLE 1969 DATE OF INSPECTION 3/28/22

LINE NUMBER 2019 STR. NUMBER 23 POLE POSITION  Right  Middle  Left

HAIRLINE CRACKING ONLY: YES  NO

CRACKS GREATER THAN 1/8" THICK: YES  NO

Notes (typical Length): 20ft start at bottom

CRACKS W/ EFFLORESCENCE: YES  NO  (if yes, circle one) Min. 1 2 3 4  5

Notes: Bottom of pole

REBAR/STRANDING VISIBLE: YES  NO

Notes:

NOTICEABLE RUST STAINING: YES  NO

Notes:

ADDITIONAL DAMAGE TO POLE: YES  NO

Notes:

ADDITIONAL COMMENTS:

\_\_\_\_\_  
\_\_\_\_\_  
\_\_\_\_\_

**CONCRETE POLE INSPECTION FORM**

INSPECTOR'S INITIALS JWJ YEAR OF POLE N/A DATE OF INSPECTION 3/28/22

LINE NUMBER 2019 STR. NUMBER 24 POLE POSITION  Right  Middle  Left

HAIRLINE CRACKING ONLY: YES  NO

CRACKS GREATER THAN 1/8" THICK: YES  NO

Notes (typical Length): 8ft at bottom

CRACKS W/ EFFLORESCENCE: YES  NO  (if yes, circle one) Min. 1 2  4 5

Notes: At bottom

REBAR/STRANDING VISIBLE: YES  NO

Notes: \_\_\_\_\_

NOTICEABLE RUST STAINING: YES  NO

Notes: \_\_\_\_\_

ADDITIONAL DAMAGE TO POLE: YES  NO

Notes: Chipping

ADDITIONAL COMMENTS:  
\_\_\_\_\_  
\_\_\_\_\_  
\_\_\_\_\_

**CONCRETE POLE INSPECTION FORM**

INSPECTOR'S INITIALS JWJ YEAR OF POLE 1969 DATE OF INSPECTION 3/28/22

LINE NUMBER 209 STR. NUMBER 25 POLE POSITION  Right  Middle  Left

HAIRLINE CRACKING ONLY: YES  NO

CRACKS GREATER THAN 1/8" THICK: YES  NO

Notes (typical Length): 15ft at bottom

CRACKS W/ EFFLORESCENCE: YES  NO  (if yes, circle one) Min.  1  2  3  4  5

Notes: At bottom

REBAR/STRANDING VISIBLE: YES  NO

Notes:

NOTICEABLE RUST STAINING: YES  NO

Notes:

ADDITIONAL DAMAGE TO POLE: YES  NO

Notes: Chipping

ADDITIONAL COMMENTS:  
\_\_\_\_\_  
\_\_\_\_\_  
\_\_\_\_\_

CONCRETE POLE INSPECTION FORM

INSPECTOR'S INITIALS fw YEAR OF POLE 1970 DATE OF INSPECTION 3/28/22

LINE NUMBER 2019 STR. NUMBER 26 POLE POSITION Right Middle Left

HAIRLINE CRACKING ONLY: YES  NO

CRACKS GREATER THAN 1/8" THICK: YES  NO

Notes (typical Length): 10ft at bottom

CRACKS W/ EFFLORESCENCE: YES  NO  (if yes, circle one) Min. 1 2 3 4 5

Notes: All over from bottom to about 35ft up

REBAR/STRANDING VISIBLE: YES  NO

Notes: \_\_\_\_\_

NOTICEABLE RUST STAINING: YES  NO

Notes: \_\_\_\_\_

ADDITIONAL DAMAGE TO POLE: YES  NO

Notes: Chipping

ADDITIONAL COMMENTS:  
\_\_\_\_\_  
\_\_\_\_\_  
\_\_\_\_\_

**CONCRETE POLE INSPECTION FORM**

INSPECTOR'S INITIALS April YEAR OF POLE 1989 DATE OF INSPECTION 3/28/22

LINE NUMBER 209 STR. NUMBER 27 POLE POSITION  Right  Middle  Left

HAIRLINE CRACKING ONLY:  YES  NO

CRACKS GREATER THAN 1/8" THICK:  YES  NO

Notes (typical Length): \_\_\_\_\_

CRACKS W/ EFFLORESCENCE:  YES  NO (if yes, circle one) Min.  1  2  3  4  5

Notes: 1 ft section only

REBAR/STRANDING VISIBLE:  YES  NO

Notes: \_\_\_\_\_

NOTICEABLE RUST STAINING:  YES  NO

Notes: \_\_\_\_\_

ADDITIONAL DAMAGE TO POLE:  YES  NO

Notes: \_\_\_\_\_

ADDITIONAL COMMENTS:

Pole in good shape

CONCRETE POLE INSPECTION FORM

INSPECTOR'S INITIALS Jmf YEAR OF POLE N/A DATE OF INSPECTION 3/28/22

LINE NUMBER 2019 STR. NUMBER 28 POLE POSITION  Right  Middle  Left

HAIRLINE CRACKING ONLY: YES  NO

CRACKS GREATER THAN 1/8" THICK:  YES  NO

Notes (typical Length): About 10ft at bottom

CRACKS W/ EFFLORESCENCE: YES  NO  (if yes, circle one) Min. 1 2 3  4 5

Notes: At bottom

REBAR/STRANDING VISIBLE: YES  NO

Notes: \_\_\_\_\_

NOTICEABLE RUST STAINING: YES  NO

Notes: \_\_\_\_\_

ADDITIONAL DAMAGE TO POLE:  YES  NO

Notes: Chipping

ADDITIONAL COMMENTS:  
\_\_\_\_\_  
\_\_\_\_\_  
\_\_\_\_\_

**CONCRETE POLE INSPECTION FORM**

INSPECTOR'S INITIALS Jel YEAR OF POLE 1989 DATE OF INSPECTION 3/28/22

LINE NUMBER 2019 STR. NUMBER 29 POLE POSITION  Right  Middle  Left

HAIRLINE CRACKING ONLY: YES  NO

CRACKS GREATER THAN 1/8" THICK: YES  NO

Notes (typical Length): As bottom

CRACKS W/ EFFLORESCENCE: YES  NO  (if yes, circle one) Min. 1  2  3  4  5

Notes: As bottom

REBAR/STRANDING VISIBLE: YES  NO

Notes:

NOTICEABLE RUST STAINING: YES  NO

Notes:

ADDITIONAL DAMAGE TO POLE: YES  NO

Notes: Chipping

ADDITIONAL COMMENTS:

\_\_\_\_\_  
\_\_\_\_\_  
\_\_\_\_\_

CONCRETE POLE INSPECTION FORM

INSPECTOR'S INITIALS mf YEAR OF POLE N/A DATE OF INSPECTION 3/28/22

LINE NUMBER 2019 STR. NUMBER 30 POLE POSITION  Right  Middle  Left

HAIRLINE CRACKING ONLY: YES  NO

CRACKS GREATER THAN 1/8" THICK: YES  NO

Notes (typical Length): 10ft at bottom

CRACKS W/ EFFLORESCENCE: YES  NO  (if yes, circle one) Min.  1  2  3  4  5

Notes: At bottom

REBAR/STRANDING VISIBLE: YES  NO

Notes:

NOTICEABLE RUST STAINING: YES  NO

Notes:

ADDITIONAL DAMAGE TO POLE: YES  NO

Notes: Chipping

ADDITIONAL COMMENTS:  
\_\_\_\_\_  
\_\_\_\_\_  
\_\_\_\_\_

**CONCRETE POLE INSPECTION FORM**

INSPECTOR'S INITIALS AWJ YEAR OF POLE 1979 DATE OF INSPECTION 3/28/72

LINE NUMBER 2019 STR. NUMBER 31 POLE POSITION  Right  Middle  Left

HAIRLINE CRACKING ONLY: YES  NO

CRACKS GREATER THAN 1/8" THICK:  YES  NO

Notes (typical Length): 25ft as bottom

CRACKS W/ EFFLORESCENCE:  YES  NO (if yes, circle one) Min.  1  2  3  4  5

Notes: At bottom

REBAR/STRANDING VISIBLE:  YES  NO

Notes: 20ft up

NOTICEABLE RUST STAINING: YES  NO

Notes: \_\_\_\_\_

ADDITIONAL DAMAGE TO POLE:  YES  NO

Notes: Chipping

ADDITIONAL COMMENTS:

\_\_\_\_\_  
\_\_\_\_\_  
\_\_\_\_\_

**CONCRETE POLE INSPECTION FORM**

INSPECTOR'S INITIALS AW YEAR OF POLE N/A DATE OF INSPECTION 3/28/22

LINE NUMBER 2019 STR. NUMBER 32 POLE POSITION  Right  Middle  Left

HAIRLINE CRACKING ONLY: YES  NO

CRACKS GREATER THAN 1/8" THICK: YES  NO

Notes (typical Length): 10ft top bottom

CRACKS W/ EFFLORESCENCE: YES  NO  (if yes, circle one) Min. 1 2 3 4 5

Notes: At bottom

REBAR/STRANDING VISIBLE: YES  NO

Notes: \_\_\_\_\_

NOTICEABLE RUST STAINING: YES  NO

Notes: \_\_\_\_\_

ADDITIONAL DAMAGE TO POLE: YES  NO

Notes: Chipping

ADDITIONAL COMMENTS:

\_\_\_\_\_  
\_\_\_\_\_  
\_\_\_\_\_

**CONCRETE POLE INSPECTION FORM**

INSPECTOR'S INITIALS AW YEAR OF POLE NA DATE OF INSPECTION 3/28/22

LINE NUMBER 2019 STR. NUMBER 33 POLE POSITION Right Middle Left

HAIRLINE CRACKING ONLY: YES  NO

CRACKS GREATER THAN 1/8" THICK: YES  NO

Notes (typical Length): At bottom up 20 ft

CRACKS W/ EFFLORESCENCE: YES  NO  (if yes, circle one) Min. 1 2  4 5

Notes: Bottom

REBAR/STRANDING VISIBLE: YES  NO

Notes:

NOTICEABLE RUST STAINING: YES  NO

Notes:

ADDITIONAL DAMAGE TO POLE: YES  NO

Notes: Chipping

ADDITIONAL COMMENTS:

\_\_\_\_\_  
\_\_\_\_\_  
\_\_\_\_\_

**CONCRETE POLE INSPECTION FORM**

INSPECTOR'S INITIALS JWJ YEAR OF POLE 1969 DATE OF INSPECTION 5/28/22

LINE NUMBER 2019 STR. NUMBER 34 POLE POSITION Right Middle Left

HAIRLINE CRACKING ONLY:

YES  NO

CRACKS GREATER THAN 1/8" THICK:

YES NO

Notes (typical Length): At bottom

CRACKS W/ EFFLORESCENCE:

YES NO (if yes, circle one) Min. 1 2 3 4 5

Notes: Bottom

REBAR/STRANDING VISIBLE:

YES  NO

Notes:

NOTICEABLE RUST STAINING:

YES  NO

Notes:

ADDITIONAL DAMAGE TO POLE:

YES NO

Notes: Chipping

ADDITIONAL COMMENTS:

\_\_\_\_\_  
\_\_\_\_\_  
\_\_\_\_\_

**CONCRETE POLE INSPECTION FORM**

INSPECTOR'S INITIALS AWJ YEAR OF POLE N/A DATE OF INSPECTION 3/28/22

LINE NUMBER 2019 STR. NUMBER 35 POLE POSITION Right Middle Left

HAIRLINE CRACKING ONLY: YES  NO

CRACKS GREATER THAN 1/8" THICK: YES  NO

Notes (typical Length): Bottom

CRACKS W/ EFFLORESCENCE: YES  NO  (if yes, circle one) Min. 1 2 3 4 5

Notes: Bottom

REBAR/STRANDING VISIBLE: YES  NO

Notes: \_\_\_\_\_

NOTICEABLE RUST STAINING: YES  NO

Notes: \_\_\_\_\_

ADDITIONAL DAMAGE TO POLE: YES  NO

Notes: Chipping

ADDITIONAL COMMENTS:

\_\_\_\_\_  
\_\_\_\_\_  
\_\_\_\_\_

CONCRETE POLE INSPECTION FORM

INSPECTOR'S INITIALS AWL YEAR OF POLE N/A DATE OF INSPECTION 3/28/22

LINE NUMBER 2019 STR. NUMBER 36 POLE POSITION  Right  Middle  Left

HAIRLINE CRACKING ONLY: YES  NO

CRACKS GREATER THAN 1/8" THICK: YES  NO

Notes (typical Length): Bottom

CRACKS W/ EFFLORESCENCE: YES  NO  (if yes, circle one) Min. 1 2 3 4 5

Notes: \_\_\_\_\_

REBAR/STRANDING VISIBLE: YES  NO

Notes: \_\_\_\_\_

NOTICEABLE RUST STAINING: YES  NO

Notes: \_\_\_\_\_

ADDITIONAL DAMAGE TO POLE: YES  NO

Notes: Chipping

ADDITIONAL COMMENTS:  
\_\_\_\_\_  
\_\_\_\_\_  
\_\_\_\_\_

CONCRETE POLE INSPECTION FORM

INSPECTOR'S INITIALS Good YEAR OF POLE NA DATE OF INSPECTION 3/20/22

LINE NUMBER 2019 STR. NUMBER 57 POLE POSITION  Right  Middle  Left

HAIRLINE CRACKING ONLY: YES  NO

CRACKS GREATER THAN 1/8" THICK: YES  NO

Notes (typical Length): At Bottom

CRACKS W/ EFFLORESCENCE: YES  NO  (if yes, circle one) Min.  1  2  3  4  5

Notes: bottom

REBAR/STRANDING VISIBLE: YES  NO

Notes:

NOTICEABLE RUST STAINING: YES  NO

Notes:

ADDITIONAL DAMAGE TO POLE: YES  NO

Notes: Chipping

ADDITIONAL COMMENTS:

\_\_\_\_\_  
\_\_\_\_\_  
\_\_\_\_\_

**CONCRETE POLE INSPECTION FORM**

INSPECTOR'S INITIALS GHJ YEAR OF POLE N/A DATE OF INSPECTION 3/28/22

LINE NUMBER 2019 STR. NUMBER 38 POLE POSITION  Right  Middle  Left

HAIRLINE CRACKING ONLY: YES  NO

CRACKS GREATER THAN 1/8" THICK: YES  NO

Notes (typical Length): Bottom

CRACKS W/ EFFLORESCENCE: YES  NO  (if yes, circle one) Min.  1  2  3  4  5

Notes: Bottom

REBAR/STRANDING VISIBLE: YES  NO

Notes: Bottom

NOTICEABLE RUST STAINING: YES  NO

Notes: \_\_\_\_\_

ADDITIONAL DAMAGE TO POLE: YES  NO

Notes: Chipping

ADDITIONAL COMMENTS:

\_\_\_\_\_  
\_\_\_\_\_  
\_\_\_\_\_

**CONCRETE POLE INSPECTION FORM**

INSPECTOR'S INITIALS Jwd YEAR OF POLE NA DATE OF INSPECTION 3/28/22

LINE NUMBER 2019 STR. NUMBER 39 POLE POSITION  Right  Middle  Left

HAIRLINE CRACKING ONLY: YES  NO

CRACKS GREATER THAN 1/8" THICK: YES  NO

Notes (typical Length): Bottom 20ft

CRACKS W/ EFFLORESCENCE: YES  NO  (if yes, circle one) Min.  1  2  3  4  5

Notes: \_\_\_\_\_

REBAR/STRANDING VISIBLE: YES  NO

Notes: \_\_\_\_\_

NOTICEABLE RUST STAINING: YES  NO

Notes: \_\_\_\_\_

ADDITIONAL DAMAGE TO POLE: YES  NO

Notes: Chipping

ADDITIONAL COMMENTS:

\_\_\_\_\_  
\_\_\_\_\_  
\_\_\_\_\_

**CONCRETE POLE INSPECTION FORM**

INSPECTOR'S INITIALS Jad YEAR OF POLE \_\_\_\_\_ DATE OF INSPECTION 3/28/22

LINE NUMBER 2019 STR. NUMBER 40 POLE POSITION Right Middle Left

HAIRLINE CRACKING ONLY: YES  NO

CRACKS GREATER THAN 1/8" THICK: YES  NO

Notes (typical Length): Bottom 10ft

CRACKS W/ EFFLORESCENCE: YES  NO  (if yes, circle one) Min. 1 2 3 4 5

Notes: \_\_\_\_\_

REBAR/STRANDING VISIBLE: YES  NO

Notes: \_\_\_\_\_

NOTICEABLE RUST STAINING: YES  NO

Notes: \_\_\_\_\_

ADDITIONAL DAMAGE TO POLE: YES  NO

Notes: Chipping

ADDITIONAL COMMENTS:

\_\_\_\_\_  
\_\_\_\_\_  
\_\_\_\_\_

**CONCRETE POLE INSPECTION FORM**

INSPECTOR'S INITIALS JS YEAR OF POLE no Date DATE OF INSPECTION 7/11/19

LINE NUMBER 2007 STR. NUMBER 43 POLE POSITION Right Middle Left

**HAIRLINE CRACKING ONLY:**

YES  NO

**CRACKS GREATER THAN 1/8" THICK:**

YES  NO

Notes (typical Length): \_\_\_\_\_

**CRACKS W/ EFFLORESCENCE:**

YES  NO (if yes, circle one) Min.  1  2  3  4  5

Notes: \_\_\_\_\_

**REBAR/STRANDING VISIBLE:**

YES  NO

Notes: \_\_\_\_\_

**NOTICEABLE RUST STAINING:**

YES  NO

Notes: \_\_\_\_\_

**ADDITIONAL DAMAGE TO POLE:**

YES  NO

Notes: \_\_\_\_\_

**ADDITIONAL COMMENTS:**

\_\_\_\_\_  
\_\_\_\_\_  
\_\_\_\_\_

**CONCRETE POLE INSPECTION FORM**

INSPECTOR'S INITIALS ES YEAR OF POLE 8/17 DATE OF INSPECTION 7/11/19

LINE NUMBER 2007 STR. NUMBER 44 POLE POSITION Right Middle Left

HAIRLINE CRACKING ONLY:  YES  NO

CRACKS GREATER THAN 1/8" THICK:  YES  NO

Notes (typical Length): 10'-15'

CRACKS W/ EFFLORESCENCE:  YES  NO (if yes, circle one) Min. 1 2 3 4 5

Notes: \_\_\_\_\_

REBAR/STRANDING VISIBLE: YES  NO

Notes: \_\_\_\_\_

NOTICEABLE RUST STAINING: YES  NO

Notes: \_\_\_\_\_

ADDITIONAL DAMAGE TO POLE: YES  NO

Notes: \_\_\_\_\_

ADDITIONAL COMMENTS:

\_\_\_\_\_  
\_\_\_\_\_  
\_\_\_\_\_

**CONCRETE POLE INSPECTION FORM**

INSPECTOR'S INITIALS JS YEAR OF POLE 0/69 DATE OF INSPECTION 7/11/19

LINE NUMBER 2007 STR. NUMBER 45 POLE POSITION Right Middle Left

**HAIRLINE CRACKING ONLY:**

YES  NO

**CRACKS GREATER THAN 1/8" THICK:**

YES  NO

Notes (typical Length): \_\_\_\_\_

\_\_\_\_\_

**CRACKS W/ EFFLORESCENCE:**

YES  NO (if yes, circle one) Min. 1 2  3 4 5

Notes: \_\_\_\_\_

\_\_\_\_\_

**REBAR/STRANDING VISIBLE:**

YES  NO

Notes: \_\_\_\_\_

\_\_\_\_\_

**NOTICEABLE RUST STAINING:**

YES  NO

Notes: \_\_\_\_\_

\_\_\_\_\_

**ADDITIONAL DAMAGE TO POLE:**

YES  NO

Notes: \_\_\_\_\_

\_\_\_\_\_

**ADDITIONAL COMMENTS:**

\_\_\_\_\_  
\_\_\_\_\_  
\_\_\_\_\_

**CONCRETE POLE INSPECTION FORM**

INSPECTOR'S INITIALS B3 YEAR OF POLE 8/27 DATE OF INSPECTION 7/11/19

LINE NUMBER 2007 STR. NUMBER 46 POLE POSITION Right Middle Left

HAIRLINE CRACKING ONLY: YES  NO

CRACKS GREATER THAN 1/8" THICK: YES  NO

Notes (typical Length): \_\_\_\_\_

\_\_\_\_\_

CRACKS W/ EFFLORESCENCE: YES  NO  (if yes, circle one) Min. 1 2 3 4 5

Notes: \_\_\_\_\_

\_\_\_\_\_

REBAR/STRANDING VISIBLE: YES  NO

Notes: \_\_\_\_\_

\_\_\_\_\_

NOTICEABLE RUST STAINING: YES  NO

Notes: \_\_\_\_\_

\_\_\_\_\_

ADDITIONAL DAMAGE TO POLE: YES  NO

Notes: \_\_\_\_\_

\_\_\_\_\_

ADDITIONAL COMMENTS:

\_\_\_\_\_

\_\_\_\_\_

\_\_\_\_\_

### CONCRETE POLE INSPECTION FORM

INSPECTOR'S INITIALS SS YEAR OF POLE N/A DATE OF INSPECTION 7/11/19

LINE NUMBER 2007 STR. NUMBER 47 POLE POSITION  Right  Middle  Left

HAIRLINE CRACKING ONLY:

YES  NO

CRACKS GREATER THAN 1/8" THICK:

YES  NO

Notes (typical Length): \_\_\_\_\_

CRACKS W/ EFFLORESCENCE:

YES  NO

(if yes, circle one) Min. 1 2 3 4 5

Notes: \_\_\_\_\_

REBAR/STRANDING VISIBLE:

YES  NO

Notes: \_\_\_\_\_

NOTICEABLE RUST STAINING:

YES  NO

Notes: \_\_\_\_\_

ADDITIONAL DAMAGE TO POLE:

YES  NO

Notes: \_\_\_\_\_

ADDITIONAL COMMENTS:

\_\_\_\_\_  
\_\_\_\_\_  
\_\_\_\_\_

CONCRETE POLE INSPECTION FORM

INSPECTOR'S INITIALS B YEAR OF POLE 1/70 DATE OF INSPECTION 7/11/19

LINE NUMBER 2007 STR. NUMBER 48 POLE POSITION Right Middle Left

HAIRLINE CRACKING ONLY:  YES  NO

CRACKS GREATER THAN 1/8" THICK:  YES  NO

Notes (typical Length): 5 Ft

CRACKS W/ EFFLORESCENCE:  YES  NO (if yes, circle one) Min. 1 2 3 4 5

Notes:

REBAR/STRANDING VISIBLE:  YES  NO

Notes:

NOTICEABLE RUST STAINING: YES  NO

Notes:

ADDITIONAL DAMAGE TO POLE: YES  NO

Notes:

ADDITIONAL COMMENTS:

\_\_\_\_\_  
\_\_\_\_\_  
\_\_\_\_\_

**CONCRETE POLE INSPECTION FORM**

INSPECTOR'S INITIALS SS YEAR OF POLE 2018 DATE OF INSPECTION 7/10/19

LINE NUMBER 2007 STR. NUMBER 49 POLE POSITION Right Middle Left

HAIRLINE CRACKING ONLY:

YES  NO

CRACKS GREATER THAN 1/8" THICK:

YES  NO

Notes (typical Length): \_\_\_\_\_

\_\_\_\_\_

CRACKS W/ EFFLORESCENCE:

YES  NO (if yes, circle one) Min. 1  2  3  4  5

Notes: \_\_\_\_\_

\_\_\_\_\_

REBAR/STRANDING VISIBLE:

YES  NO

Notes: \_\_\_\_\_

\_\_\_\_\_

NOTICEABLE RUST STAINING:

YES  NO

Notes: \_\_\_\_\_

\_\_\_\_\_

ADDITIONAL DAMAGE TO POLE:

YES  NO

Notes: \_\_\_\_\_

\_\_\_\_\_

ADDITIONAL COMMENTS:

\_\_\_\_\_  
\_\_\_\_\_  
\_\_\_\_\_

**CONCRETE POLE INSPECTION FORM**

INSPECTOR'S INITIALS JS YEAR OF POLE 2011A DATE OF INSPECTION 7/11/19

LINE NUMBER 2007 STR. NUMBER 50 POLE POSITION Right Middle Left

HAIRLINE CRACKING ONLY:

YES  NO

CRACKS GREATER THAN 1/8" THICK:

YES  NO

Notes (typical Length): \_\_\_\_\_

CRACKS W/ EFFLORESCENCE:

YES  NO (if yes, circle one) Min. 1 2 3 4 5

Notes: \_\_\_\_\_

REBAR/STRANDING VISIBLE:

YES  NO

Notes: \_\_\_\_\_

NOTICEABLE RUST STAINING:

YES  NO

Notes: \_\_\_\_\_

ADDITIONAL DAMAGE TO POLE:

YES  NO

Notes: \_\_\_\_\_

ADDITIONAL COMMENTS:

\_\_\_\_\_  
\_\_\_\_\_  
\_\_\_\_\_

**CONCRETE POLE INSPECTION FORM**

INSPECTOR'S INITIALS JS YEAR OF POLE 3/10 DATE OF INSPECTION 7/11/19

LINE NUMBER 2007 STR. NUMBER 51 POLE POSITION Right Middle Left

HAIRLINE CRACKING ONLY:

YES  NO

CRACKS GREATER THAN 1/8" THICK:

YES  NO

Notes (typical Length): 20 FT

CRACKS W/ EFFLORESCENCE:

YES  NO

(if yes, circle one) Min. 1 2 3 4 5

Notes:

REBAR/STRANDING VISIBLE:

YES  NO

Notes:

NOTICEABLE RUST STAINING:

YES

NO

Notes:

ADDITIONAL DAMAGE TO POLE:

YES

NO

Notes:

ADDITIONAL COMMENTS:

CONCRETE POLE INSPECTION FORM

INSPECTOR'S INITIALS JS YEAR OF POLE 1969 DATE OF INSPECTION 7/11/19

LINE NUMBER 2007 STR. NUMBER 52 POLE POSITION  Right  Middle  Left

HAIRLINE CRACKING ONLY:  YES  NO

CRACKS GREATER THAN 1/8" THICK:  YES  NO

Notes (typical Length): 10 FT

CRACKS W/ EFFLORESCENCE:  YES  NO (if yes, circle one) Min. 1 2  3 4 5

Notes:

REBAR/STRANDING VISIBLE:  YES  NO

Notes:

NOTICEABLE RUST STAINING: YES  NO

Notes:

ADDITIONAL DAMAGE TO POLE: YES  NO

Notes:

ADDITIONAL COMMENTS:

\_\_\_\_\_  
\_\_\_\_\_  
\_\_\_\_\_

**CONCRETE POLE INSPECTION FORM**

INSPECTOR'S INITIALS JS YEAR OF POLE 01/69 DATE OF INSPECTION 7/11/19

LINE NUMBER 2007 STR. NUMBER 53 POLE POSITION Right Middle Left

HAIRLINE CRACKING ONLY:  YES  NO

CRACKS GREATER THAN 1/8" THICK:  YES  NO

Notes (typical Length): 15 FT

CRACKS W/ EFFLORESCENCE:  YES  NO (if yes, circle one) Min. 1  2  3  4  5

Notes: \_\_\_\_\_

REBAR/STRANDING VISIBLE:  YES  NO

Notes: \_\_\_\_\_

NOTICEABLE RUST STAINING: YES  NO

Notes: \_\_\_\_\_

ADDITIONAL DAMAGE TO POLE: YES  NO

Notes: \_\_\_\_\_

ADDITIONAL COMMENTS:

\_\_\_\_\_  
\_\_\_\_\_  
\_\_\_\_\_

**CONCRETE POLE INSPECTION FORM**

INSPECTOR'S INITIALS DS YEAR OF POLE 2019 DATE OF INSPECTION 7/11/19

LINE NUMBER 2007 STR. NUMBER 54 POLE POSITION Right Middle Left

**HAIRLINE CRACKING ONLY:**

YES  NO

**CRACKS GREATER THAN 1/8" THICK:**

YES  NO

Notes (typical Length): \_\_\_\_\_

\_\_\_\_\_

**CRACKS W/ EFFLORESCENCE:**

YES  NO (if yes, circle one) Min. 1  2  3  4  5

Notes: \_\_\_\_\_

\_\_\_\_\_

**REBAR/STRANDING VISIBLE:**

YES  NO

Notes: \_\_\_\_\_

\_\_\_\_\_

**NOTICEABLE RUST STAINING:**

YES  NO

Notes: \_\_\_\_\_

\_\_\_\_\_

**ADDITIONAL DAMAGE TO POLE:**

YES  NO

Notes: \_\_\_\_\_

\_\_\_\_\_

**ADDITIONAL COMMENTS:**

\_\_\_\_\_  
\_\_\_\_\_  
\_\_\_\_\_

**CONCRETE POLE INSPECTION FORM**

INSPECTOR'S INITIALS JS YEAR OF POLE 170 DATE OF INSPECTION 7/11/19

LINE NUMBER 2007 STR. NUMBER 55 POLE POSITION Right Middle Left

HAIRLINE CRACKING ONLY:  YES  NO

CRACKS GREATER THAN 1/8" THICK:  YES  NO

Notes (typical Length): 4-8 FT

CRACKS W/ EFFLORESCENCE:  YES  NO (if yes, circle one) Min. 1 2 3 4 5

Notes: \_\_\_\_\_

REBAR/STRANDING VISIBLE:  YES  NO

Notes: \_\_\_\_\_

NOTICEABLE RUST STAINING: YES  NO

Notes: \_\_\_\_\_

ADDITIONAL DAMAGE TO POLE: YES  NO

Notes: \_\_\_\_\_

ADDITIONAL COMMENTS:  
\_\_\_\_\_  
\_\_\_\_\_  
\_\_\_\_\_

**CONCRETE POLE INSPECTION FORM**

INSPECTOR'S INITIALS BS YEAR OF POLE N/A DATE OF INSPECTION 7/11/19

LINE NUMBER 2007 STR. NUMBER 56 POLE POSITION Right Middle Left

HAIRLINE CRACKING ONLY:  YES  NO

CRACKS GREATER THAN 1/8" THICK:  YES  NO

Notes (typical Length): 10 FT

CRACKS W/ EFFLORESCENCE:  YES  NO (if yes, circle one) Min. 1  2  3  4  5

Notes:

REBAR/STRANDING VISIBLE:  YES  NO

Notes:

NOTICEABLE RUST STAINING: YES  NO

Notes:

ADDITIONAL DAMAGE TO POLE: YES  NO

Notes:

ADDITIONAL COMMENTS:

\_\_\_\_\_  
\_\_\_\_\_  
\_\_\_\_\_

**CONCRETE POLE INSPECTION FORM**

INSPECTOR'S INITIALS JS YEAR OF POLE N/A DATE OF INSPECTION 7/11/19

LINE NUMBER 20037 STR. NUMBER 51 POLE POSITION Right Middle Left

HAIRLINE CRACKING ONLY: YES  NO

CRACKS GREATER THAN 1/8" THICK: YES  NO

Notes (typical Length): \_\_\_\_\_

CRACKS W/ EFFLORESCENCE: YES  NO  (if yes, circle one) Min. 1  2  3  4  5

Notes: \_\_\_\_\_

REBAR/STRANDING VISIBLE: YES  NO

Notes: \_\_\_\_\_

NOTICEABLE RUST STAINING: YES  NO

Notes: \_\_\_\_\_

ADDITIONAL DAMAGE TO POLE: YES  NO

Notes: \_\_\_\_\_

ADDITIONAL COMMENTS:  
\_\_\_\_\_  
\_\_\_\_\_  
\_\_\_\_\_

**CONCRETE POLE INSPECTION FORM**

INSPECTOR'S INITIALS JS YEAR OF POLE N/A DATE OF INSPECTION 7/11/19

LINE NUMBER 2007 STR. NUMBER 58 POLE POSITION Right Middle Left

HAIRLINE CRACKING ONLY:  YES  NO

CRACKS GREATER THAN 1/8" THICK:  YES  NO

Notes (typical Length): 5-10 Ft

CRACKS W/ EFFLORESCENCE:  YES  NO (if yes, circle one) Min. 1 2 3 4 5

Notes:

REBAR/STRANDING VISIBLE: YES  NO

Notes:

NOTICEABLE RUST STAINING:  YES  NO

Notes:

ADDITIONAL DAMAGE TO POLE:  YES  NO

Notes:

ADDITIONAL COMMENTS:

\_\_\_\_\_  
\_\_\_\_\_  
\_\_\_\_\_

**CONCRETE POLE INSPECTION FORM**

INSPECTOR'S INITIALS SS YEAR OF POLE 8/28 DATE OF INSPECTION 7/11/19

LINE NUMBER 2007 STR. NUMBER 59 POLE POSITION Right Middle Left

HAIRLINE CRACKING ONLY:  YES  NO

CRACKS GREATER THAN 1/8" THICK:  YES  NO

Notes (typical Length): 5ft

CRACKS W/ EFFLORESCENCE:  YES  NO (if yes, circle one) Min. 1 2 3 4 5

Notes:

REBAR/STRANDING VISIBLE:  YES  NO

Notes:

NOTICEABLE RUST STAINING: YES  NO

Notes:

ADDITIONAL DAMAGE TO POLE: YES  NO

Notes:

ADDITIONAL COMMENTS:  
\_\_\_\_\_  
\_\_\_\_\_  
\_\_\_\_\_

**CONCRETE POLE INSPECTION FORM**

INSPECTOR'S INITIALS JS YEAR OF POLE 12/69 DATE OF INSPECTION 7/11/19

LINE NUMBER 2007 STR. NUMBER 100 POLE POSITION Right Middle Left

HAIRLINE CRACKING ONLY:  YES  NO

CRACKS GREATER THAN 1/8" THICK: YES  NO

Notes (typical Length): \_\_\_\_\_  
\_\_\_\_\_

CRACKS W/ EFFLORESCENCE:  YES  NO (if yes, circle one) Min. 1  2  3  4  5

Notes: \_\_\_\_\_  
\_\_\_\_\_

REBAR/STRANDING VISIBLE:  YES  NO

Notes: \_\_\_\_\_  
\_\_\_\_\_

NOTICEABLE RUST STAINING: YES  NO

Notes: \_\_\_\_\_  
\_\_\_\_\_

ADDITIONAL DAMAGE TO POLE: YES  NO

Notes: \_\_\_\_\_  
\_\_\_\_\_

ADDITIONAL COMMENTS:

\_\_\_\_\_  
\_\_\_\_\_  
\_\_\_\_\_

**CONCRETE POLE INSPECTION FORM**

INSPECTOR'S INITIALS ES YEAR OF POLE 10/169 DATE OF INSPECTION 7/11/19

LINE NUMBER 2007 STR. NUMBER 61 POLE POSITION Right Middle Left

HAIRLINE CRACKING ONLY:  YES  NO

CRACKS GREATER THAN 1/8" THICK:  YES  NO

Notes (typical Length): 10ft

CRACKS W/ EFFLORESCENCE:  YES  NO (if yes, circle one) Min. 1 2 3 4 5

Notes: \_\_\_\_\_

REBAR/STRANDING VISIBLE:  YES  NO

Notes: \_\_\_\_\_

NOTICEABLE RUST STAINING: YES  NO

Notes: \_\_\_\_\_

ADDITIONAL DAMAGE TO POLE: YES  NO

Notes: \_\_\_\_\_

ADDITIONAL COMMENTS:

\_\_\_\_\_  
\_\_\_\_\_  
\_\_\_\_\_

CONCRETE POLE INSPECTION FORM

INSPECTOR'S INITIALS JS YEAR OF POLE 10/19 DATE OF INSPECTION 7/11/19

LINE NUMBER 2007 STR. NUMBER 62 POLE POSITION Right Middle Left

HAIRLINE CRACKING ONLY:  YES  NO

CRACKS GREATER THAN 1/8" THICK:  YES  NO

Notes (typical Length): 20 Ft

CRACKS W/ EFFLORESCENCE:  YES  NO (if yes, circle one) Min. 1 2 3 4 5

Notes:

REBAR/STRANDING VISIBLE:  YES  NO

Notes:

NOTICEABLE RUST STAINING: YES  NO

Notes:

ADDITIONAL DAMAGE TO POLE: YES  NO

Notes:

ADDITIONAL COMMENTS:

Broken Ground & Broken Insulator

**CONCRETE POLE INSPECTION FORM**

INSPECTOR'S INITIALS JS YEAR OF POLE 12/10 DATE OF INSPECTION 7/11/19

LINE NUMBER 2007 STR. NUMBER 63 POLE POSITION Right Middle Left

**HAIRLINE CRACKING ONLY:**

YES  NO

**CRACKS GREATER THAN 1/8" THICK:**

YES  NO

Notes (typical Length): \_\_\_\_\_  
\_\_\_\_\_

**CRACKS W/ EFFLORESCENCE:**

YES  NO (if yes, circle one) Min. 1  2  3  4  5

Notes: \_\_\_\_\_  
\_\_\_\_\_

**REBAR/STRANDING VISIBLE:**

YES  NO

Notes: \_\_\_\_\_  
\_\_\_\_\_

**NOTICEABLE RUST STAINING:**

YES  NO

Notes: \_\_\_\_\_  
\_\_\_\_\_

**ADDITIONAL DAMAGE TO POLE:**

YES  NO

Notes: \_\_\_\_\_  
\_\_\_\_\_

**ADDITIONAL COMMENTS:**

\_\_\_\_\_  
\_\_\_\_\_  
\_\_\_\_\_

**CONCRETE POLE INSPECTION FORM**

INSPECTOR'S INITIALS DS YEAR OF POLE 11A DATE OF INSPECTION 7/11/19

LINE NUMBER 2007 STR. NUMBER 64 POLE POSITION Right Middle Left

HAIRLINE CRACKING ONLY:  YES  NO

CRACKS GREATER THAN 1/8" THICK:  YES  NO

Notes (typical Length): 5 FT

CRACKS W/ EFFLORESCENCE:  YES  NO (if yes, circle one) Min. 1 2 3 4 5

Notes:

REBAR/STRANDING VISIBLE: YES  NO

Notes:

NOTICEABLE RUST STAINING: YES  NO

Notes:

ADDITIONAL DAMAGE TO POLE: YES  NO

Notes:

ADDITIONAL COMMENTS:

\_\_\_\_\_  
\_\_\_\_\_  
\_\_\_\_\_

**CONCRETE POLE INSPECTION FORM**

INSPECTOR'S INITIALS JB YEAR OF POLE 01A DATE OF INSPECTION 7/11/19

LINE NUMBER 2007 STR. NUMBER 105 POLE POSITION Right Middle Left

**HAIRLINE CRACKING ONLY:**

YES  NO

**CRACKS GREATER THAN 1/8" THICK:**

YES  NO

Notes (typical Length): \_\_\_\_\_

**CRACKS W/ EFFLORESCENCE:**

YES  NO (if yes, circle one) Min. 1 2  3 4 5

Notes: \_\_\_\_\_

**REBAR/STRANDING VISIBLE:**

YES  NO

Notes: \_\_\_\_\_

**NOTICEABLE RUST STAINING:**

YES  NO

Notes: \_\_\_\_\_

**ADDITIONAL DAMAGE TO POLE:**

YES  NO

Notes: \_\_\_\_\_

**ADDITIONAL COMMENTS:**

\_\_\_\_\_  
\_\_\_\_\_  
\_\_\_\_\_

CONCRETE POLE INSPECTION FORM

INSPECTOR'S INITIALS BJ YEAR OF POLE 9/10<sup>No year</sup> DATE OF INSPECTION 7/11/19

LINE NUMBER 2007 STR. NUMBER 66 POLE POSITION Right Middle Left

HAIRLINE CRACKING ONLY: YES  NO

CRACKS GREATER THAN 1/8" THICK: YES  NO

Notes (typical Length): 11'

CRACKS W/ EFFLORESCENCE: YES  NO  (if yes, circle one) Min. 1 2  4 5

Notes:

REBAR/STRANDING VISIBLE: YES  NO

Notes:

NOTICEABLE RUST STAINING: YES  NO

Notes:

ADDITIONAL DAMAGE TO POLE: YES  NO

Notes:

ADDITIONAL COMMENTS:

\_\_\_\_\_  
\_\_\_\_\_  
\_\_\_\_\_

CONCRETE POLE INSPECTION FORM

INSPECTOR'S INITIALS Bd. YEAR OF POLE 1969 DATE OF INSPECTION 7/11/19

LINE NUMBER 2007 STR. NUMBER 67 POLE POSITION  Right  Middle  Left

HAIRLINE CRACKING ONLY: YES  NO

CRACKS GREATER THAN 1/8" THICK: YES  NO

Notes (typical Length): 6'

CRACKS W/ EFFLORESCENCE: YES  NO  (if yes, circle one) Min.  1  2  3  4  5

Notes:

REBAR/STRANDING VISIBLE: YES  NO

Notes:

NOTICEABLE RUST STAINING: YES  NO

Notes:

ADDITIONAL DAMAGE TO POLE: YES  NO

Notes:

ADDITIONAL COMMENTS:

\_\_\_\_\_  
\_\_\_\_\_  
\_\_\_\_\_

CONCRETE POLE INSPECTION FORM

INSPECTOR'S INITIALS B.J. YEAR OF POLE 8/18 <sup>No year</sup> DATE OF INSPECTION 7/11/19

LINE NUMBER 2007 STR. NUMBER 68 POLE POSITION Right Middle Left

HAIRLINE CRACKING ONLY: YES  NO

CRACKS GREATER THAN 1/8" THICK: YES  NO

Notes (typical Length): 15'

CRACKS W/ EFFLORESCENCE: YES  NO  (if yes, circle one) Min. 1 2 3 4 5

Notes: \_\_\_\_\_

REBAR/STRANDING VISIBLE: YES  NO

Notes: \_\_\_\_\_

NOTICEABLE RUST STAINING: YES  NO

Notes: \_\_\_\_\_

ADDITIONAL DAMAGE TO POLE: YES  NO

Notes: \_\_\_\_\_

ADDITIONAL COMMENTS:  
\_\_\_\_\_  
\_\_\_\_\_  
\_\_\_\_\_

CONCRETE POLE INSPECTION FORM

INSPECTOR'S INITIALS B2 YEAR OF POLE TagWorn DATE OF INSPECTION 7/1/19

LINE NUMBER 2007 STR. NUMBER 69 POLE POSITION Right Middle Left

HAIRLINE CRACKING ONLY: YES  NO

CRACKS GREATER THAN 1/8" THICK: YES  NO

Notes (typical Length): 20'

CRACKS W/ EFFLORESCENCE: YES  NO  (if yes, circle one) Min. 1 2 3 4 5

Notes:

REBAR/STRANDING VISIBLE: YES  NO

Notes:

NOTICEABLE RUST STAINING: YES  NO

Notes:

ADDITIONAL DAMAGE TO POLE: YES  NO

Notes:

ADDITIONAL COMMENTS:

\_\_\_\_\_  
\_\_\_\_\_  
\_\_\_\_\_

CONCRETE POLE INSPECTION FORM

INSPECTOR'S INITIALS BL YEAR OF POLE Tag 2007 DATE OF INSPECTION 7/11/19

LINE NUMBER 2007 STR. NUMBER 70 POLE POSITION Right Middle Left

HAIRLINE CRACKING ONLY: YES  NO

CRACKS GREATER THAN 1/8" THICK: YES  NO

Notes (typical Length): 14'

CRACKS W/ EFFLORESCENCE: YES  NO  (if yes, circle one) Min. 1 2 3 4 5

Notes: \_\_\_\_\_

REBAR/STRANDING VISIBLE: YES  NO

Notes: \_\_\_\_\_

NOTICEABLE RUST STAINING: YES  NO

Notes: \_\_\_\_\_

ADDITIONAL DAMAGE TO POLE: YES  NO

Notes: \_\_\_\_\_

ADDITIONAL COMMENTS:  
\_\_\_\_\_  
\_\_\_\_\_  
\_\_\_\_\_

CONCRETE POLE INSPECTION FORM

INSPECTOR'S INITIALS Bd YEAR OF POLE 1969 DATE OF INSPECTION 7/10/19

LINE NUMBER 2007 STR. NUMBER 71 POLE POSITION Right Middle Left

HAIRLINE CRACKING ONLY: YES  NO

CRACKS GREATER THAN 1/8" THICK: YES  NO

Notes (typical Length): 8'

CRACKS W/ EFFLORESCENCE: YES  NO  (if yes, circle one) Min. 1 2 3 4 5

Notes:

REBAR/STRANDING VISIBLE: YES  NO

Notes: Between middle and bottom phase arms

NOTICEABLE RUST STAINING: YES  NO

Notes:

ADDITIONAL DAMAGE TO POLE: YES  NO

Notes:

ADDITIONAL COMMENTS:

\_\_\_\_\_  
\_\_\_\_\_  
\_\_\_\_\_

CONCRETE POLE INSPECTION FORM

INSPECTOR'S INITIALS BSJ YEAR OF POLE 1969 DATE OF INSPECTION 7/1/19

LINE NUMBER 2007 STR. NUMBER 72 POLE POSITION Right Middle Left

HAIRLINE CRACKING ONLY: YES  NO

CRACKS GREATER THAN 1/8" THICK:  YES NO

Notes (typical Length): 8'

CRACKS W/ EFFLORESCENCE:  YES NO (if yes, circle one) Min. 1 2 3 4  5

Notes:

REBAR/STRANDING VISIBLE:  YES NO

Notes: 10' at bottom phase arm

NOTICEABLE RUST STAINING: YES  NO

Notes:

ADDITIONAL DAMAGE TO POLE: YES  NO

Notes:

ADDITIONAL COMMENTS:

\_\_\_\_\_  
\_\_\_\_\_  
\_\_\_\_\_

CONCRETE POLE INSPECTION FORM

INSPECTOR'S INITIALS BS YEAR OF POLE Tag worn DATE OF INSPECTION 7/11/19

LINE NUMBER 2007 STR. NUMBER 73 POLE POSITION Right Middle Left

HAIRLINE CRACKING ONLY: YES  NO

CRACKS GREATER THAN 1/8" THICK: YES  NO

Notes (typical Length): 9'

CRACKS W/ EFFLORESCENCE: YES  NO  (if yes, circle one) Min. 1 2 3 4 5

Notes:

REBAR/STRANDING VISIBLE: YES  NO

Notes:

NOTICEABLE RUST STAINING: YES  NO

Notes:

ADDITIONAL DAMAGE TO POLE: YES  NO

Notes:

ADDITIONAL COMMENTS:  
\_\_\_\_\_  
\_\_\_\_\_  
\_\_\_\_\_

CONCRETE POLE INSPECTION FORM

INSPECTOR'S INITIALS BS YEAR OF POLE 1970 DATE OF INSPECTION 7/1/19

LINE NUMBER 2007 STR. NUMBER 74 POLE POSITION Right Middle Left

HAIRLINE CRACKING ONLY: YES  NO

CRACKS GREATER THAN 1/8" THICK: YES  NO

Notes (typical Length): 15'

CRACKS W/ EFFLORESCENCE: YES  NO  (if yes, circle one) Min. 1 2 3 4 5

Notes:

REBAR/STRANDING VISIBLE: YES  NO

Notes:

NOTICEABLE RUST STAINING: YES  NO

Notes:

ADDITIONAL DAMAGE TO POLE: YES  NO

Notes:

ADDITIONAL COMMENTS:

\_\_\_\_\_  
\_\_\_\_\_  
\_\_\_\_\_

CONCRETE POLE INSPECTION FORM

INSPECTOR'S INITIALS Bd YEAR OF POLE 1969 DATE OF INSPECTION 7/11/19

LINE NUMBER 2007 STR. NUMBER 75 POLE POSITION Right Middle Left

HAIRLINE CRACKING ONLY: YES  NO

CRACKS GREATER THAN 1/8" THICK: YES  NO

Notes (typical Length): 13'

CRACKS W/ EFFLORESCENCE: YES  NO  (if yes, circle one) Min. 1 2  4 5

Notes: \_\_\_\_\_

REBAR/STRANDING VISIBLE: YES  NO

Notes: Between bottom and middle phase arms

NOTICEABLE RUST STAINING: YES  NO

Notes: \_\_\_\_\_

ADDITIONAL DAMAGE TO POLE: YES  NO

Notes: \_\_\_\_\_

ADDITIONAL COMMENTS:

\_\_\_\_\_  
\_\_\_\_\_  
\_\_\_\_\_

CONCRETE POLE INSPECTION FORM

INSPECTOR'S INITIALS BL YEAR OF POLE 1970 DATE OF INSPECTION 7/11/19

LINE NUMBER 2007 STR. NUMBER 76 POLE POSITION Right Middle Left

HAIRLINE CRACKING ONLY: YES  NO

CRACKS GREATER THAN 1/8" THICK: YES  NO

Notes (typical Length): 11'

CRACKS W/ EFFLORESCENCE: YES  NO  (if yes, circle one) Min. 1 2 3 4 5

Notes:

REBAR/STRANDING VISIBLE: YES  NO

Notes:

NOTICEABLE RUST STAINING: YES  NO

Notes:

ADDITIONAL DAMAGE TO POLE: YES  NO

Notes:

ADDITIONAL COMMENTS:  
\_\_\_\_\_  
\_\_\_\_\_  
\_\_\_\_\_

CONCRETE POLE INSPECTION FORM

INSPECTOR'S INITIALS BS YEAR OF POLE Tag Wood DATE OF INSPECTION 7/11/19  
LINE NUMBER 2007 STR. NUMBER 77 POLE POSITION Right Middle Left

HAIRLINE CRACKING ONLY: YES  NO

CRACKS GREATER THAN 1/8" THICK: YES  NO

Notes (typical Length): 10'

CRACKS W/ EFFLORESCENCE: YES  NO  (if yes, circle one) Min. 1  2  3  4  5

Notes:

REBAR/STRANDING VISIBLE: YES  NO

Notes:

NOTICEABLE RUST STAINING: YES  NO

Notes:

ADDITIONAL DAMAGE TO POLE: YES  NO

Notes:

ADDITIONAL COMMENTS:

\_\_\_\_\_  
\_\_\_\_\_  
\_\_\_\_\_

CONCRETE POLE INSPECTION FORM

INSPECTOR'S INITIALS Bd YEAR OF POLE 1969 DATE OF INSPECTION 7/11/19

LINE NUMBER 2007 STR. NUMBER 78 POLE POSITION Right Middle Left

HAIRLINE CRACKING ONLY: YES  NO

CRACKS GREATER THAN 1/8" THICK: YES  NO

Notes (typical Length): 12'

CRACKS W/ EFFLORESCENCE: YES  NO  (if yes, circle one) Min. 1 2 3 4 5

Notes:

REBAR/STRANDING VISIBLE: YES  NO

Notes:

NOTICEABLE RUST STAINING: YES  NO

Notes:

ADDITIONAL DAMAGE TO POLE: YES  NO

Notes:

ADDITIONAL COMMENTS:  
\_\_\_\_\_  
\_\_\_\_\_  
\_\_\_\_\_

CONCRETE POLE INSPECTION FORM

INSPECTOR'S INITIALS BZ YEAR OF POLE 1969 DATE OF INSPECTION 7/11/19

LINE NUMBER 2007 STR. NUMBER 79 POLE POSITION Right Middle Left

HAIRLINE CRACKING ONLY: YES  NO

CRACKS GREATER THAN 1/8" THICK: YES  NO

Notes (typical Length): 20'

CRACKS W/ EFFLORESCENCE: YES  NO  (if yes, circle one) Min. 1 2 3 4 5

Notes:

REBAR/STRANDING VISIBLE: YES  NO

Notes:

NOTICEABLE RUST STAINING: YES  NO

Notes:

ADDITIONAL DAMAGE TO POLE: YES  NO

Notes:

ADDITIONAL COMMENTS:  
\_\_\_\_\_  
\_\_\_\_\_  
\_\_\_\_\_

CONCRETE POLE INSPECTION FORM

INSPECTOR'S INITIALS BJ YEAR OF POLE TagWorn DATE OF INSPECTION 2/11/19

LINE NUMBER 2007 STR. NUMBER 80 POLE POSITION Right Middle Left

HAIRLINE CRACKING ONLY: YES  NO

CRACKS GREATER THAN 1/8" THICK: YES  NO

Notes (typical Length): 4'

CRACKS W/ EFFLORESCENCE: YES  NO  (if yes, circle one) Min. 1  2  3  4  5

Notes:

REBAR/STRANDING VISIBLE: YES  NO

Notes:

NOTICEABLE RUST STAINING: YES  NO

Notes:

ADDITIONAL DAMAGE TO POLE: YES  NO

Notes:

ADDITIONAL COMMENTS:

\_\_\_\_\_  
\_\_\_\_\_  
\_\_\_\_\_

CONCRETE POLE INSPECTION FORM

INSPECTOR'S INITIALS BZ YEAR OF POLE 1969 DATE OF INSPECTION 7/11/19

LINE NUMBER 2007 STR. NUMBER 81 POLE POSITION Right Middle Left

HAIRLINE CRACKING ONLY: YES  NO

CRACKS GREATER THAN 1/8" THICK: YES  NO

Notes (typical Length): 4'

CRACKS W/ EFFLORESCENCE: YES  NO  (if yes, circle one) Min. 1  2  3  4  5

Notes:

REBAR/STRANDING VISIBLE: YES  NO

Notes:

NOTICEABLE RUST STAINING: YES  NO

Notes:

ADDITIONAL DAMAGE TO POLE: YES  NO

Notes: Botto

ADDITIONAL COMMENTS:

Bottom phase arm rust showing.

CONCRETE POLE INSPECTION FORM

INSPECTOR'S INITIALS Bj YEAR OF POLE Taghborn DATE OF INSPECTION 7/11/19

LINE NUMBER 2007 STR. NUMBER 82 POLE POSITION Right Middle Left

HAIRLINE CRACKING ONLY: YES  NO

CRACKS GREATER THAN 1/8" THICK: YES  NO

Notes (typical Length): 10'

CRACKS W/ EFFLORESCENCE: YES  NO  (if yes, circle one) Min. 1 2 3 4 5

Notes:

REBAR/STRANDING VISIBLE: YES  NO

Notes:

NOTICEABLE RUST STAINING: YES  NO

Notes:

ADDITIONAL DAMAGE TO POLE: YES  NO

Notes:

ADDITIONAL COMMENTS:

\_\_\_\_\_  
\_\_\_\_\_  
\_\_\_\_\_

CONCRETE POLE INSPECTION FORM

INSPECTOR'S INITIALS BS YEAR OF POLE 1969 DATE OF INSPECTION 7/11/19

LINE NUMBER 2007 STR. NUMBER 83 POLE POSITION Right Middle Left

HAIRLINE CRACKING ONLY: YES  NO

CRACKS GREATER THAN 1/8" THICK: YES  NO

Notes (typical Length): 4'

CRACKS W/ EFFLORESCENCE: YES  NO  (if yes, circle one) Min. 1  2  3  4  5

Notes:

REBAR/STRANDING VISIBLE: YES  NO

Notes:

NOTICEABLE RUST STAINING: YES  NO

Notes:

ADDITIONAL DAMAGE TO POLE: YES  NO

Notes:

ADDITIONAL COMMENTS:  
\_\_\_\_\_  
\_\_\_\_\_  
\_\_\_\_\_

CONCRETE POLE INSPECTION FORM

INSPECTOR'S INITIALS BJ YEAR OF POLE 8/26 <sup>106 Year</sup> DATE OF INSPECTION 7/11/19

LINE NUMBER 2007 STR. NUMBER 84 POLE POSITION Right Middle Left

HAIRLINE CRACKING ONLY: YES  NO

CRACKS GREATER THAN 1/8" THICK:  YES NO

Notes (typical Length): 5'

CRACKS W/ EFFLORESCENCE:  YES NO (if yes, circle one) Min. 1 2 3  4 5

Notes: \_\_\_\_\_

REBAR/STRANDING VISIBLE: YES  NO

Notes: \_\_\_\_\_

NOTICEABLE RUST STAINING:  YES NO

Notes: \_\_\_\_\_

ADDITIONAL DAMAGE TO POLE: YES  NO

Notes: \_\_\_\_\_

ADDITIONAL COMMENTS:  
\_\_\_\_\_  
\_\_\_\_\_  
\_\_\_\_\_

CONCRETE POLE INSPECTION FORM

INSPECTOR'S INITIALS BZ YEAR OF POLE 1969 DATE OF INSPECTION 7/11/19

LINE NUMBER 2007 STR. NUMBER 85 POLE POSITION Right Middle Left

HAIRLINE CRACKING ONLY:

YES  NO

CRACKS GREATER THAN 1/8" THICK:

YES NO

Notes (typical Length): 2'

CRACKS W/ EFFLORESCENCE:

YES NO (if yes, circle one) Min.  1  2  3  4  5

Notes:

REBAR/STRANDING VISIBLE:

YES  NO

Notes:

NOTICEABLE RUST STAINING:

YES NO

Notes:

ADDITIONAL DAMAGE TO POLE:

YES  NO

Notes:

ADDITIONAL COMMENTS:

CONCRETE POLE INSPECTION FORM

INSPECTOR'S INITIALS BZ YEAR OF POLE 1969 DATE OF INSPECTION 7/11/19

LINE NUMBER 2007 STR. NUMBER 86 POLE POSITION Right Middle Left

HAIRLINE CRACKING ONLY:

YES  NO

CRACKS GREATER THAN 1/8" THICK:

YES  NO

Notes (typical Length): 7'

CRACKS W/ EFFLORESCENCE:

YES  NO  (if yes, circle one) Min. 1  2  3  4  5

Notes:

REBAR/STRANDING VISIBLE:

YES  NO

Notes:

NOTICEABLE RUST STAINING:

YES  NO

Notes:

ADDITIONAL DAMAGE TO POLE:

YES  NO

Notes:

ADDITIONAL COMMENTS:

\_\_\_\_\_  
\_\_\_\_\_  
\_\_\_\_\_

CONCRETE POLE INSPECTION FORM

INSPECTOR'S INITIALS BZ YEAR OF POLE 1969 DATE OF INSPECTION 7/9/19

LINE NUMBER 2007 STR. NUMBER 87 POLE POSITION Right Middle Left

HAIRLINE CRACKING ONLY:  YES  NO

CRACKS GREATER THAN 1/8" THICK: YES  NO

Notes (typical Length): 3'

CRACKS W/ EFFLORESCENCE:  YES  NO (if yes, circle one) Min. 1 2  3 4 5

Notes: \_\_\_\_\_

REBAR/STRANDING VISIBLE: YES  NO

Notes: \_\_\_\_\_

NOTICEABLE RUST STAINING:  YES  NO

Notes: Approx 12" showing between bottom and middle phases

ADDITIONAL DAMAGE TO POLE: YES  NO

Notes: \_\_\_\_\_

ADDITIONAL COMMENTS:

\_\_\_\_\_  
\_\_\_\_\_  
\_\_\_\_\_

CONCRETE POLE INSPECTION FORM

INSPECTOR'S INITIALS BJ YEAR OF POLE Tag Worn N/A DATE OF INSPECTION 7/9/19

LINE NUMBER 2007 STR. NUMBER 88 POLE POSITION Right Middle Left

HAIRLINE CRACKING ONLY: YES  NO

CRACKS GREATER THAN 1/8" THICK: YES  NO

Notes (typical Length): 5'

CRACKS W/ EFFLORESCENCE: YES  NO  (if yes, circle one) Min.  1  2  3  4  5

Notes:

REBAR/STRANDING VISIBLE: YES  NO

Notes:

NOTICEABLE RUST STAINING: YES  NO

Notes:

ADDITIONAL DAMAGE TO POLE: YES  NO

Notes:

ADDITIONAL COMMENTS:

\_\_\_\_\_  
\_\_\_\_\_  
\_\_\_\_\_

CONCRETE POLE INSPECTION FORM

INSPECTOR'S INITIALS Bd YEAR OF POLE <sup>Tag Worn</sup> N/A DATE OF INSPECTION 7/9/19

LINE NUMBER 2007 STR. NUMBER 89 POLE POSITION Right Middle Left

HAIRLINE CRACKING ONLY: YES  NO

CRACKS GREATER THAN 1/8" THICK: YES  NO

Notes (typical Length): 4'

CRACKS W/ EFFLORESCENCE: YES  NO  (if yes, circle one) Min. 1  2  3  4  5

Notes:

REBAR/STRANDING VISIBLE: YES  NO

Notes:

NOTICEABLE RUST STAINING: YES  NO

Notes:

ADDITIONAL DAMAGE TO POLE: YES  NO

Notes:

ADDITIONAL COMMENTS:

\_\_\_\_\_  
\_\_\_\_\_  
\_\_\_\_\_

CONCRETE POLE INSPECTION FORM

INSPECTOR'S INITIALS BZ YEAR OF POLE <sup>Tag worn</sup> N/A DATE OF INSPECTION 7/9/19

LINE NUMBER 2007 STR. NUMBER 90 POLE POSITION Right Middle Left

HAIRLINE CRACKING ONLY: YES  NO

CRACKS GREATER THAN 1/8" THICK: YES  NO

Notes (typical Length): 6'

CRACKS W/ EFFLORESCENCE: YES  NO  (if yes, circle one) Min. 1  2  3  4  5

Notes: \_\_\_\_\_

REBAR/STRANDING VISIBLE: YES  NO

Notes: \_\_\_\_\_

NOTICEABLE RUST STAINING: YES  NO

Notes: \_\_\_\_\_

ADDITIONAL DAMAGE TO POLE: YES  NO

Notes: \_\_\_\_\_

ADDITIONAL COMMENTS:  
\_\_\_\_\_  
\_\_\_\_\_  
\_\_\_\_\_

CONCRETE POLE INSPECTION FORM

INSPECTOR'S INITIALS BZ YEAR OF POLE <sup>Tag worn</sup> N/A DATE OF INSPECTION 7/9/19

LINE NUMBER 2007 STR. NUMBER 91 POLE POSITION Right Middle Left

HAIRLINE CRACKING ONLY: YES  NO

CRACKS GREATER THAN 1/8" THICK: YES  NO

Notes (typical Length): 10'

CRACKS W/ EFFLORESCENCE: YES  NO  (if yes, circle one) Min. 1 2 3 4 5

Notes: \_\_\_\_\_

REBAR/STRANDING VISIBLE: YES  NO

Notes: \_\_\_\_\_

NOTICEABLE RUST STAINING: YES  NO

Notes: \_\_\_\_\_

ADDITIONAL DAMAGE TO POLE: YES  NO

Notes: \_\_\_\_\_

ADDITIONAL COMMENTS:  
\_\_\_\_\_  
\_\_\_\_\_  
\_\_\_\_\_

CONCRETE POLE INSPECTION FORM

INSPECTOR'S INITIALS B2 YEAR OF POLE <sup>Tag Warn</sup> N/A DATE OF INSPECTION 7/9/19

LINE NUMBER 2007 STR. NUMBER 92 POLE POSITION Right Middle Left

HAIRLINE CRACKING ONLY: YES  NO

CRACKS GREATER THAN 1/8" THICK: YES  NO

Notes (typical Length): 13'

CRACKS W/ EFFLORESCENCE: YES  NO  (if yes, circle one) Min. 1 2  4  5

Notes:

REBAR/STRANDING VISIBLE: YES  NO

Notes:

NOTICEABLE RUST STAINING: YES  NO

Notes:

ADDITIONAL DAMAGE TO POLE: YES  NO

Notes:

ADDITIONAL COMMENTS:

\_\_\_\_\_  
\_\_\_\_\_  
\_\_\_\_\_

CONCRETE POLE INSPECTION FORM

INSPECTOR'S INITIALS BP YEAR OF POLE Tag Warn DATE OF INSPECTION 7/9/19

LINE NUMBER 2007 STR. NUMBER 93 POLE POSITION Right Middle Left

HAIRLINE CRACKING ONLY: YES  NO

CRACKS GREATER THAN 1/8" THICK: YES  NO

Notes (typical Length): 6'

CRACKS W/ EFFLORESCENCE: YES  NO  (if yes, circle one) Min.  2  3  4  5

Notes:

REBAR/STRANDING VISIBLE: YES  NO

Notes:

NOTICEABLE RUST STAINING: YES  NO

Notes:

ADDITIONAL DAMAGE TO POLE: YES  NO

Notes:

ADDITIONAL COMMENTS:

\_\_\_\_\_  
\_\_\_\_\_  
\_\_\_\_\_

CONCRETE POLE INSPECTION FORM

INSPECTOR'S INITIALS B.L. YEAR OF POLE Tag Warn N/A DATE OF INSPECTION 7/9/19

LINE NUMBER 2007 STR. NUMBER 94 POLE POSITION Right Middle Left

HAIRLINE CRACKING ONLY: YES  NO

CRACKS GREATER THAN 1/8" THICK: YES  NO

Notes (typical Length): 12'

CRACKS W/ EFFLORESCENCE: YES  NO  (if yes, circle one) Min. 1 2 3 4 5

Notes: \_\_\_\_\_

REBAR/STRANDING VISIBLE: YES  NO

Notes: \_\_\_\_\_

NOTICEABLE RUST STAINING: YES  NO

Notes: \_\_\_\_\_

ADDITIONAL DAMAGE TO POLE: YES  NO

Notes: \_\_\_\_\_

ADDITIONAL COMMENTS:  
\_\_\_\_\_  
\_\_\_\_\_  
\_\_\_\_\_

CONCRETE POLE INSPECTION FORM

INSPECTOR'S INITIALS BZ YEAR OF POLE Tag Worn DATE OF INSPECTION 7/9/19

LINE NUMBER 2007 STR. NUMBER 95 POLE POSITION Right Middle Left

HAIRLINE CRACKING ONLY: YES  NO

CRACKS GREATER THAN 1/8" THICK: YES  NO

Notes (typical Length): 10'

CRACKS W/ EFFLORESCENCE: YES  NO  (if yes, circle one) Min. 1 2 3 4  5

Notes:

REBAR/STRANDING VISIBLE: YES  NO

Notes:

NOTICEABLE RUST STAINING: YES  NO

Notes:

ADDITIONAL DAMAGE TO POLE: YES  NO

Notes:

ADDITIONAL COMMENTS:

\_\_\_\_\_  
\_\_\_\_\_  
\_\_\_\_\_

CONCRETE POLE INSPECTION FORM

INSPECTOR'S INITIALS BZ YEAR OF POLE 1969 DATE OF INSPECTION 7/9/19

LINE NUMBER 2007 STR. NUMBER 96 POLE POSITION Right Middle Left

HAIRLINE CRACKING ONLY: YES  NO

CRACKS GREATER THAN 1/8" THICK: YES  NO

Notes (typical Length): 14'

CRACKS W/ EFFLORESCENCE: YES  NO  (if yes, circle one) Min. 1 2 3 4 5

Notes:

REBAR/STRANDING VISIBLE: YES  NO

Notes:

NOTICEABLE RUST STAINING: YES  NO

Notes:

ADDITIONAL DAMAGE TO POLE: YES  NO

Notes:

ADDITIONAL COMMENTS:  
\_\_\_\_\_  
\_\_\_\_\_  
\_\_\_\_\_

CONCRETE POLE INSPECTION FORM

INSPECTOR'S INITIALS BZ YEAR OF POLE TagWorn DATE OF INSPECTION 7/9/19

LINE NUMBER 2007 STR. NUMBER 97 POLE POSITION Right Middle Left

HAIRLINE CRACKING ONLY: YES  NO

CRACKS GREATER THAN 1/8" THICK: YES  NO

Notes (typical Length): 8'

CRACKS W/ EFFLORESCENCE: YES  NO  (if yes, circle one) Min. 1 2 3  4 5

Notes:

REBAR/STRANDING VISIBLE: YES  NO

Notes:

NOTICEABLE RUST STAINING: YES  NO

Notes:

ADDITIONAL DAMAGE TO POLE: YES  NO

Notes:

ADDITIONAL COMMENTS:

\_\_\_\_\_  
\_\_\_\_\_  
\_\_\_\_\_

CONCRETE POLE INSPECTION FORM

INSPECTOR'S INITIALS BSJ YEAR OF POLE Ty Worn DATE OF INSPECTION 7/9/19

LINE NUMBER 2007 STR. NUMBER 98 POLE POSITION Right Middle Left

HAIRLINE CRACKING ONLY:

YES  NO

CRACKS GREATER THAN 1/8" THICK:

YES  NO

Notes (typical Length): 6'

CRACKS W/ EFFLORESCENCE:

YES  NO  (if yes, circle one) Min. 1 2 3 4 5

Notes:

REBAR/STRANDING VISIBLE:

YES  NO

Notes:

NOTICEABLE RUST STAINING:

YES  NO

Notes:

ADDITIONAL DAMAGE TO POLE:

YES  NO

Notes:

ADDITIONAL COMMENTS:

\_\_\_\_\_  
\_\_\_\_\_  
\_\_\_\_\_

CONCRETE POLE INSPECTION FORM

INSPECTOR'S INITIALS BS YEAR OF POLE 1970 DATE OF INSPECTION 7/9/19

LINE NUMBER 2007 STR. NUMBER 99 POLE POSITION Right Middle Left

HAIRLINE CRACKING ONLY:

YES  NO

CRACKS GREATER THAN 1/8" THICK:

YES  NO

Notes (typical Length): 8'

CRACKS W/ EFFLORESCENCE:

YES  NO  (if yes, circle one) Min. 1 2 3  4 5

Notes:

REBAR/STRANDING VISIBLE:

YES  NO

Notes:

NOTICEABLE RUST STAINING:

YES  NO

Notes:

ADDITIONAL DAMAGE TO POLE:

YES  NO

Notes:

ADDITIONAL COMMENTS:

\_\_\_\_\_  
\_\_\_\_\_  
\_\_\_\_\_

CONCRETE POLE INSPECTION FORM

INSPECTOR'S INITIALS BZ YEAR OF POLE Tagdown DATE OF INSPECTION 7/9/19

LINE NUMBER 2007 STR. NUMBER 100 POLE POSITION Right Middle Left

HAIRLINE CRACKING ONLY:

YES  NO

CRACKS GREATER THAN 1/8" THICK:

YES  NO

Notes (typical Length): 7'

CRACKS W/ EFFLORESCENCE:

YES  NO  (if yes, circle one) Min. 1 2 3 4 5

Notes:

REBAR/STRANDING VISIBLE:

YES  NO

Notes:

NOTICEABLE RUST STAINING:

YES  NO

Notes:

ADDITIONAL DAMAGE TO POLE:

YES  NO

Notes:

ADDITIONAL COMMENTS:

\_\_\_\_\_  
\_\_\_\_\_  
\_\_\_\_\_

CONCRETE POLE INSPECTION FORM

INSPECTOR'S INITIALS B2 YEAR OF POLE N/A <sup>Tag Worn</sup> DATE OF INSPECTION 7/9/19

LINE NUMBER 2007 STR. NUMBER 101 POLE POSITION Right Middle Left

HAIRLINE CRACKING ONLY: YES  NO

CRACKS GREATER THAN 1/8" THICK: YES  NO

Notes (typical Length): 10'

CRACKS W/ EFFLORESCENCE: YES  NO  (if yes, circle one) Min. 1 2 3 4  5

Notes: \_\_\_\_\_

REBAR/STRANDING VISIBLE: YES  NO

Notes: At base

NOTICEABLE RUST STAINING: YES  NO

Notes: \_\_\_\_\_

ADDITIONAL DAMAGE TO POLE: YES  NO

Notes: \_\_\_\_\_

ADDITIONAL COMMENTS:  
\_\_\_\_\_  
\_\_\_\_\_  
\_\_\_\_\_

CONCRETE POLE INSPECTION FORM

INSPECTOR'S INITIALS Bd YEAR OF POLE 1974 DATE OF INSPECTION 7/9/19

LINE NUMBER 2007 STR. NUMBER 102 POLE POSITION Right Middle Left

HAIRLINE CRACKING ONLY: YES  NO

CRACKS GREATER THAN 1/8" THICK: YES  NO

Notes (typical Length): 12'

CRACKS W/ EFFLORESCENCE: YES  NO  (if yes, circle one) Min. 1 2  4 5

Notes:

REBAR/STRANDING VISIBLE: YES  NO

Notes:

NOTICEABLE RUST STAINING: YES  NO

Notes:

ADDITIONAL DAMAGE TO POLE: YES  NO

Notes:

ADDITIONAL COMMENTS:

\_\_\_\_\_  
\_\_\_\_\_  
\_\_\_\_\_

**I. NECESSITY FOR THE PROPOSED PROJECT**

**M. In addition to the other information required by these guidelines, applications for approval to construct facilities and transmission lines interconnecting a Non-Utility Generator (“NUG”) and a utility shall include the following information:**

- 1. The full name of the NUG as it appears in its contract with the utility and the dates of initial contract and any amendments;**
- 2. A description of the arrangements for financing the facilities, including information on the allocation of costs between the utility and the NUG;**
- 3. a. For Qualifying Facilities (“QFs”) certificated by Federal Energy Regulatory Commission (“FERC”) order, provide the QF or docket number, the dates of all certification or recertification orders, and the citation to FERC Reports, if available;**  
**b. For self-certificated QFs, provide a copy of the notice filed with FERC;**
- 4. Provide the project number and project name used by FERC in licensing hydroelectric projects; also provide the dates of all orders and citations to FERC Reports, if available; and**
- 5. If the name provided in 1 above differs from the name provided in 3 above, give a full explanation.**

Response: Not applicable.

**I. NECESSITY FOR THE PROPOSED PROJECT**

- N. Describe the proposed and existing generating sources, distribution circuits or load centers planned to be served by all new substations, switching stations and other ground facilities associated with the proposed project.**

Response: Not applicable.

## **II. DESCRIPTION OF THE PROPOSED PROJECT**

### **A. Right-of-way (“ROW”)**

#### **1. Provide the length of the proposed corridor and viable alternatives.**

Response: The total length of the Rebuild Project is approximately 4.54 miles from Structure #2019/20 to the Lynnhaven Substation (Structure #2007/104). No alternative routes are proposed for the Rebuild Project. See Section II.A.9 of the Appendix for an explanation of the Company’s route selection process.

## II. DESCRIPTION OF THE PROPOSED PROJECT

### A. Right-of-way (“ROW”)

2. **Provide color maps of suitable scale (including both general location mapping and more detailed GIS-based constraints mapping) showing the route of the proposed line and its relation to: the facilities of other public utilities that could influence the route selection, highways, streets, parks and recreational areas, scenic and historic areas, open space and conservation easements, schools, convalescent centers, churches, hospitals, burial grounds/cemeteries, airports and other notable structures close to the proposed project. Indicate the existing linear utility facilities that the line is proposed to parallel, such as electric transmission lines, natural gas transmission lines, pipelines, highways, and railroads. Indicate any existing transmission ROW sections that are to be quitclaimed or otherwise relinquished. Additionally, identify the manner in which the Applicant will make available to interested persons, including state and local governmental entities, the digital GIS shape file for the route of the proposed line.**

Response: See Attachment II.A.2. The existing transmission line parallels a retired Norfolk Southern railroad, now owned by the City of Virginia Beach, for the length of the Rebuild Project. There are a variety of existing utilities within and parallel to the right-of-way. Water and sewer lines parallel the Rebuild Project from Structure #2019/20 to Structures #2007/80 and #2007/68, respectively, before leaving the right-of-way. No portion of the right-of-way is proposed to be quitclaimed or relinquished.

The Company will make a digital Geographic Information Systems shapefile available to interested persons upon request to counsel for the Company.

ATTACHMENT II.A.2

**ENVIRONMENTAL CONSTRAINTS MAP**

**Lines #2019 and #2007 Rebuild Project**

City of Virginia Beach, Virginia

Owner/Applicant:

Dominion Energy Virginia

Prepared By: GCF

Date: 07/19/22

C2 Env Project: 0233



**LEGEND**

- Existing Line #2019
- Project Centerline
- Existing Line #2007
- Project Centerline
- Existing Structure
- 2019/20
- Existing Substation
- Virginia Department of Conservation Easement
- Historic Resources
- Conservation Easement
- Virginia Outdoors
- Foundation Easement
- City of Virginia Beach
- Park
- Railroad
- DHR VCRIS
- Archaeological Resource
- Architectural Resource
- Approximate Underground Gas Line
- Approximate Underground Sewer Line
- Approximate Water Line
- Hospital
- School
- Place of Worship
- Covalescent Center
- Point of Interest
- Cemetery

- Notes:**
1. Basemap from ESRI Topographic and World Street Map
  2. Project right-of-way, water sewer and gas lines from Dominions ET GIS
  3. Railroad from VGIN and easements from VDOR and USGS PDUS
  4. Historic resources from VDH
  5. Historic resources from VDH
  6. Historic resources from VDH
  7. Places digitized from Google Earth

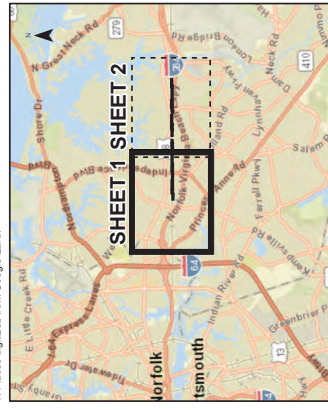

SHEET 1 OF 2

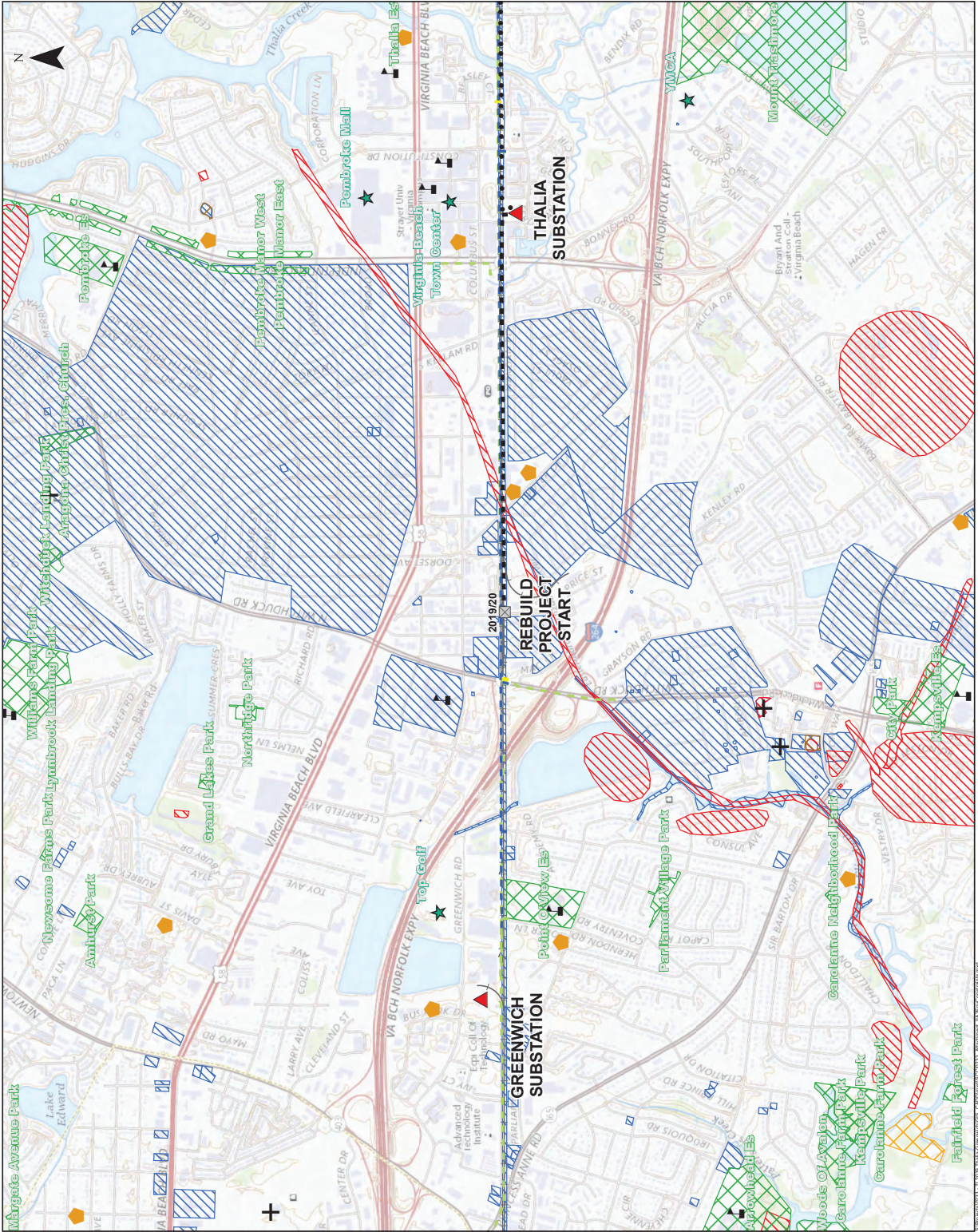

ATTACHMENT II.A.2

**ENVIRONMENTAL CONSTRAINTS MAP**

Lines #2019 and #2007 Rebuild Project

City of Virginia Beach, Virginia

Owner/Applicant:

Dominion Energy Virginia

C2 Env Project: 0233

Prepared By: GCF

Date: 07/19/22

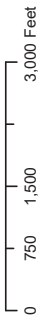

**LEGEND**

- Existing Line #2019
- Existing Line #2007
- Project Centerline
- Project Centerline 2019/20
- Existing Substation
- Virginia Department of Historic Resources
- Conservation Easement
- Virginia Outdoors Foundation Easement
- City of Virginia Beach Park
- Railroad
- DHR VCRIS Resource
- Archaeological Resource
- DHR VCRIS Architectural Resource
- Approximate Underground Gas Line
- Approximate Underground Sewer Line
- Approximate Water Line
- Hospital
- School
- Place of Worship
- Covalescent Center
- Point of Interest
- Cemetery

- Notes:**
1. Base map from ESRI Topographic and World Street Map
  2. Project right-of-way, water sewer and gas lines from Dominions ET GIS
  3. Railroad from VGIN track and easements from VDOR and USGS PADUS
  4. Historic resources from VDHHR
  5. Places digitized from Google Earth

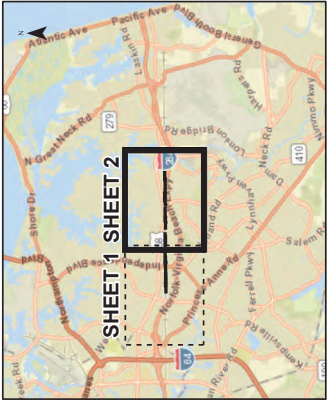

SHEET 2 OF 2

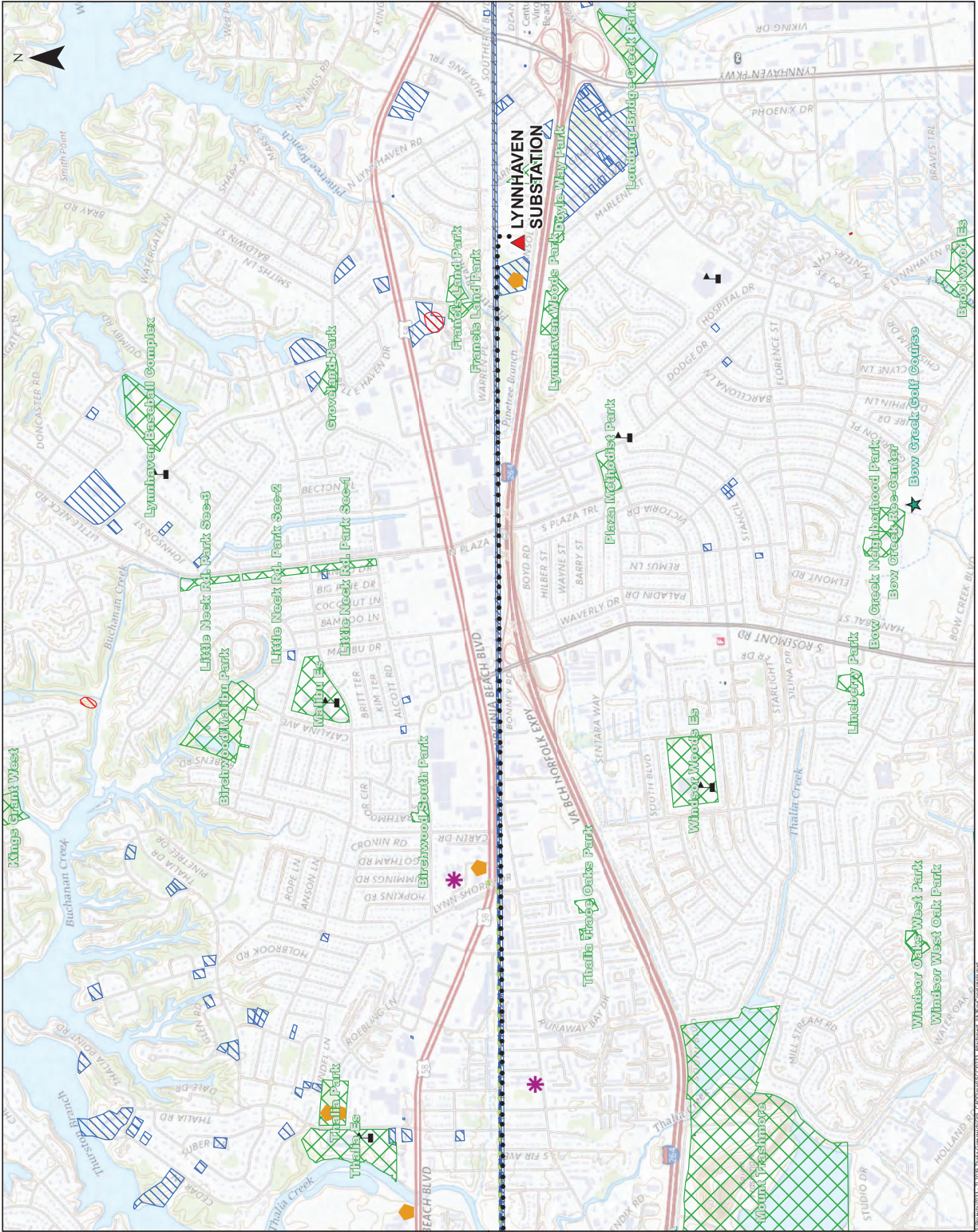

## II. DESCRIPTION OF THE PROPOSED PROJECT

### A. Right-of-way (“ROW”)

3. Provide a separate color map of a suitable scale showing all the Applicant’s transmission line ROWs, either existing or proposed, in the vicinity of the proposed project.

Response: See Attachment I.G.1.

**II. DESCRIPTION OF THE PROPOSED PROJECT**

**A. Right-of-way (“ROW”)**

- 4. To the extent the proposed route is not entirely within existing ROW, explain why existing ROW cannot adequately service the needs of the Applicant.**

Response: Not applicable.

## II. DESCRIPTION OF THE PROPOSED PROJECT

### A. Right-of-way (“ROW”)

5. Provide drawings of the ROW cross section showing typical transmission line structure placements referenced to the edge of the ROW. These drawings should include:
  - a. ROW width for each cross section drawing;
  - b. Lateral distance between the conductors and edge of ROW;
  - c. Existing utility facilities on the ROW; and
  - d. For lines being rebuilt in existing ROW, provide all of the above (i) as it currently exists, and (ii) as it will exist at the conclusion of the proposed project.

Response: See Attachments II.A.5.a through II.A.5.l.

# SECTION 1: EXISTING

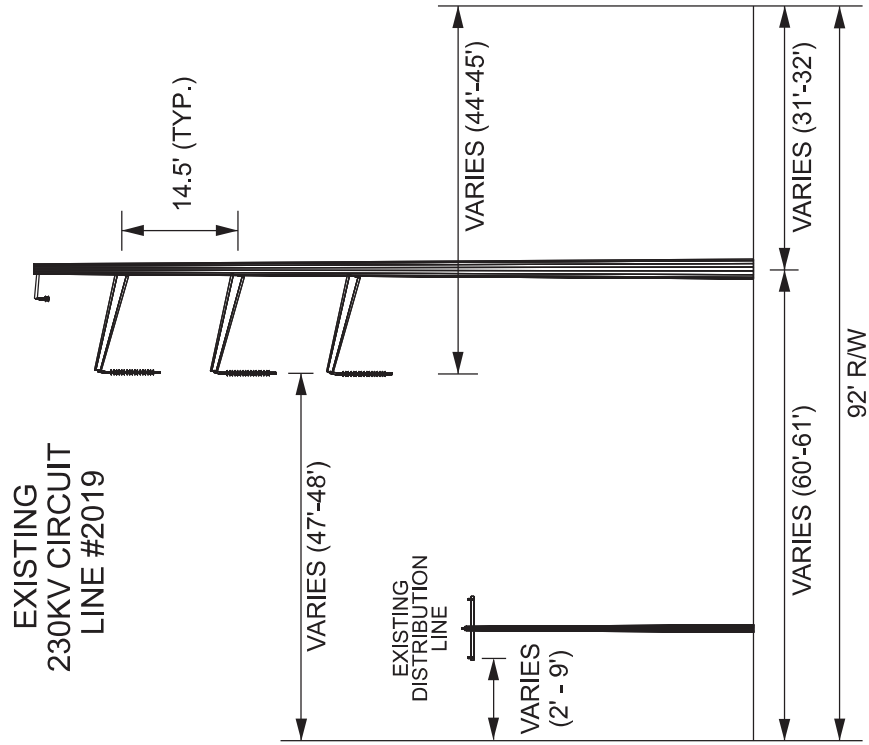

Dominion Energy  
 10900 Nuckols Road  
 Glen Allen, VA 23060

STR. 2019/21 - 2019/24

TYPICAL RIGHT OF WAY LOOKING TOWARDS  
 THALIA SUBSTATION

ORIG.		REV.		DRAWING NO.
DRAWN	TMR			ATTACHMENT II.A.5.a
CHECKED				
APPROVED				
DATE				

# SECTION 1: PROPOSED

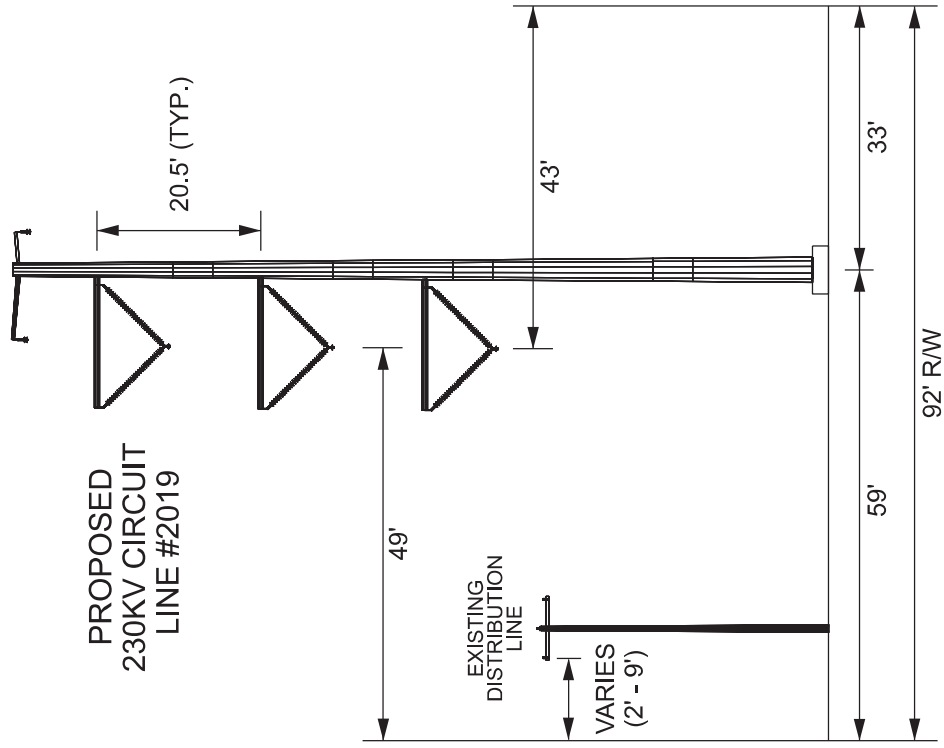

NOTE: INFORMATION CONTAINED ON DRAWING IS CONSIDERED PRELIMINARY IN NATURE AND SUBJECT TO CHANGE BASED ON FINAL DESIGN



Dominion Energy  
10900 Nuckols Road  
Glen Allen, VA 23060

STR. 2019/21 - 2019/24

TYPICAL RIGHT OF WAY LOOKING TOWARDS  
THALIA SUBSTATION

DRAWN	CHECKED	APPROVED	DATE	ORIG. TMR	REV.	DRAWING NO.
						ATTACHMENT II.A.5.b

# SECTION 2: EXISTING

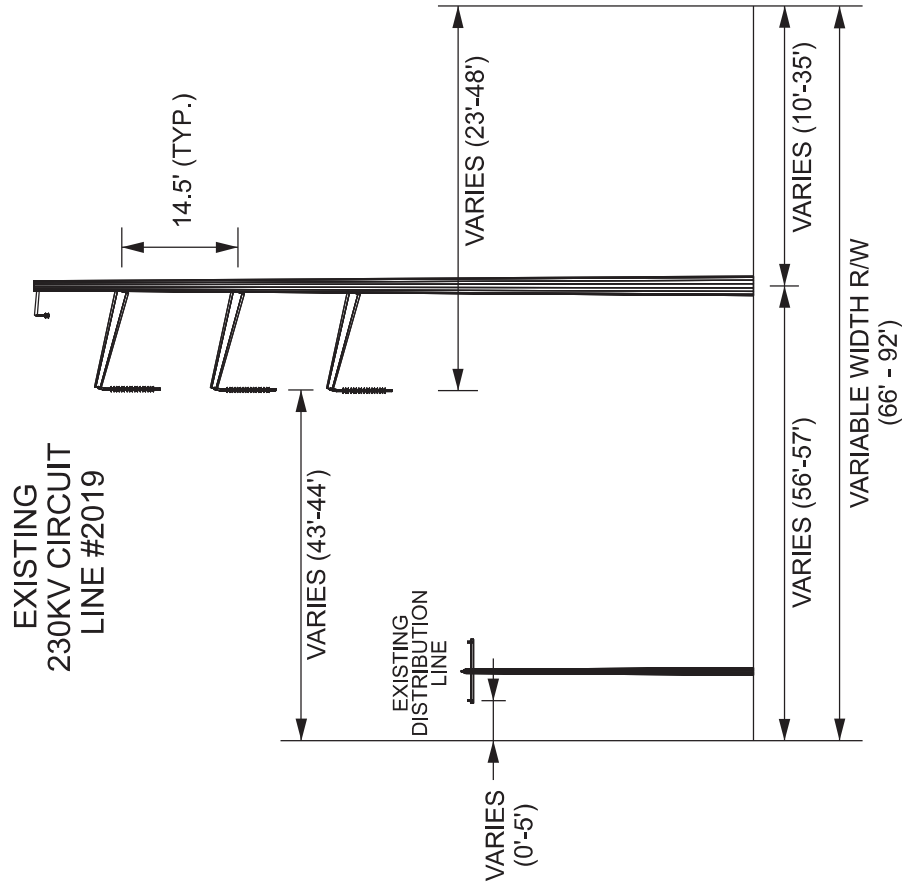

Dominion Energy  
10900 Nuckols Road  
Glen Allen, VA 23060

STR. 2019/25 - 2019/26

TYPICAL RIGHT OF WAY LOOKING TOWARDS  
THALIA SUBSTATION

DRAWING NO.		REV.		DRAWING NO.	
DRAWN	TMR				
CHECKED					ATTACHMENT II.A.5.c
APPROVED					
DATE					

# SECTION 2: PROPOSED

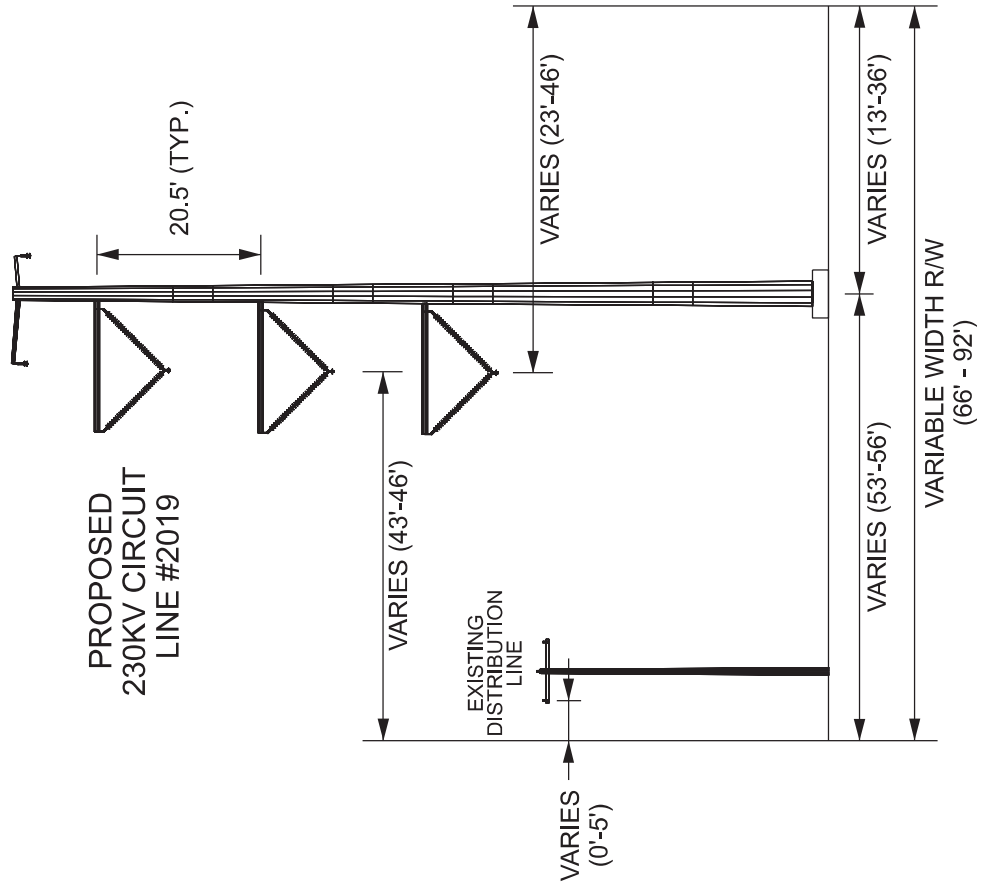

NOTE: INFORMATION CONTAINED ON DRAWING IS CONSIDERED PRELIMINARY IN NATURE AND SUBJECT TO CHANGE BASED ON FINAL DESIGN



Dominion Energy  
10900 Nuckols Road  
Glen Allen, VA 23060

STR. 2019/25 - 2019/26

TYPICAL RIGHT OF WAY LOOKING TOWARDS  
THALIA SUBSTATION

DRAWN		ORIG.	REV.	REV.	DRAWING NO.
CHECKED		TMR			ATTACHMENT II.A.5.d
APPROVED					
DATE					

# SECTION 3: EXISTING

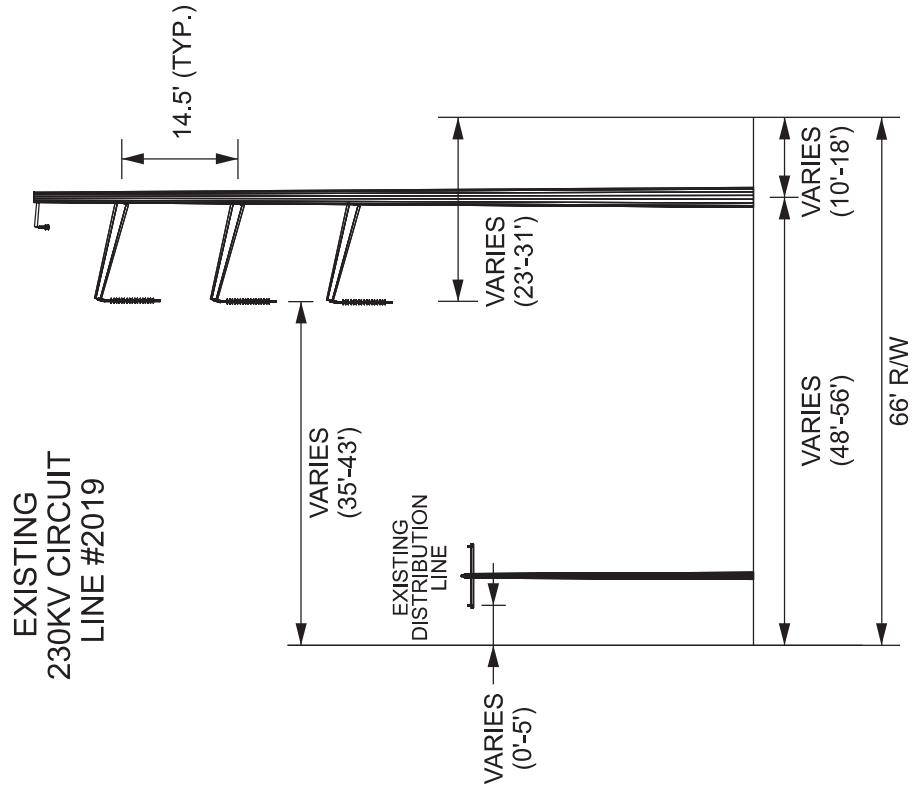

Dominion Energy  
 10900 Nuckols Road  
 Glen Allen, VA 23060

STR. 2019/27 - 2019/41

TYPICAL RIGHT OF WAY LOOKING TOWARDS  
 THALIA SUBSTATION

DRAWN		ORIG.	REV.	REV.	DRAWING NO.
CHECKED	TMR				ATTACHMENT II.A.5.e
APPROVED					
DATE					

### SECTION 3: PROPOSED

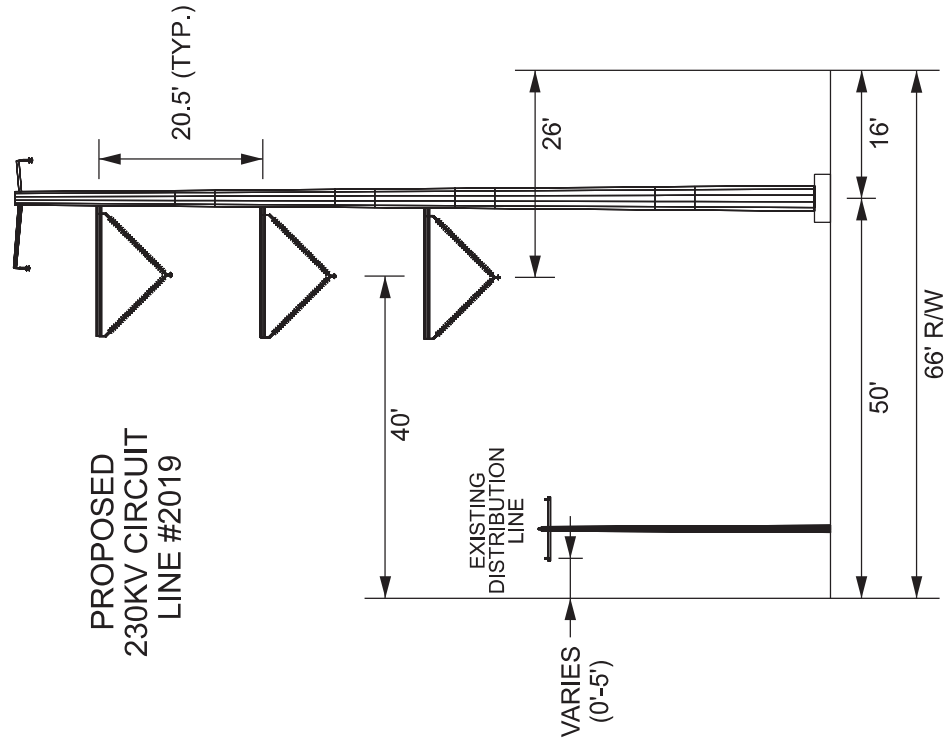

PROPOSED  
230KV CIRCUIT  
LINE #2019

NOTE: INFORMATION CONTAINED ON DRAWING IS CONSIDERED PRELIMINARY IN NATURE AND SUBJECT TO CHANGE BASED ON FINAL DESIGN



Dominion Energy  
10900 Nuckols Road  
Glen Allen, VA 23060

STR. 2019/27 - 2019/41  
TYPICAL RIGHT OF WAY LOOKING TOWARDS  
THALIA SUBSTATION

ORIG.		REV.		DRAWING NO.	
DRAWN	TMR				
CHECKED					ATTACHMENT II.A.5.f
APPROVED					
DATE					

# SECTION 4: EXISTING

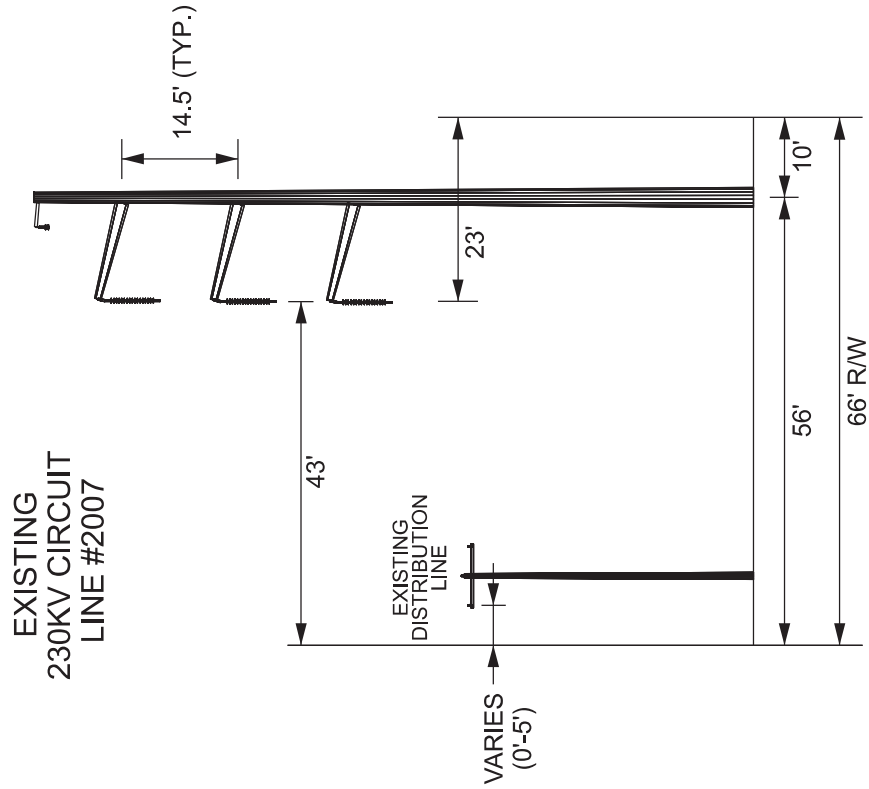

Dominion Energy  
 10900 Nuckols Road  
 Glen Allen, VA 23060

STR. 2007/42A - 2007/47  
 TYPICAL RIGHT OF WAY LOOKING TOWARDS  
 LYNNHAVEN SUBSTATION

ORIG.		REV.		DRAWING NO.
DRAWN	TMR			ATTACHMENT II.A.5.g
CHECKED				
APPROVED				
DATE				

# SECTION 4: PROPOSED

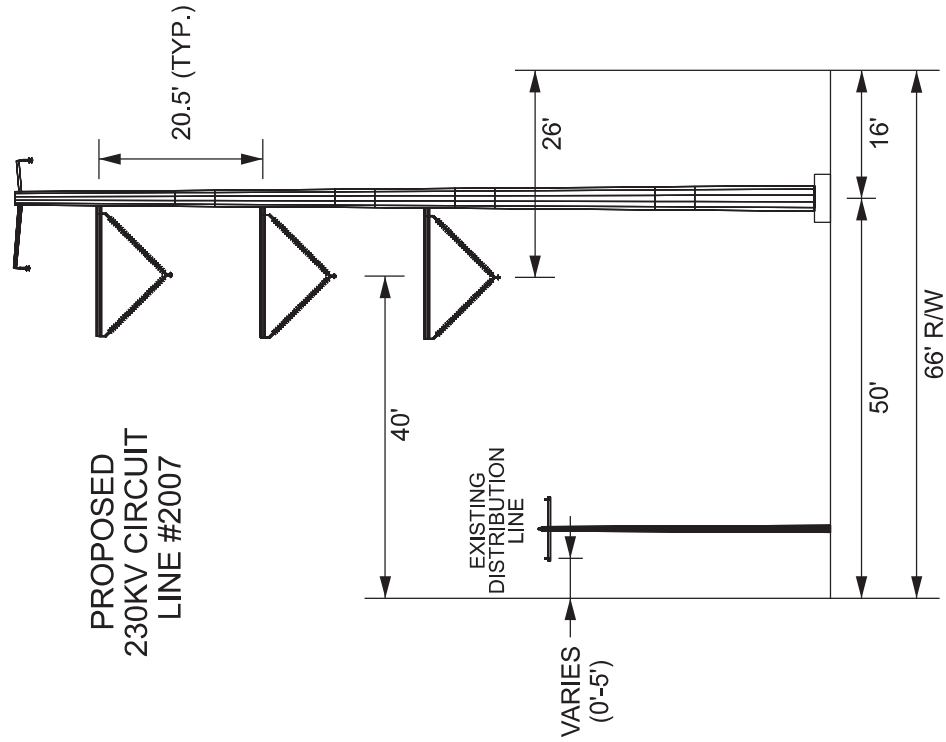

PROPOSED  
230KV CIRCUIT  
LINE #2007

NOTE: INFORMATION CONTAINED ON DRAWING IS CONSIDERED PRELIMINARY IN NATURE AND SUBJECT TO CHANGE BASED ON FINAL DESIGN



Dominion Energy  
10900 Nuckols Road  
Glen Allen, VA 23060

STR. 2007/42A - 2007/47  
TYPICAL RIGHT OF WAY LOOKING TOWARDS  
LYNNHAVEN SUBSTATION

ORIG.		REV.		DRAWING NO.	
DRAWN	TMR				
CHECKED					ATTACHMENT II.A.5.h
APPROVED					
DATE					

# SECTION 5: EXISTING

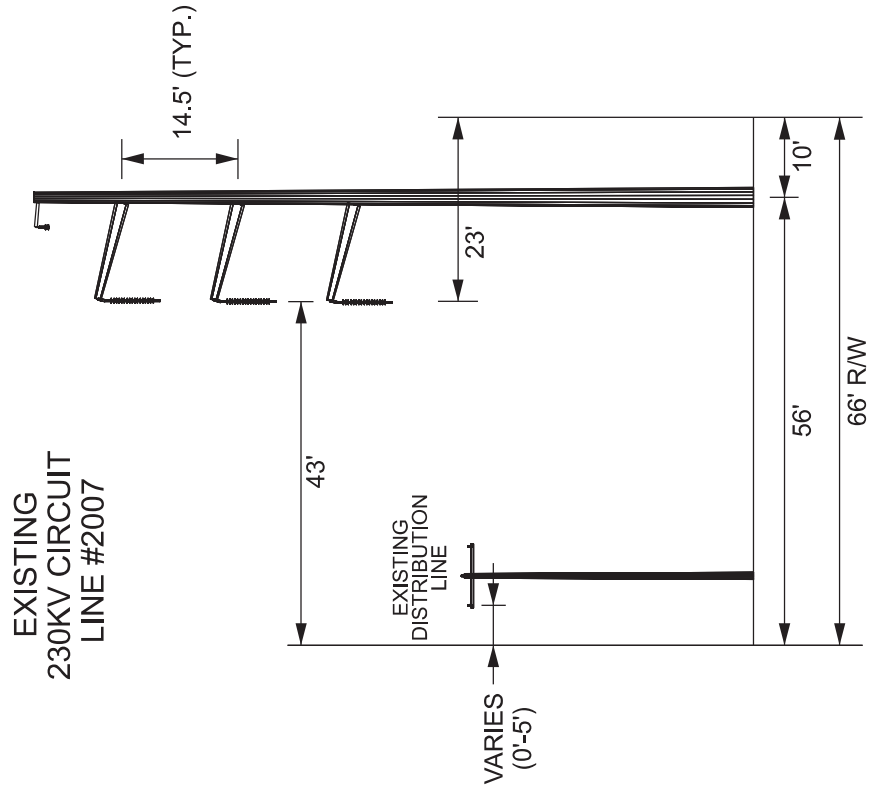

Dominion Energy  
 10900 Nuckols Road  
 Glen Allen, VA 23060

STR. 2007/48 - 2007/51  
 TYPICAL RIGHT OF WAY LOOKING TOWARDS  
 LYNNHAVEN SUBSTATION

ORIG.		REV.		DRAWING NO.
DRAWN	TMR			ATTACHMENT II.A.5.i
CHECKED				
APPROVED				
DATE				

# SECTION 5: PROPOSED

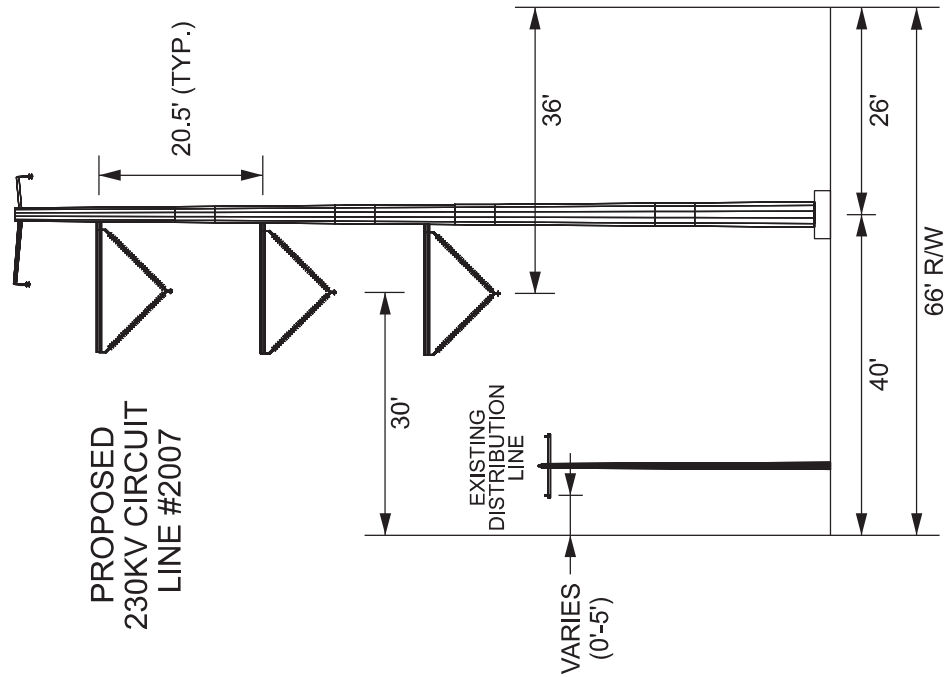

NOTE: INFORMATION CONTAINED ON DRAWING IS CONSIDERED PRELIMINARY IN NATURE AND SUBJECT TO CHANGE BASED ON FINAL DESIGN



Dominion Energy  
10900 Nuckols Road  
Glen Allen, VA 23060

STR. 2007/48 - 2007/51  
TYPICAL RIGHT OF WAY LOOKING TOWARDS  
LYNNHAVEN SUBSTATION

ORIG.		REV.		DRAWING NO.	
DRAWN	TMR				
CHECKED					ATTACHMENT II.A.5.j
APPROVED					
DATE					

# SECTION 6: EXISTING

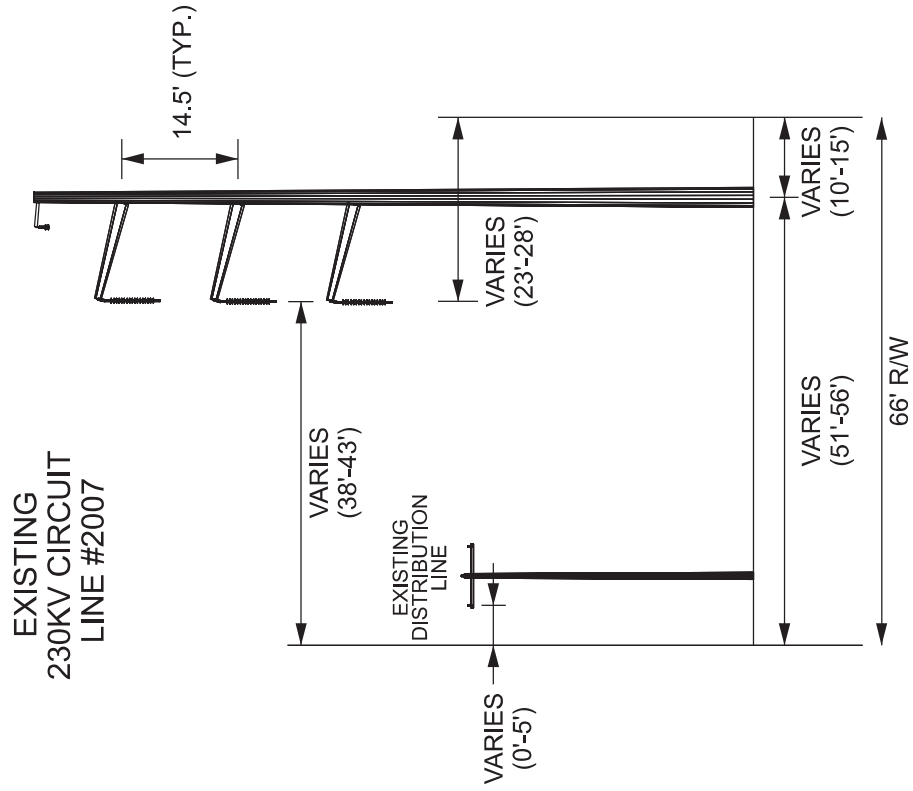

Dominion Energy  
 10900 Nuckols Road  
 Glen Allen, VA 23060

STR. 2007/52 - 2007/101  
 TYPICAL RIGHT OF WAY LOOKING TOWARDS  
 LYNNHAVEN SUBSTATION

ORIG.		REV.		DRAWING NO.
DRAWN	TMR			ATTACHMENT II.A.5.k
CHECKED				
APPROVED				
DATE				

# SECTION 6: PROPOSED

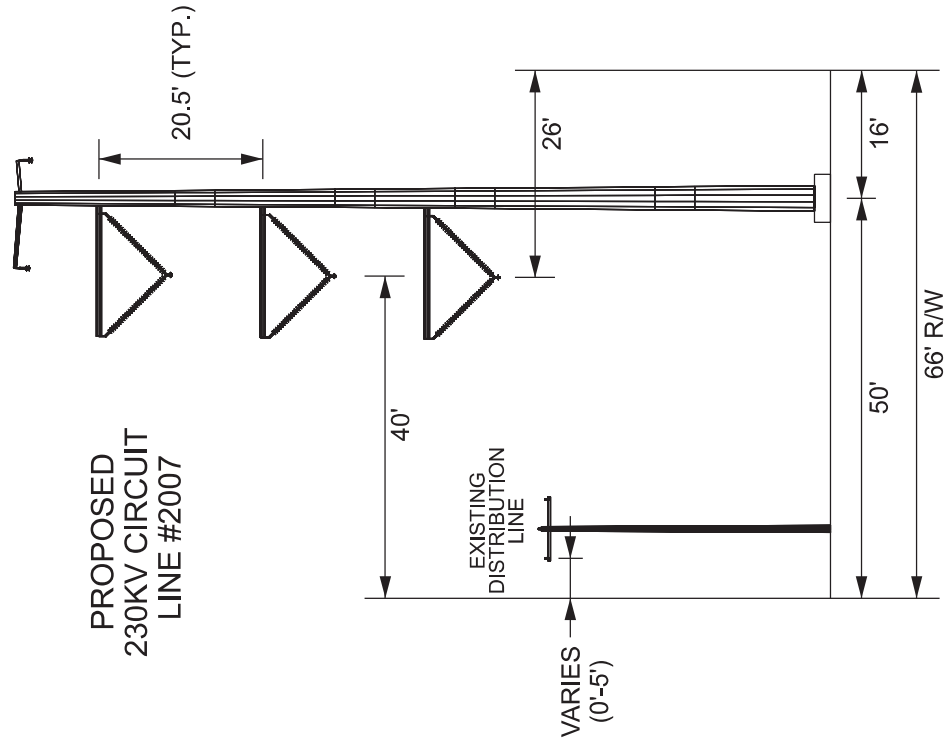

NOTE: INFORMATION CONTAINED ON DRAWING IS CONSIDERED PRELIMINARY IN NATURE AND SUBJECT TO CHANGE BASED ON FINAL DESIGN



Dominion Energy  
10900 Nuckols Road  
Glen Allen, VA 23060

STR. 2007/52 - 2007/101  
TYPICAL RIGHT OF WAY LOOKING TOWARDS  
LYNNHAVEN SUBSTATION

ORIG.		REV.		DRAWING NO.	
DRAWN	TMR			ATTACHMENT	
CHECKED				II.A.5.1	
APPROVED					
DATE					

## II. DESCRIPTION OF THE PROPOSED PROJECT

### A. Right-of-way (“ROW”)

#### 6. Detail what portions of the ROW are subject to existing easements and over what portions new easements will be needed.

Response: The Company acquired rights to use the existing approximately 4.54-mile right-of-way transmission corridor containing Lines #2019 and #2007 in 1930, which currently expire in 2029. The Company currently is negotiating with the City of Virginia Beach to extend those rights for use beyond 2029, as needed. The Company does not anticipate that any other new easements will be needed for the Rebuild Project. The Rebuild Project does not cross any conservation easements.

## II. DESCRIPTION OF THE PROPOSED PROJECT

### A. Right-of-way (“ROW”)

7. **Detail the proposed ROW clearing methods to be used and the ROW restoration and maintenance practices planned for the proposed project.**

Response: The existing right-of-way, which varies in width from 66 feet to 92 feet, as shown in Attachments II.A.5.a through II.A.5.l, is currently maintained for operation of the existing transmission facilities.

Trimming of tree limbs along the edge of the right-of-way may be conducted to support construction activities for the Rebuild Project. For any such minimal clearing, trees will be cut to no more than three inches above ground level. Trees located outside of the right-of-way that are tall enough to potentially impact the transmission facilities, commonly referred to as “danger trees,” may also need to be cut. Danger trees will be cut at or above ground level, limbed, and will remain where felled. No grubbing of roots or stumps will occur. Debris that is adjacent to homes will be disposed of by chipping or removal. In other areas, debris may be mulched or chipped as practicable. Danger tree removal will be accomplished by hand or from equipment placed on mats in wetland areas and within 100 feet of streams, if applicable. Care will be taken not to leave debris in streams or wetland areas that may cause an impediment to the flow of water. No mulching will occur in wetlands. Erosion control devices will be used on an ongoing basis, as appropriate, during all clearing and construction activities.

Erosion control will be maintained and temporary stabilization for all soil disturbing activities will be used until the right-of-way has been restored. Upon completion of the Rebuild Project, the Company will restore the right-of-way utilizing site rehabilitation procedures outlined in the Company’s *Standards & Specifications for Erosion & Sediment Control and Stormwater Management for Construction and Maintenance of Linear Electric Transmission Facilities* that was approved by the Virginia Department of Environmental Quality (“DEQ”). Time of year and weather conditions may affect when permanent stabilization takes place.

The right-of-way will continue to be maintained in its current state on a regular cycle to prevent interruptions to electric service and provide ready access to the right-of-way in order to patrol and make emergency repairs. Periodic maintenance to control woody growth will consist of hand cutting, machine mowing and herbicide application.

## II. DESCRIPTION OF THE PROPOSED PROJECT

### A. Right-of-way (“ROW”)

#### 8. Indicate the permitted uses of the proposed ROW by the easement landowner and the Applicant.

Response: Any non-transmission use will be permitted that:

- Is in accordance with the terms of the easement agreement for the right-of-way;
- Is consistent with the safe maintenance and operation of the transmission lines;
- Will not restrict future line design flexibility; and,
- Will not permanently interfere with future construction.

Subject to the terms of the easement, examples of typical permitted uses include but are not limited to:

- Agriculture;
- Hiking Trails;
- Fences;
- Perpendicular Road Crossings;
- Perpendicular Utility Crossings;
- Residential Driveways; and,
- Wildlife / Pollinator Habitat.

## II. DESCRIPTION OF THE PROPOSED PROJECT

### A. Right-of-way (“ROW”)

9. **Describe the Applicant’s route selection procedures. Detail the feasible alternative routes considered. For each such route, provide the estimated cost and identify and describe the cost classification (e.g. “conceptual cost,” “detailed cost,” etc.). Describe the Applicant’s efforts in considering these feasible alternatives. Detail why the proposed route was selected and other feasible alternatives were rejected. In the event that the proposed route crosses, or one of the feasible routes was rejected in part due to the need to cross, land managed by federal, state, or local agencies or conservation easements or open space easements qualifying under §§ 10.1-1009 – 1016 or §§ 10.1-1700 – 1705 of the Code (or a comparable prior or subsequent provision of the Code), describe the Applicant’s efforts to secure the necessary ROW.**

Response: The Company’s route selection for transmission line rebuild projects begins with a review of the existing rights-of-way. This approach generally minimizes impacts on the natural and human environments. This approach is also consistent with Attachment 1 of these Guidelines, which provides a tool routinely used by the Company in routing its transmission line projects. Specifically, this approach is consistent with Guideline #1, which states that existing rights-of-way should be given priority when adding new transmission facilities, and Va. Code §§ 56-46.1 and 56-259, which promote the use of existing rights-of-way for new transmission facilities. For the proposed Rebuild Project, the existing transmission corridor right-of-way that currently contains Line #2019 and Line #2007 is adequate.

Because the existing right-of-way and Company-owned property is adequate to construct the proposed Rebuild Project, no new right-of-way is necessary. Given the availability of existing right-of-way and the statutory preference given to the use of existing rights-of-way, and because additional costs and environmental impacts would be associated with the acquisition of and construction on new right-of-way, the Company did not consider any alternate routes requiring new right-of-way for the Rebuild Project.

## II. DESCRIPTION OF THE PROPOSED PROJECT

### A. Right-of-way (“ROW”)

10. **Describe the Applicant’s construction plans for the project, including how the Applicant will minimize service disruption to the affected load area. Include requested and approved line outage schedules for affected lines as appropriate.**

Response: Service to customers will not be interrupted during construction of the Rebuild Project. The Company plans to take Lines #2019 and 2007 out of service in two separate, sequential outages during the construction portion of the Rebuild Project. Assuming the final order is received by September 1, 2023, as requested in Section I.H, the current plan is to start construction in July 2024, and to complete construction by December 31, 2025. The first outage is expected to be taken between the Greenwich Substation and the Thalia Substation on Line #2019. During this time, the Thalia Substation will be fed from the Lynnhaven Substation. The second outage is expected to be taken between the Thalia Substation and the Lynnhaven Substation on Line #2007. During this time, the Thalia Substation will be fed from the Greenwich Substation.

The Company will request line outages from PJM prior to the date of such outages. It is customary for PJM to not grant approval of the outages until shortly before the outages are expected to occur and, therefore, they may be subject to change.

In addition to the work-related outages discussed above, the Company will take brief safety-related outages on Lines #2072 and #2025 at Lynnhaven Substation during construction of the Rebuild Project, as Line #2007 shares a structure and the backbone with these lines. The Company is not planning to conduct any work on either Line #2072 or #2025 as part of the Rebuild Project, and does not anticipate any disruption to customers due to these brief safety-related outages. The Company will request the outages on Lines #2072 and #2025 from PJM at the appropriate time.

## II. DESCRIPTION OF THE PROPOSED PROJECT

### A. Right-of-way (“ROW”)

#### 11. Indicate how the construction of this transmission line follows the provisions discussed in Attachment 1 of these Guidelines.

Response: As noted in Section II.A.9, Attachment 1 of these Guidelines provides a tool routinely used by the Company in routing its transmission line projects.

The Company utilized Guideline #1 (existing rights-of-way should be given priority when adding additional facilities) by siting the proposed Rebuild Project within the existing transmission corridor.

By utilizing the existing transmission corridor, the proposed Rebuild Project will minimize impact to any site listed on the National Register of Historic Places (“NRHP”). Thus, the proposed Rebuild Project is consistent with Guideline #2 (where practical, rights-of-way should avoid sites listed on the NRHP). In any event, the Company will coordinate with the Virginia Department of Historic Resources (“VDHR”) regarding its plans prior to engineering and construction of the Rebuild Project to avoid or minimize impacts. A Stage I Pre-Application Analysis prepared by Dutton & Associates (“Dutton”) was submitted to the VDHR on July 13, 2022, as further discussed in Section III.A of this Appendix. See Attachment 2.I.2 of the DEQ Supplement. The Company will coordinate with VDHR through review of the Stage I Pre-Application Analysis regarding these findings.

The Company has communicated with local, state, and federal agencies prior to filing this Application, consistent with Guideline #4 (where government land is involved the applicant should contact the agencies early in the planning process). See Sections III.B and III.J of this Appendix and the DEQ Supplement.

The Company follows construction methods in the Guidelines on a site-specific basis for typical construction projects (Guideline #8, #10, #11, #15, #16, #18, and #22).

The Company also utilizes the Guidelines in clearing right-of-way, constructing facilities, and maintaining rights-of-way after construction. Moreover, secondary uses of right-of-way that are consistent with the safe maintenance and operation of facilities are permitted, as noted in Section II.A.8.

## II. DESCRIPTION OF THE PROPOSED PROJECT

### A. Right-of-way (“ROW”)

12. a. **Detail counties and localities through which the line will pass. If any portion of the line will be located outside of the Applicant’s certificated service area: (1) identify each electric utility affected; (2) state whether any affected electric utility objects to such construction; and (3) identify the length of line(s) proposed to be located in the service area of an electric utility other than the Applicant; and**
- b. **Provide three (3) color copies of the Virginia Department of Transportation “General Highway Map” for each county and city through which the line will pass. On the maps show the proposed line and all previously approved and certificated facilities of the Applicant. Also, where the line will be located outside of the Applicant’s certificated service area, show the boundaries between the Applicant and each affected electric utility. On each map where the proposed line would be outside of the Applicant’s certificated service area, the map must include a signature of an appropriate representative of the affected electric utility indicating that the affected utility is not opposed to the proposed construction within its service area.**

Response:

- a. The proposed Rebuild Project traverses the City of Virginia Beach for a total of approximately 4.54 miles. The Rebuild Project is located entirely within Dominion Energy Virginia’s service territory.
- b. An electronic copy of the Virginia Department of Transportation (“VDOT”) “General Highway Map” for the Southeastern Virginia Metropolitan Area, which includes the City of Virginia Beach, is marked as required and submitted with the Application. A reduced copy of the map is provided as Attachment II.A.12.b.

# Southeastern Metropolitan Area Road Map

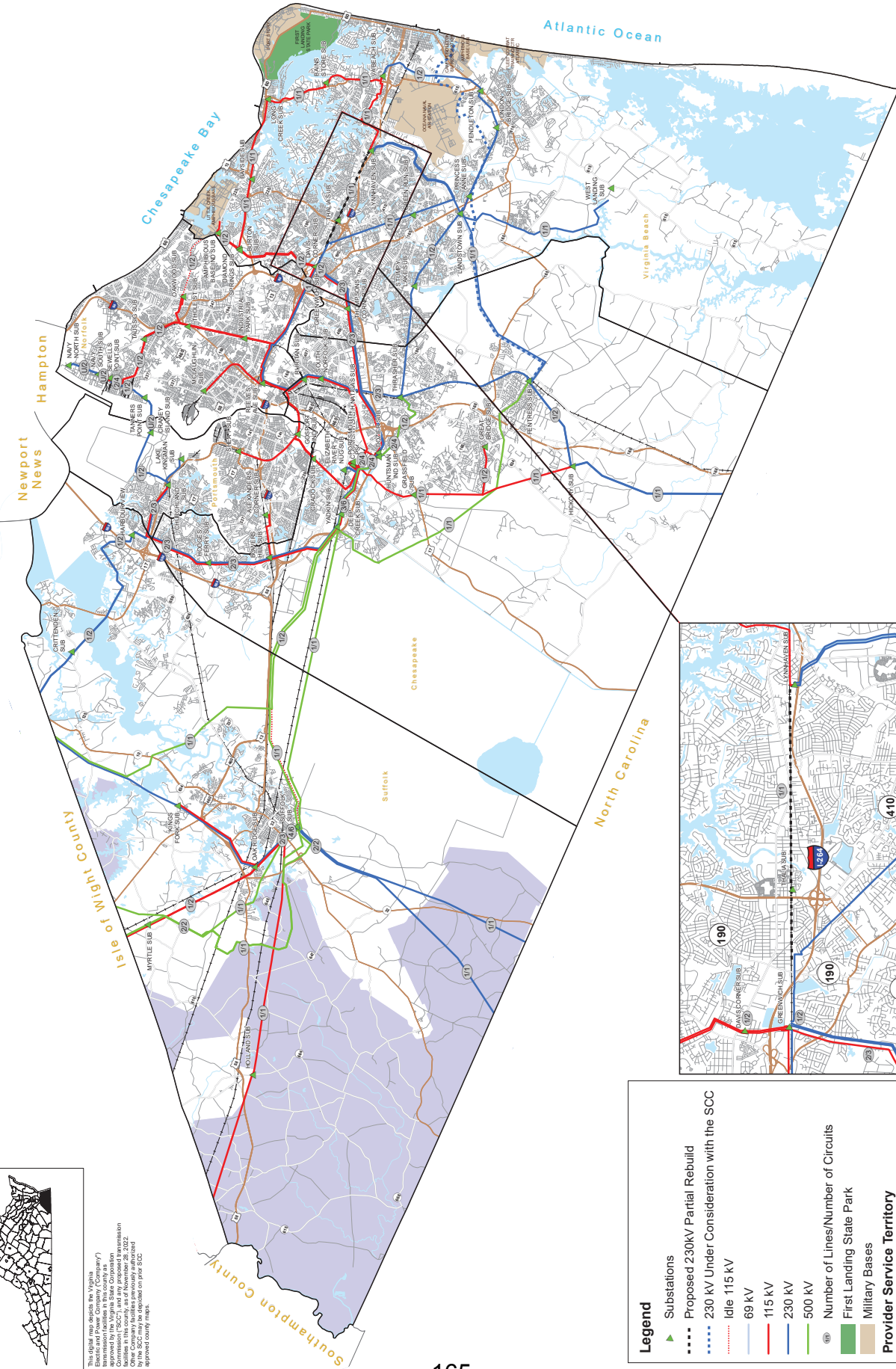

**Southeastern Metropolitan Area**  
 Cities of: Chesapeake, Portsmouth  
 Norfolk, Virginia Beach, and Suffolk

VEPCO and other road data  
 County data, current as of  
 July 2011.

0 1 2 4 6 8  
 Miles

**Legend**

- ▲ Substations
- Proposed 230kV Partial Rebuild
- 230 kV Under Consideration with the SCC
- Idle 115 kV
- 69 kV
- 115 kV
- 230 kV
- 500 kV
- Ⓢ Number of Lines/Number of Circuits
- First Landing State Park
- Military Bases
- Provider Service Territory
- VEPCO
- CEC

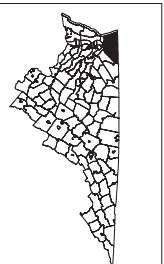

This digital map depicts the Virginia Electric and Power Company (Company) facilities and power lines as approved by the Virginia State Corporation Commission in this county, as of November 28, 2012. Other facilities previously authorized by the Commission are shown on this approved county map.

## II. DESCRIPTION OF THE PROPOSED PROJECT

### B. Line Design and Operational Features

1. **Detail the number of circuits and their design voltage, initial operational voltage, any anticipated voltage upgrade, and transfer capabilities.**

Response: The 1.17-mile segment of 230 kV Line #2019 proposed for rebuild will be designed and operated at 230 kV with no anticipated voltage upgrades and will have a summer transfer capability 1,573 MVA.

The 3.37-mile Line #2007 proposed for rebuild will be designed and operated at 230 kV with no anticipated voltage upgrades and will have a summer transfer capability 1,573 MVA.

## II. DESCRIPTION OF THE PROPOSED PROJECT

### B. Line Design and Operational Features

2. **Detail the number, size(s), type(s), coating and typical configurations of conductors. Provide the rationale for the type(s) of conductor(s) to be used.**

Response: The proposed conductor for 230 kV Lines #2019 and #2007 will be three-phase twin-bundled 768.2 ACSS/TW/HS conductors arranged in a phase-over-phase orientation with two fiber optic shield wires. See Attachments II.B.3.a through II.B.3.c for more details on conductor configurations at each structure type.

The twin-bundled 768.2 ACSS/TW/HS conductors are the Company's standard for new 230 kV construction.

## **II. DESCRIPTION OF THE PROPOSED PROJECT**

### **B. Line Design and Operational Features**

- 3. With regard to the proposed supporting structures over each portion of the ROW for the preferred route, provide diagrams (including foundation reveal) and descriptions of all the structure types, to include:**
  - a. mapping that identifies each portion of the preferred route;**
  - b. the rationale for the selection of the structure type;**
  - c. the number of each type of structure and the length of each portion of the ROW;**
  - d. the structure material and rationale for the selection of such material;**
  - e. the foundation material;**
  - f. the average width at cross arms;**
  - g. the average width at the base;**
  - h. the maximum, minimum and average structure heights;**
  - i. the average span length; and**
  - j. the minimum conductor-to-ground clearances under maximum operating conditions.**

Response: See Attachments II.B.3.a through II.B.3.c.

\$SYTIME\$

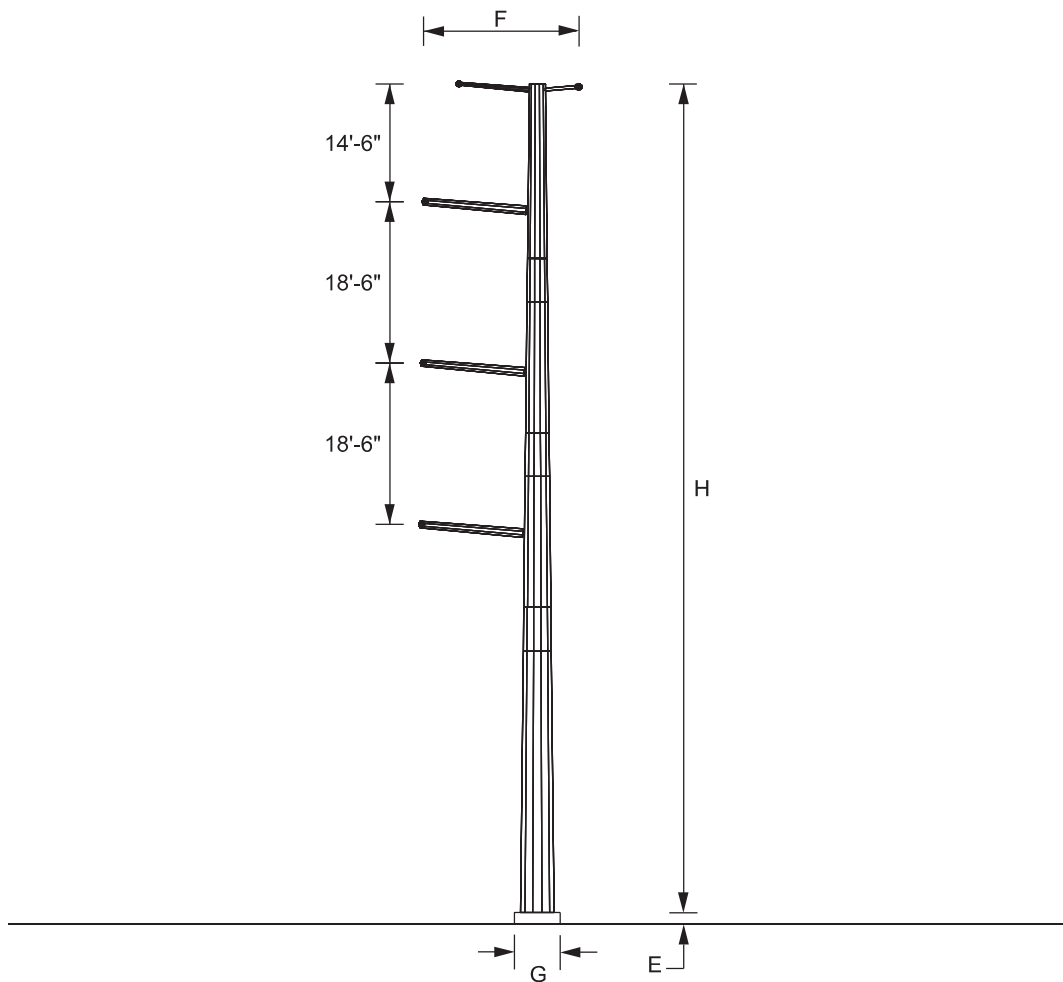

**TYPICAL SINGLE CIRCUIT MONOPOLE DDE STRUCTURE (WITH COND. ARMS)**

A. STRUCTURE MAPPING	SEE ATTACHMENT II.B.5.a
B. RATIONALE FOR STRUCTURE TYPE:	MATCHES THE EXISTING STRUCTURES VERTICAL CONFIGURATION
C. LENGTH OF R/W (STRUCTURE QTY):	4.54 MILES (11)
D. STRUCTURE MATERIAL:	GALVANIZED STEEL
RATIONALE FOR STRUCTURE MATERIAL:	GALVANIZED STEEL WAS SELECTED TO BEST MATCH THE AESTHETIC OF THE EXISTING CONCRETE POLES IN THE CORRIDOR
E. FOUNDATION MATERIAL:	CONCRETE
AVERAGE FOUNDATION REVEAL:	SEE NOTE 4
F. AVERAGE WIDTH AT CROSSARM:	18'
G. AVERAGE WIDTH AT BASE:	6' DIAMETER FOUNDATION (SEE NOTE 1)
H. MINIMUM STRUCTURE HEIGHT:	92'
MAXIMUM STRUCTURE HEIGHT:	97'
AVERAGE STRUCTURE HEIGHT:	94'
I. AVERAGE SPAN LENGTH (RANGE):	282' (123' - 365')
J. MINIMUM CONDUCTOR-TO-GROUND:	22.5' (AT MAXIMUM OPERATING TEMPERATURE)

NOTES  
 1. INFORMATION ON DRAWING IS PRELIMINARY AND SUBJECT TO CHANGE DURING FINAL ENGINEERING  
 2. INDIVIDUAL POLE HEIGHTS ABOVE GROUND MAY VARY SUBJECT TO FINAL LOCATION AND TERRAIN  
 3. STRUCTURE HEIGHTS ARE MEASURED FROM STRUCTURE CENTERLINE  
 4. MINIMUM FOUNDATION REVEAL SHALL BE 1.5', MAX REVEAL SUBJECT TO FINAL LOCATION AND TERRAIN

\$DGN\$SPEC\$

TESBORDI

**Electric Transmission**



Dominion Energy  
 10900 Nuckols Road  
 Glen Allen, VA 23060

LINES 2007 & 2019

TYPICAL DOUBLE DEAD-END  
 STRUCTURE (WITH COND. ARMS)

DRAWING NO.

ATTACHMENT II.B.3.a

DRAWN TMR

\$SYTIME\$

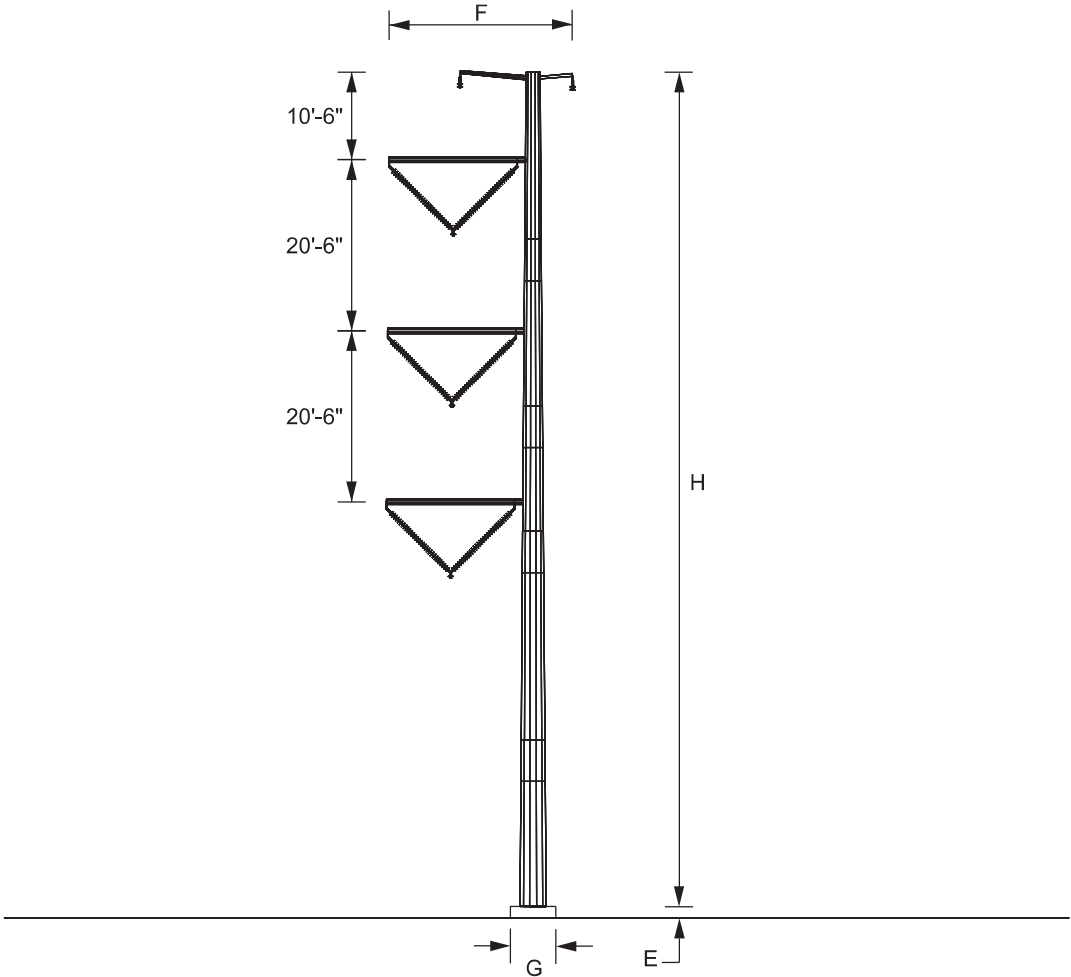

**TYPICAL SINGLE CIRCUIT MONOPOLE SUSPENSION STRUCTURE**

A. STRUCTURE MAPPING	SEE ATTACHMENT II.B.5.a
B. RATIONALE FOR STRUCTURE TYPE:	MATCHES THE EXISTING STRUCTURES VERTICAL CONFIGURATION, V-STRING CHOSEN DUE TO NARROW RIGHT OF WAY
C. LENGTH OF R/W (STRUCTURE QTY):	4.54 MILES (69)
D. STRUCTURE MATERIAL:	GALVANIZED STEEL
RATIONALE FOR STRUCTURE MATERIAL:	GALVANIZED STEEL WAS SELECTED TO BEST MATCH THE AESTHETIC OF THE EXISTING CONCRETE POLES IN THE CORRIDOR
E. FOUNDATION MATERIAL:	CONCRETE
AVERAGE FOUNDATION REVEAL:	SEE NOTE 4
F. AVERAGE WIDTH AT CROSSARM:	22'
G. AVERAGE WIDTH AT BASE:	6' DIAMETER FOUNDATION (SEE NOTE 1)
H. MINIMUM STRUCTURE HEIGHT:	102'
MAXIMUM STRUCTURE HEIGHT:	117'
AVERAGE STRUCTURE HEIGHT:	105'
I. AVERAGE SPAN LENGTH (RANGE):	282' (123' - 365')
J. MINIMUM CONDUCTOR-TO-GROUND:	22.5' (AT MAXIMUM OPERATING TEMPERATURE)

NOTES  
 1. INFORMATION ON DRAWING IS PRELIMINARY AND SUBJECT TO CHANGE DURING FINAL ENGINEERING  
 2. INDIVIDUAL POLE HEIGHTS ABOVE GROUND MAY VARY SUBJECT TO FINAL LOCATION AND TERRAIN  
 3. STRUCTURE HEIGHTS ARE MEASURED FROM STRUCTURE CENTERLINE  
 4. MINIMUM FOUNDATION REVEAL SHALL BE 1.5', MAX REVEAL SUBJECT TO FINAL LOCATION AND TERRAIN

\$DGN\$SPEC\$

TESBORDI

 <b>Dominion Energy</b> Dominion Energy 10900 Nuckols Road Glen Allen, VA 23060	LINES 2007 & 2019  TYPICAL V-STRING SUSPENSION STRUCTURE	<b>DRAWING NO.</b>  ATTACHMENT II.B.3.b
	<b>DRAWN</b> TMR	

\$SYTIME\$

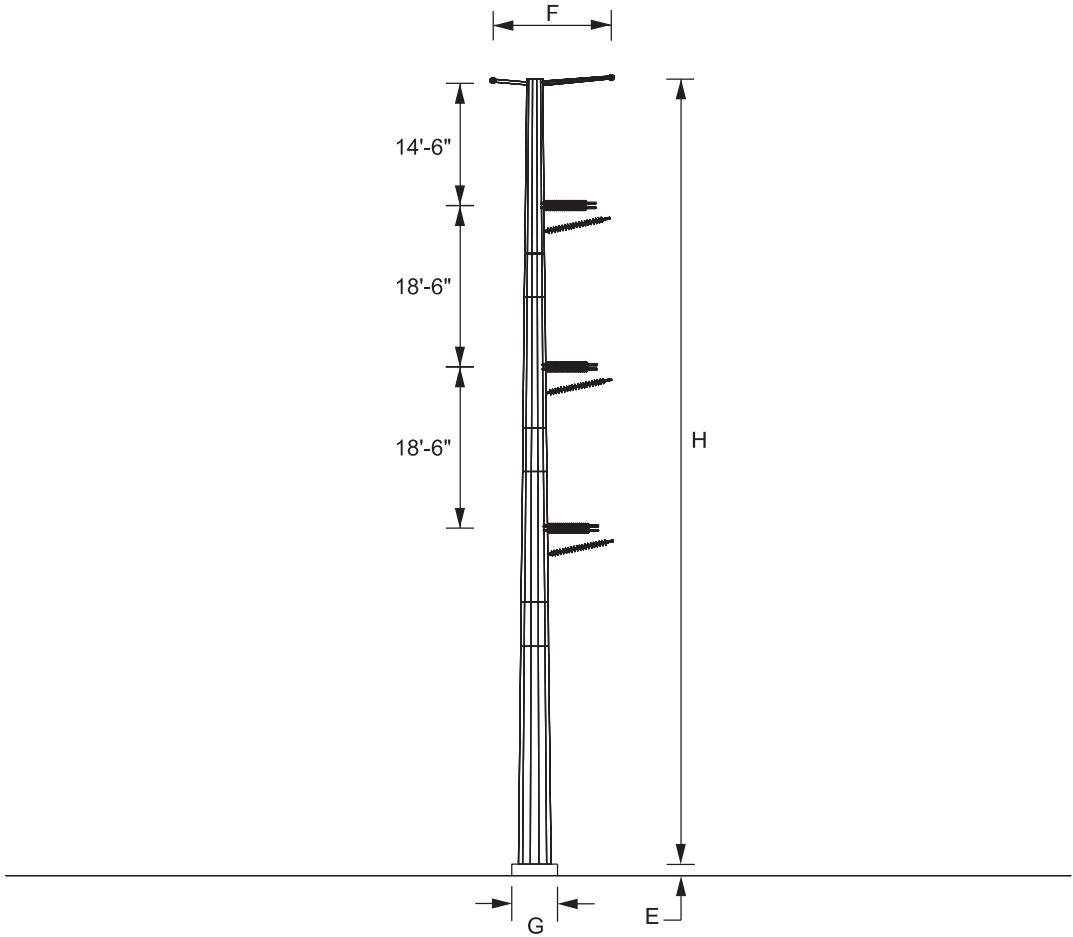

**TYPICAL SINGLE CIRCUIT MONOPOLE DDE STRUCTURE (NO COND. ARMS)**

A. STRUCTURE MAPPING	SEE ATTACHMENT II.B.5.a
B. RATIONALE FOR STRUCTURE TYPE:	MATCHES THE EXISTING STRUCTURES VERTICAL CONFIGURATION
C. LENGTH OF R/W (STRUCTURE QTY):	4.54 MILES (2)
D. STRUCTURE MATERIAL:	GALVANIZED STEEL
RATIONALE FOR STRUCTURE MATERIAL:	GALVANIZED STEEL WAS SELECTED TO BEST MATCH THE AESTHETIC OF THE EXISTING CONCRETE POLES IN THE CORRIDOR
E. FOUNDATION MATERIAL:	CONCRETE
AVERAGE FOUNDATION REVEAL:	SEE NOTE 4
F. AVERAGE WIDTH AT CROSSARM:	14'
G. AVERAGE WIDTH AT BASE:	6' DIAMETER FOUNDATION (SEE NOTE 1)
H. MINIMUM STRUCTURE HEIGHT:	92'
MAXIMUM STRUCTURE HEIGHT:	92'
AVERAGE STRUCTURE HEIGHT:	92'
I. AVERAGE SPAN LENGTH (RANGE):	282' (123' - 365')
J. MINIMUM CONDUCTOR-TO-GROUND:	22.5' (AT MAXIMUM OPERATING TEMPERATURE)

NOTES  
 1. INFORMATION ON DRAWING IS PRELIMINARY AND SUBJECT TO CHANGE DURING FINAL ENGINEERING  
 2. INDIVIDUAL POLE HEIGHTS ABOVE GROUND MAY VARY SUBJECT TO FINAL LOCATION AND TERRAIN  
 3. STRUCTURE HEIGHTS ARE MEASURED FROM STRUCTURE CENTERLINE  
 4. MINIMUM FOUNDATION REVEAL SHALL BE 1.5', MAX REVEAL SUBJECT TO FINAL LOCATION AND TERRAIN

\$DGN\$SPEC\$

TESBORDI

<p><b>Electric Transmission</b></p>  <p>Dominion Energy                  10900 Nuckols Road                  Glen Allen, VA 23060</p>	<p>LINES 2007 &amp; 2019</p> <p>TYPICAL DOUBLE DEAD-END                  STRUCTURE (NO COND. ARMS)</p>	<p>DRAWING NO.</p> <p>ATTACHMENT II.B.3.c</p>
		<p>DRAWN TMR</p>

## **II. DESCRIPTION OF THE PROPOSED PROJECT**

### **B. Line Design and Operational Features**

- 4. With regard to the proposed supporting structures for all feasible alternate routes, provide the maximum, minimum and average structure heights with respect to the whole route.**

Response: Not applicable.

## II. DESCRIPTION OF THE PROPOSED PROJECT

### B. Line Design and Operational Features

5. For lines being rebuilt, provide mapping showing existing and proposed structure heights for each individual structure within the ROW, as proposed in the application.

Response: See [Attachment II.B.5.a](#) for structure mapping.

See the table below for the existing and proposed heights of permanent structures related to the Rebuild Project. The proposed approximate structure heights are from the conceptual design created to estimate the cost of the Rebuild Project and are subject to change based on final engineering design. The approximate structure heights are above ground level (“AGL”) (i.e., they are inclusive of foundation reveal).

Structure Number	Existing Structure Height AGL (ft.)	Proposed Structure Height AGL (ft.)	Attachment II.B.3 Structure Type
2019/20, 245/38*	101	101	Existing
2019/21	83	92	II.B.3.a
2019/22	83	102	II.B.3.b
2019/23	88	102	II.B.3.b
2019/24	83	107	II.B.3.b
2019/25	95	117	II.B.3.b
2019/26	95	117	II.B.3.b
2019/27	85	107	II.B.3.b
2019/28	85	102	II.B.3.b
2019/29	87	102	II.B.3.b
2019/30	86	102	II.B.3.b
2019/31	86	102	II.B.3.b
2019/32	86	102	II.B.3.b
2019/33	86	102	II.B.3.b
2019/34	87	102	II.B.3.b
2019/35	84	102	II.B.3.b
2019/36	87	102	II.B.3.b
2019/37	87	92	II.B.3.a
2019/38	86	107	II.B.3.b
2019/39	87	107	II.B.3.b
2019/40	89	92	II.B.3.a

2019/41	83	92	II.B.3.c
2019/42*	35	35	Existing
2019/43	40	N/A	N/A
2019/42A	N/A	77	Static Pole
2019/42B	N/A	77	Static Pole
2007/41A	N/A	77	Static Pole
2007/41B	N/A	77	Static Pole
2007/41*	35	35	Existing
2007/42A	83	92	II.B.3.c
2007/42	84	92	II.B.3.a
2007/43	83	102	II.B.3.b
2007/44	89	107	II.B.3.b
2007/45	84	102	II.B.3.b
2007/46	84	102	II.B.3.b
2007/47	93	97	II.B.3.a
2007/48	95	97	II.B.3.a
2007/49	90	107	II.B.3.b
2007/50	94	107	II.B.3.b
2007/51	89	97	II.B.3.a
2007/52	86	97	II.B.3.a
2007/53	95	112	II.B.3.b
2007/54	96	117	II.B.3.b
2007/55	91	112	II.B.3.b
2007/56	89	107	II.B.3.b
2007/57	84	102	II.B.3.b
2007/58	84	107	II.B.3.b
2007/59	94	112	II.B.3.b
2007/60	84	107	II.B.3.b
2007/61	84	102	II.B.3.b
2007/62	95	107	II.B.3.b
2007/63	90	112	II.B.3.b
2007/64	90	112	II.B.3.b
2007/65	84	107	II.B.3.b
2007/67	84	102	II.B.3.b
2007/68	85	107	II.B.3.b
2007/69	91	107	II.B.3.b
2007/70	86	107	II.B.3.b

2007/71	96	112	II.B.3.b
2007/72	86	102	II.B.3.b
2007/73	89	102	II.B.3.b
2007/74	93	102	II.B.3.b
2007/75	94	102	II.B.3.b
2007/76	94	102	II.B.3.b
2007/77	84	102	II.B.3.b
2007/78	84	92	II.B.3.a
2007/79	94	107	II.B.3.b
2007/80	90	107	II.B.3.b
2007/81	84	92	II.B.3.a
2007/82	85	102	II.B.3.b
2007/83	94	102	II.B.3.b
2007/84	82	102	II.B.3.b
2007/85	93	102	II.B.3.b
2007/86	93	102	II.B.3.b
2007/87	95	107	II.B.3.b
2007/88	86	102	II.B.3.b
2007/89	86	102	II.B.3.b
2007/90	87	102	II.B.3.b
2007/91	89	102	II.B.3.b
2007/92	90	102	II.B.3.b
2007/93	84	102	II.B.3.b
2007/94	84	102	II.B.3.b
2007/95	84	102	II.B.3.b
2007/96	94	102	II.B.3.b
2007/97	90	102	II.B.3.b
2007/98	94	112	II.B.3.b
2007/99	94	112	II.B.3.b
2007/100	84	107	II.B.3.b
2007/101	90	97	II.B.3.a
2007/102	94	107	II.B.3.b
2007/103A	N/A	77	Static Pole
2007/103, 2072/1*	101	101	Existing
2007/104, 2025/90*	70	70	Existing
<b>Minimum**</b>	<b>82</b>	<b>92</b>	

<b>Maximum**</b>	<b>96</b>	<b>117</b>	
<b>Average**</b>	<b>88</b>	<b>103</b>	

\* Existing structure included as part of the Rebuild Project but not to be replaced.

\*\* Exclusive of static poles and structures not being replaced.

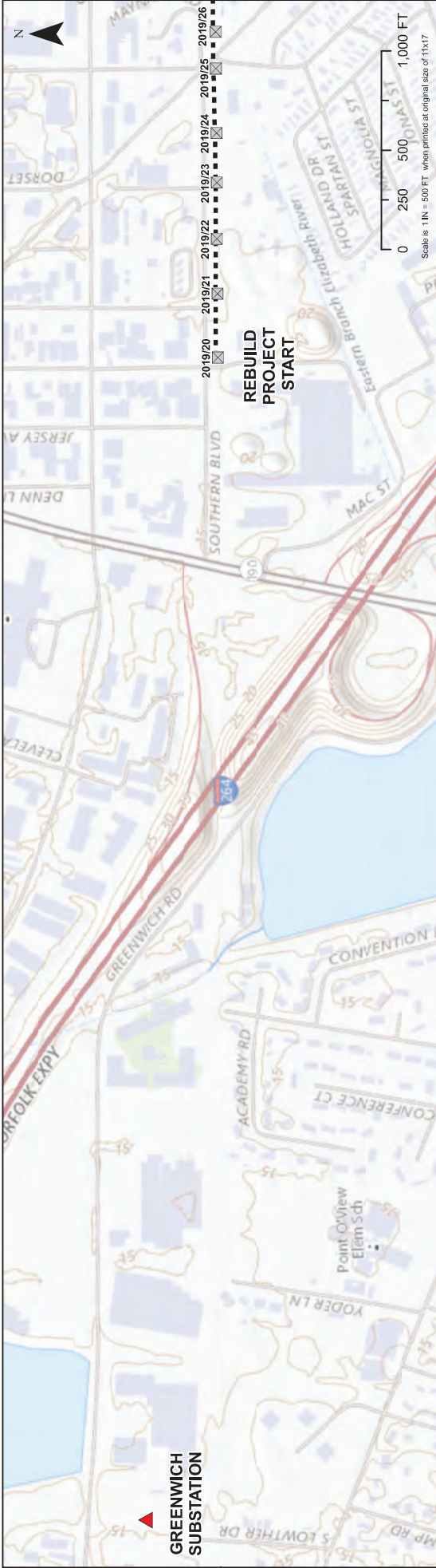
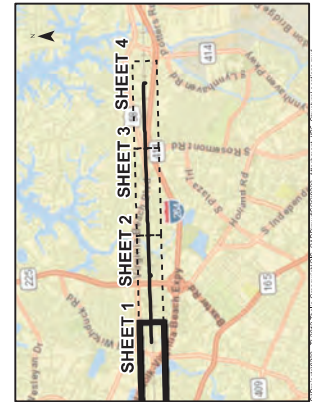

TABLE II.B.5

Structure Number	2019/20*	2019/21	2019/22	2019/23	2019/24	2019/25	2019/26
Existing Structure Height (Feet)	101	83	83	88	83	95	95
Proposed Structure Height (Feet)	101	92	102	102	107	117	117

\*Existing structure not to be replaced

- Notes: 1. Structure locations and heights provided by Dominion Energy Virginia.  
 2. Existing structures are to be replaced in the same approximate location with proposed locations subject to final engineering. The proposed approximate structure heights are from the conceptual design created to estimate the cost of the Rebuild Project and are subject to change based on final engineering design. The proposed structure heights are above ground level. In addition to replacing existing structures, some new structures are proposed within the Thalia and Lynnhaven Substations, as illustrated above.  
 3. Basemap from ESRI Topographic and World Street Map.



- SITE DATA**
- Existing Line #2019 Project Centerline
  - Existing Line #2007 Project Centerline
  - ⊠ Existing Structure
  - ⊠ New Structure
  - ▲ Existing Substation



**ATTACHMENT II.B.5  
 STRUCTURE LOCATION MAP**

Lines #2019 and #2007 Rebuild Project  
 City of Virginia Beach, Virginia  
 Owner/Applicant:  
 Dominion Energy Virginia  
 C2 Env Project: GCF  
 0233  
 Date: 07/19/22  
 SHEET 1 OF 4

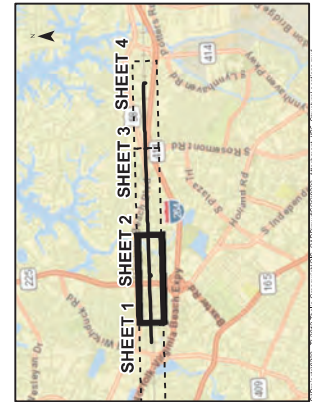

TABLE II.B.5

Structure Number	2019/27	2019/28	2019/29	2019/30	2019/31	2019/32	2019/33	2019/34	2019/35	2019/36	2019/37	2019/38	2019/39	2019/40	2019/41	2019/42*	2019/43	2019/42A	2019/42B
Existing Structure Height (Feet)	85	85	87	86	86	86	86	87	84	87	87	86	87	89	83	35	40	N/A	N/A
Proposed Structure Height (Feet)	107	102	102	102	102	102	102	102	102	102	92	107	107	92	92	35	N/A	77	77
Structure Number	2007/41A	2007/41B	2007/41*	2007/42A	2007/42	2007/43	2007/44	2007/45	2007/46	2007/47	2007/48	2007/49	2007/50	2007/51	2007/52	2007/53			
Existing Structure Height (Feet)	N/A	N/A	35	83	84	83	89	84	84	93	95	90	94	89	86	95			
Proposed Structure Height (Feet)	77	77	35	92	92	102	107	102	102	97	97	107	107	97	97	112			

\*Existing structure not to be replaced

- Notes:
- Structure locations and heights provided by Dominion Energy Virginia.
  - Existing structures are to be replaced in the same approximate location with proposed locations subject to final engineering. The proposed approximate structure heights are from the conceptual design created to estimate the cost of the Rebuild Project and are subject to change based on final engineering design. The proposed structure heights are above ground level. In addition to replacing existing structures, some new structures are proposed within the Thalia and Lynnhaven Substations, as illustrated above.
  - Basemap from ESRI Topographic and World Street Map.



SITE DATA

- Existing Line #2019 Project Centerline
- Existing Line #2007 Project Centerline
- ⊗ Existing Structure
- ⊠ New Structure
- ▲ Existing Substation



ATTACHMENT II.B.5  
STRUCTURE LOCATION MAP

Lines #2019 and #2007 Rebuild Project  
City of Virginia Beach, Virginia  
Owner/Applicant:  
Dominion Energy Virginia  
C2 Env Project: 0233 Prepared By: GCF Date: 07/19/22  
SHEET 2 OF 4

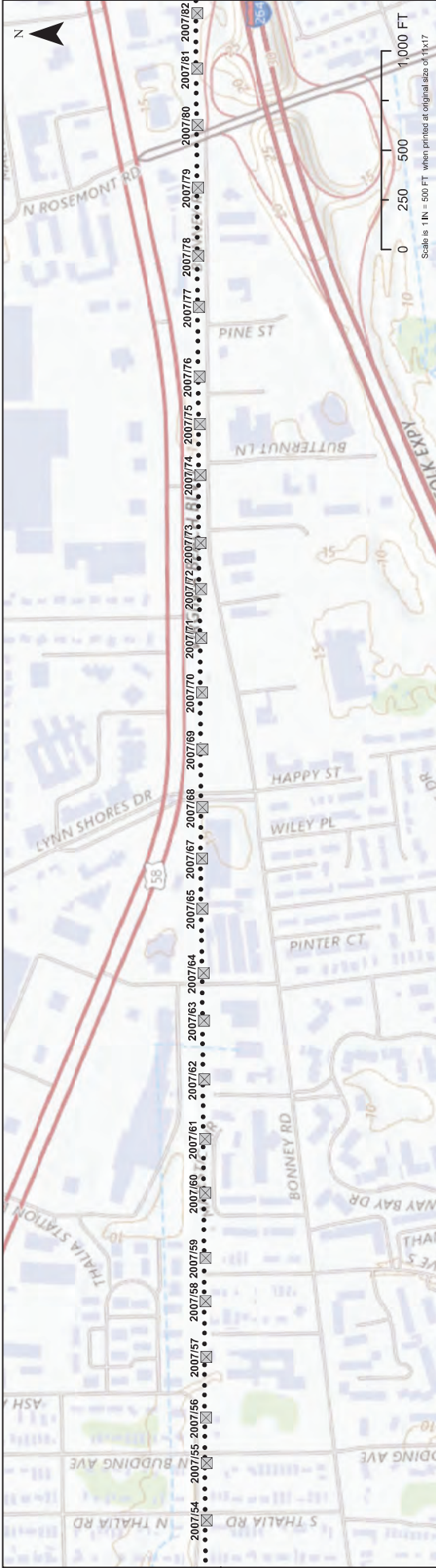
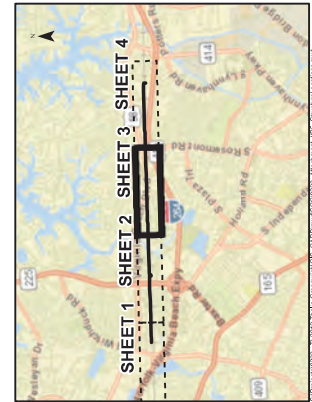

TABLE II.B.5

Structure Number	2007/54	2007/55	2007/56	2007/57	2007/58	2007/59	2007/60	2007/61	2007/62	2007/63	2007/64	2007/65	2007/67	2007/68	2007/69	2007/70	2007/71	2007/72	2007/73	
Existing Structure Height (Feet)	96	91	89	84	84	94	84	84	95	90	90	84	84	85	91	86	96	86	89	
Proposed Structure Height (Feet)	117	112	107	102	107	112	107	102	107	112	112	107	102	107	107	107	112	102	102	
Structure Number	2007/74	2007/75	2007/76	2007/77	2007/78	2007/79	2007/80	2007/81	2007/82											
Existing Structure Height (Feet)	93	94	94	84	84	94	90	84	85											
Proposed Structure Height (Feet)	102	102	102	102	92	107	107	92	102											

\*Existing structure not to be replaced

- Notes: 1. Structure locations and heights provided by Dominion Energy Virginia.  
 2. Existing structures are to be replaced in the same approximate location with proposed locations subject to final engineering. The proposed approximate structure heights are from the conceptual design created to estimate the cost of the Rebuild Project and are subject to change based on final engineering design. The proposed structure heights are above ground level. In addition to replacing existing structures, some new structures are proposed within the Thalia and Lynnhaven Substations, as illustrated above.  
 3. Basemap from ESRI Topographic and World Street Map.



SITE DATA

- Existing Line #2019 Project Centerline
- Existing Line #2007 Project Centerline
- ⊠ Existing Structure
- ⊠ New Structure
- ▲ Existing Substation



ATTACHMENT II.B.5  
 STRUCTURE LOCATION MAP

Lines #2019 and #2007 Rebuild Project  
 City of Virginia Beach, Virginia  
 Owner/Applicant:  
 Dominion Energy Virginia  
 C2 Env Project: 0233 Prepared By: GCF Date: 07/19/22  
 SHEET 3 OF 4

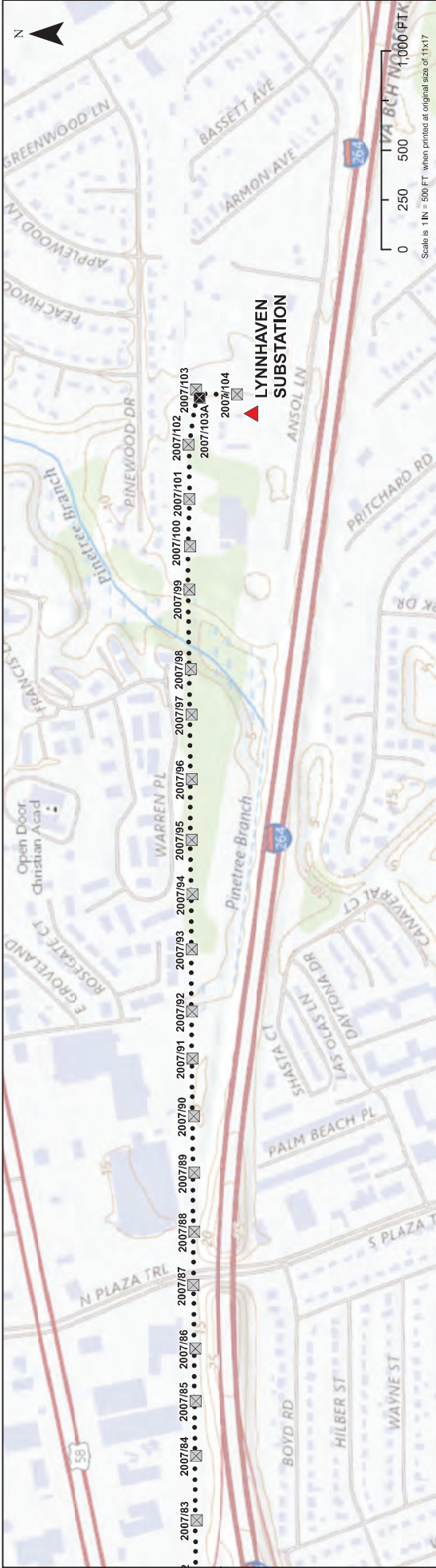
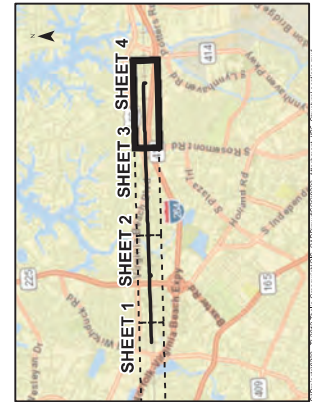

TABLE II.B.5

Structure Number	2007/83	2007/84	2007/85	2007/86	2007/87	2007/88	2007/89	2007/90	2007/91	2007/92	2007/93	2007/94	2007/95	2007/96	2007/97	2007/98	2007/99	2007/100	2007/101
Existing Structure Height (Feet)	94	82	93	93	95	86	86	87	89	90	84	84	84	94	90	94	84	84	90
Proposed Structure Height (Feet)	102	102	102	102	107	102	102	102	102	102	102	102	102	102	102	112	107	107	97
Structure Number	2007/102	2007/103A	2007/103*	2007/104*															
Existing Structure Height (Feet)	94	N/A	101	70															
Proposed Structure Height (Feet)	107	77	101	70															

\*Existing structure not to be replaced

- Notes: 1. Structure locations and heights provided by Dominion Energy Virginia.  
 2. Existing structures are to be replaced in the same approximate location with proposed locations subject to final engineering. The proposed approximate structure heights are from the conceptual design created to estimate the cost of the Rebuild Project and are subject to change based on final engineering design. The proposed structure heights are above ground level. In addition to replacing existing structures, some new structures are proposed within the Thalia and Lynnhaven Substations, as illustrated above.  
 3. Basemap from ESRI Topographic and World Street Map.



SITE DATA

- Existing Line #2019 Project Centerline
- Existing Line #2007 Project Centerline
- ⊠ Existing Structure
- ⊠ New Structure
- ▲ Existing Substation



ATTACHMENT II.B.5  
 STRUCTURE LOCATION MAP

Lines #2019 and #2007 Rebuild Project  
 City of Virginia Beach, Virginia

Owner/Applicant:  
 Dominion Energy Virginia

C2 Env Project:  
 0233

Prepared By:  
 GCF

Date:  
 07/19/22

SHEET 4 OF 4

## II. DESCRIPTION OF THE PROPOSED PROJECT

### B. Line Design and Operational Features

6. Provide photographs for typical existing facilities to be removed, comparable photographs or representations for proposed structures, and visual simulations showing the appearance of all planned transmission structures at identified historic locations within one mile of the proposed centerline and in key locations identified by the Applicant.

Response: [1] See Attachments II.B.6.a.i through II.B.6.a.iv for representative photographs of the existing structures.

[2] See Attachments II.B.6.b.i through II.B.6.b.iii for representative photographs of the proposed structures for the Rebuild Project.

[3] The overall increase in structure height between the existing and proposed structures does not meet the threshold of a “substantial increase” as outlined by the VDHR in *Guidelines for Assessing Impacts of Proposed Electric Transmission Lines and Associated Facilities on Historic Resources in the Commonwealth of Virginia* (January 2008); therefore, no photo simulations were prepared from historic properties.

See Attachment III.B.4 for visual simulations of key locations evaluated.



**Existing Structure Type:  
230 kV Single Circuit Concrete Monopole (I-String Suspension)**





**Existing Structure Type:  
230 kV Single Circuit Concrete Monopole (DDE - With Conductor Arms)**





**Existing Structure Type:**  
**230 kV Single Circuit Concrete Monopole (Floating DDE - With Conductor Arms)**



Attachment II.B.6.a.iii



**Existing Structure Type:  
230 kV Single Circuit Painted Steel Monopole (DDE - No Conductor Arms)  
Structures 2019/41 & 2007/42A**





**Proposed Structure Type:  
230 kV Single Circuit Steel Monopole (DDE - with Conductor Arms)**

Attachment II.B.6.b.i



**Proposed Structure Type:  
230 kV Single Circuit Steel Monopole (V-String Suspension)**



**Proposed Structure Type:  
230 kV Single Circuit Steel Monopole (DDE - No Conductor Arms)**

Attachment II.B.6.b.iii



## II. DESCRIPTION OF THE PROPOSED PROJECT

- C. Describe and furnish plan drawings of all new substations, switching stations, and other ground facilities associated with the proposed project. Include size, acreage, and bus configurations. Describe substation expansion capability and plans. Provide one-line diagrams for each.**

Response: There are no new substations, switching stations, or other ground facilities associated with the proposed Rebuild Project, nor are any of the impacted substations being expanded. The Rebuild Project will require the following station work:

At the Thalia Substation, the Company will replace Line #2019 and #2007 risers and upgrade line terminal equipment including one 4000A circuit breaker in the line tie position and four 4000A switches to support the new line rating. The Company will also remove wave traps at the Thalia Substation.

At the Greenwich Substation, the Company will replace Line #2019 risers and upgrade line terminal equipment including three 4000A switches to support the new line rating.

At the Lynnhaven Substation, the Company will replace Line #2007 risers and upgrade line terminal equipment including two 4000A circuit breakers and four 4000A switches to support the new line rating. The Company will also remove a wave trap at the Lynnhaven Substation.

### III. IMPACT OF LINE ON SCENIC, ENVIRONMENTAL AND HISTORIC FEATURES

- A. **Describe the character of the area that will be traversed by this line, including land use, wetlands, etc. Provide the number of dwellings within 500 feet, 250 feet and 100 feet of the centerline, and within the ROW for each route considered. Provide the estimated amount of farmland and forestland within the ROW that the proposed project would impact.**

Response: **Land Use**

The proposed Rebuild Project is located the City of Virginia Beach. The project area is largely characterized as urban, with residential and commercial development in the surrounding area.

#### **Farmlands/Forests**

According to the Natural Resources Conservation Service Data (“NRCS”), within the right-of-way there are approximately 1.3 acres of prime farmland and no areas of farmland of statewide importance. Prime farmland is an NRCS designation based on soil composition and is defined by the U.S. Department of Agriculture as land that has the best combination of physical and chemical characteristics for producing food, feed, forage, fiber, and oilseed crops, and is available for these uses. Farmland of statewide importance includes land that nearly meets the criteria for prime farmland and has been designated by the Virginia Department of Agriculture and Consumer Services and Virginia Department of Conservation and Recreation (“DCR”) as important for the production of food, feed, forage, fiber, and oilseed crops and that economically produces high yields of crops when treated and managed according to acceptable farming methods. Farmland classifications are not based on current land use. The right-of-way has been in use since the early 1930s and it is not expected that the Rebuild Project will permanently impact farmland since the area is fully developed or occupied by other infrastructure.

Prime farmlands within the Rebuild Project right-of-way are depicted in [Attachment III.A.1.](#)

#### **Wetlands**

The proposed Rebuild Project is located within the Lynnhaven-Poquoson watershed, Hydrologic Unit Code 02080108. According to the U.S. Geological Survey (“USGS”) topographic quadrangles (Kempsville [2019] and Princess Anne [2019], Virginia), the existing transmission line corridor crosses Thalia Creek and Pine Tree Branch.

The Company utilized aerial imagery, U.S. Fish and Wildlife Service (“USFWS”) National Wetlands Inventory, National Resources Conservation Service Soil Surveys, Federal Emergency Management Floodplain Mapping, and existing contour data to estimate jurisdictional wetlands and waters of the United States

within the proposed Rebuild Project right-of-way. Total jurisdictional resources within the Rebuild Project right-of-way, as estimated using desktop resources, are provided in the table below.

**Estimated jurisdictional resources within the Rebuild Project Right-of-Way**

<b>Resource</b>	<b>Area/Length (±)</b>
Palustrine Emergent/ Scrub Shrub Wetland	4.4 Acres
Estuarine Emergent/ Scrub Shrub Wetland	0.2 Acre
Non-Tidal Stream Channel	0.2 Acre / 1,807 Linear Feet
Tidal Stream Channel	0.1 Acre / 110 Linear Feet

Prior to construction, the Company will delineate wetlands and other waters of the United States using the *Routine Determination Method*, as outlined in the *1987 Corps of Engineers Wetland Delineation Manual* and methods described in the *2010 Regional Supplement to the Corps of Engineers Wetland Delineation Manual: Atlantic and Gulf Coastal Plain Region (Version 2.0)*. The Company will also obtain any necessary permits to impact jurisdictional resources.

**Historic Features**

In accordance with the *Guidelines for Assessing Impacts of Proposed Transmission Lines and Associated Facilities on Historic Resources in the Commonwealth of Virginia (2008)*, a Stage I Pre-Application Analysis was conducted by Dutton. This report was submitted to the VDHR on July 13, 2022, and is included as Attachment 2.I.2 to the DEQ Supplement. The table below summarizes the resources considered in the assessment.

**VDHR Guidelines for Impacts of Proposed Transmission Lines**

<b>Radial Buffer (in miles)</b>	<b>Considered Resources</b>
1.5	National Historic Landmarks
1.0	Above resources, and: National Register Properties (listed) Battlefields Historic Landscapes (e.g. Rural HD)
0.5	Above resources, and: National Register-eligible (as determined by VDHR)
0.0 (within ROW)	Above resources, and: Archaeological Sites

No National Historic Landmark (“NHL”)-listed architectural resources are located within the 1.5-mile radius of the Rebuild Project centerline. Three architectural resources that are listed on the NRHP are located within 1.0-mile of the Rebuild Project centerline. Two NRHP-eligible resources were identified within 0.5 mile of the Rebuild Project centerline.

Based upon the proposed changes to structure heights, dense development in the surrounding area, and scattered vegetation, it is anticipated that the Rebuild Project will have no impact to the majority of the historic resources. One historic resource, Norfolk and Virginia Beach Railroad, is located within the Rebuild Project right-of-way. The existing structures are clearly visible from within this resource, therefore, the proposed structures are expected to have no more than minimal impact on this resource.

**Previously Recorded Architectural Resources Considered under the Stage I Pre-Application Guidelines**

<b>VDHR #</b>	<b>Resource Name</b>	<b>VDHR/NRHP Status</b>	<b>Distance to Centerline</b>	<b>Impact</b>
134-0031	Francis Land House (Historic/Current), Rose Hall (NRHP Listing)	NRHP Listing, VLR* Listing	Within 1.0 mile	No Impact
134-0027	Pleasant Hall (Historic/Current)	NRHP Listing, VLR Listing	Within 1.0 mile	No Impact
134-0026	Pembroke Manor (NRHP Listing)	NRHP Listing, VLR Listing	Within 1.0 mile	No Impact
134-5145	Norfolk and Virginia Beach Railroad (Historic)	VDHR Staff: Eligible	Within 0.5 mile	Minimal Impact
134-5052	Center for Effective Learning Middle School (Current), Princess Anne Training School/Union Kempsville High School (Historic), Union Kempsville High School (Historic), Virginia Beach Central Academy High School (Current)	VDHR Staff: Potentially Eligible	Within 0.5 mile	No Impact

\*VLR stands for Virginia Landmarks Register

One recorded archaeological resource was identified within the Rebuild Project right-of-way; however, the resource has been determined not eligible for listing on the NRHP by VDHR.

**Previously Recorded Archeological Resources Considered under the  
Stage I Pre-Application Guidelines**

<b>VDHR #</b>	<b>Resource Name</b>	<b>VDHR/NRHP Status</b>	<b>Distance to ROW</b>	<b>Impact</b>
44VB0060	Kempsville Canal	DHR Staff: Not Eligible	0 mile	No impact

**Threatened and Endangered Species**

Online database searches for threatened and endangered species in the vicinity of the Rebuild Project, including the USFWS Information, Planning, and Conservation system, the Virginia Department of Wildlife Resources (“DWR”) Virginia Fish and Wildlife Information Service, DCR, Natural Heritage Data Explorer, and the Center for Conservation Biology Bald Eagle Nest Locator, were conducted, which identified federal- and state-listed species that have the potential to occur within the Rebuild Project right-of-way. These resources are identified in the report included as Attachment 2.G.1 to the DEQ Supplement. The Company intends to reasonably minimize any impact on these resources and coordinate with pertinent agencies, as appropriate.

**Dwellings**

According to a review of the most recent aerial imagery available in Google Earth, there are approximately 558 dwellings within 500 feet of the centerline of the Rebuild Project, 225 dwellings within 250 feet of the centerline, and 58 dwellings within 100 feet of the centerline. Multi-family dwellings are present throughout the area and are included as a single count per building where individual units could not be differentiated. No dwellings are located within the existing right-of-way.

ATTACHMENT III.A.1

**PRIME FARMLAND MAP**

Lines #2019 and #2007 Rebuild Project

City of Virginia Beach, Virginia

Owner/Applicant:

Dominion Energy Virginia

Prepared By: GCF

Date: 07/19/22

C2 Env Project: 0233

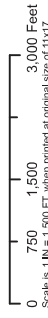

**LEGEND**

- Line 2019 Project Area
- Line 2007 Project Area
- Existing Structure 2019/20
- Existing Substation
- All Areas Are Prime Farmland (+/- 1.3 AC)

- Notes:
1. Basemap from ESRI World Imagery
  2. Project Area from GIS
  3. Project from VDOT
  4. Farmland from NRCS Soil Survey

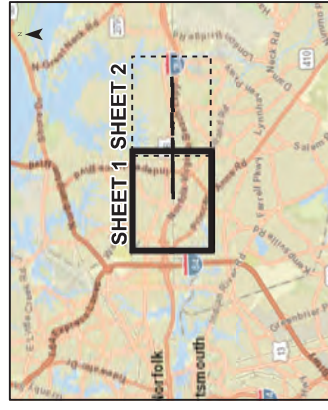

SHEET 1 OF 2

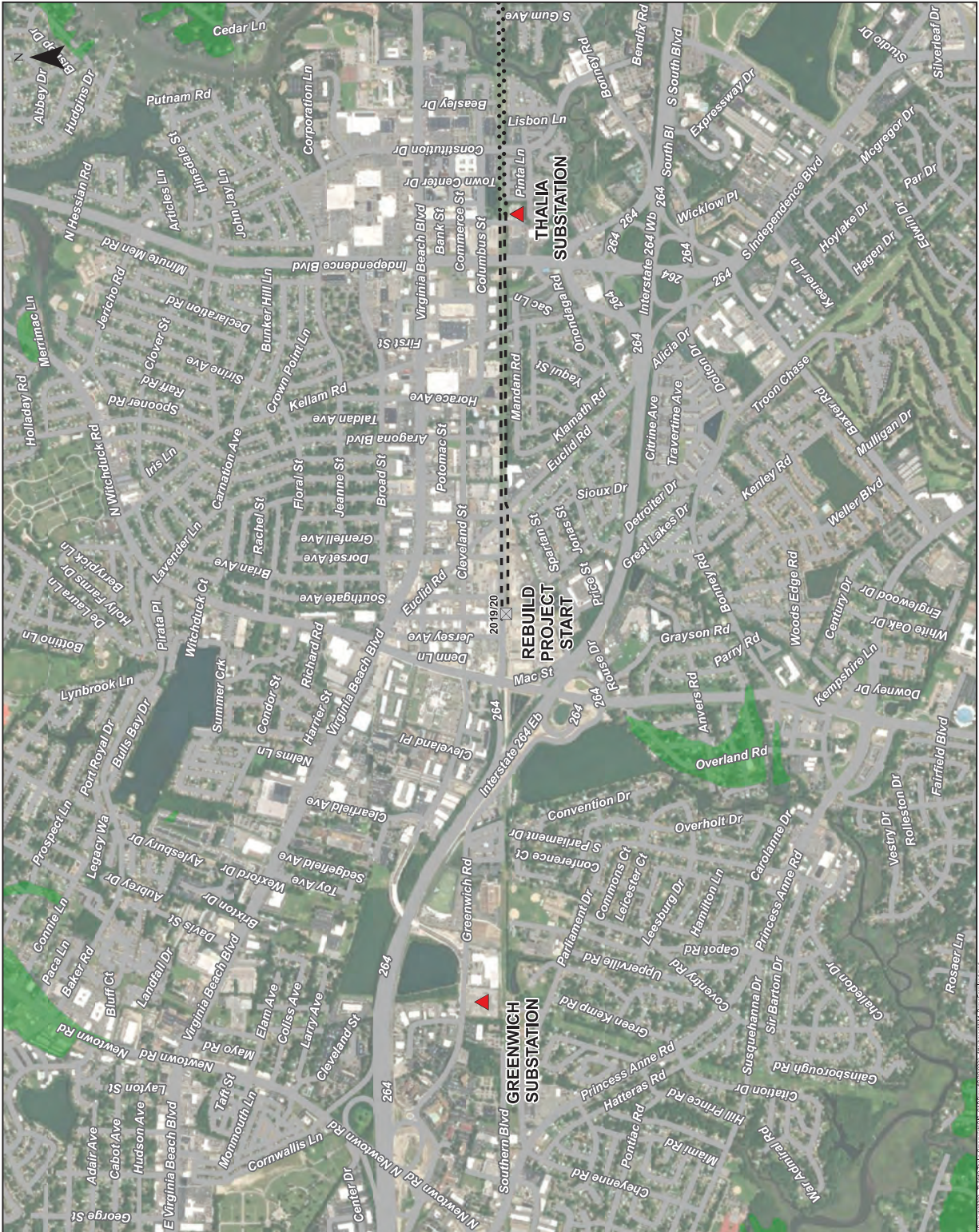

ATTACHMENT III.A.1

**PRIME FARMLAND MAP**

**Lines #2019 and #2007 Rebuild Project**

City of Virginia Beach, Virginia

Owner/Applicant:

Dominion Energy Virginia

Prepared By: GCF

Date: 07/19/22

0233

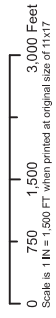

**LEGEND**

- Line 2019 Project Area
- Line 2007 Project Area
- Existing Structure 2019/20
- Existing Substation
- All Areas Are Prime Farmland (+/- 1.3 AC)

Notes:  
 1. Base map from ESRI World Imagery  
 2. Project boundary provided by Dominion  
 3. Roads from VDOT  
 4. Farmland from NRCS Soil Survey

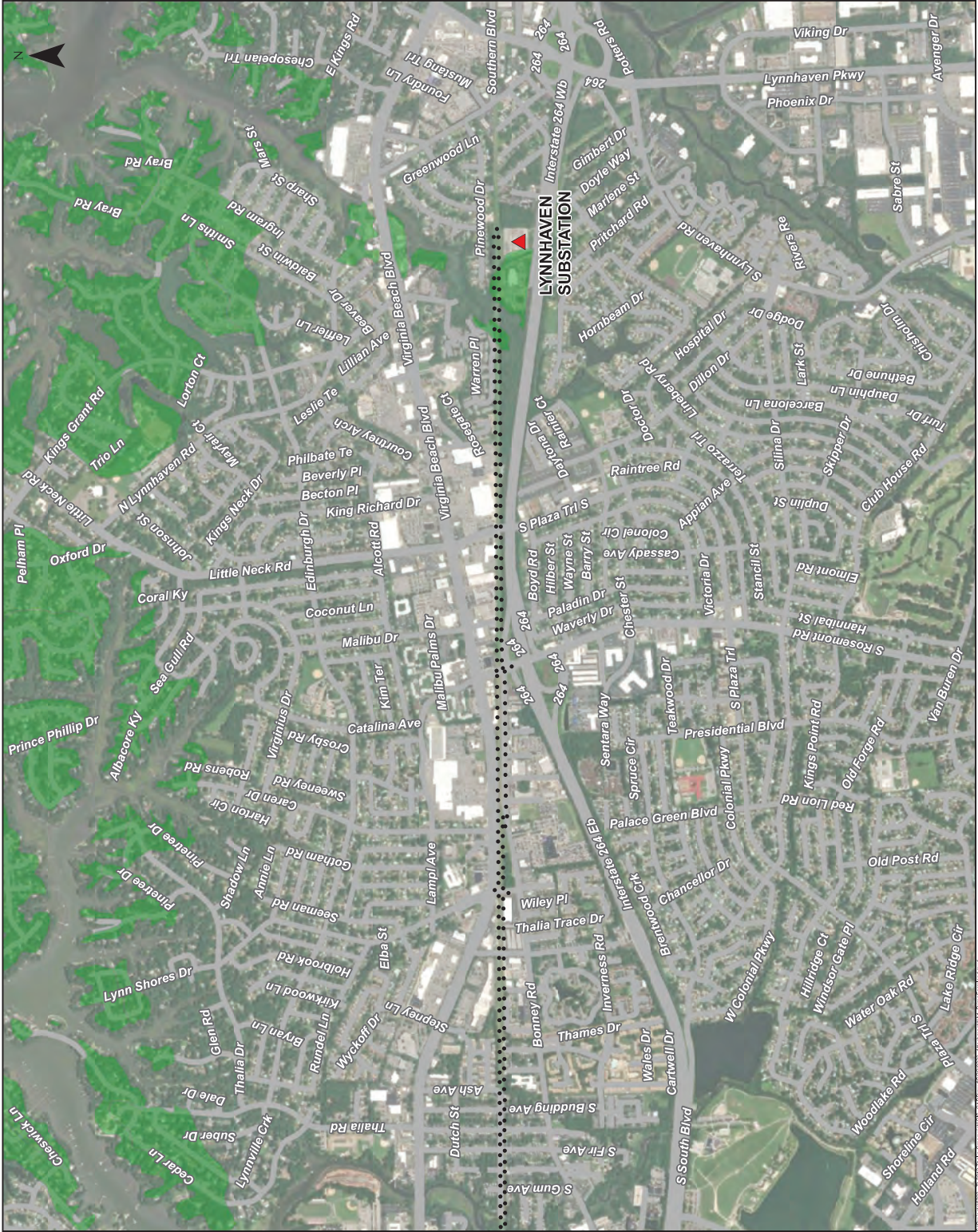
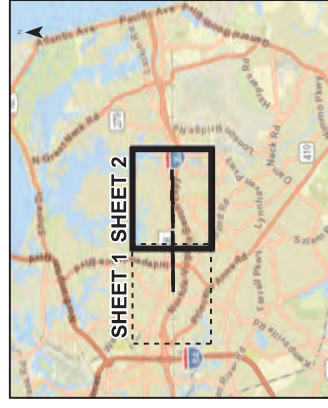

### III. IMPACT OF LINE ON SCENIC, ENVIRONMENTAL AND HISTORIC FEATURES

#### B. Describe any public meetings the Applicant has had with neighborhood associations and/or officials of local, state or federal governments that would have an interest or responsibility with respect to the affected area or areas.

Response: In April 2022, the Company launched an internet website dedicated to the proposed Rebuild Project: [www.dominionenergy.com/greenwich](http://www.dominionenergy.com/greenwich). The website includes a description and benefits of the proposed Rebuild Project, an explanation of need, route maps, photo simulations, a project overview video, and information on the Commission review process.

On June 30, 2022, the Company sent a project announcement postcard to 900 property owners within 500 feet of the Rebuild Project. Each postcard included information about the proposed Rebuild Project, an overview map, and an invitation to the virtual open house. The postcard provided a brief overview of the respective proposed Rebuild Project. Copies of the postcard are included as Attachment III.B.1.

Newspaper print advertisements regarding the Rebuild Project and virtual open house were placed in The Princess Anne Independent on July 3, 2022, and the Suffolk News Herald on July 7, 2022. A copy of the advertisement placed in Virginia Beach newspapers is included as Attachment III.B.2.

In addition, digital advertisements for the virtual open house, included targeted residents in Virginia Beach. Paid digital and social media campaigns were also used to drive awareness of Dominion Energy Virginia's Rebuild Project and the virtual community meeting to educate the public. A copy of those digital advertisements are included as Attachment III.B.3.

The event campaigns ran within Google AdWords, Google Display, Google Video, Facebook and Twitter. All phases urged local residents to visit the [www.dominionenergy.com/greenwich](http://www.dominionenergy.com/greenwich) website to learn more about the meeting and to participate virtually.

The Greenwich Thalia Lynnhaven Pre-Event campaigns ran from July 8, 2022 to July 14, 2022. The campaigns targeted audiences in Virginia Beach.

Pre-event digital ads generated 655,610 impressions and 13,131 link clicks. There were 107,974 video views with an average 8.34% average video completion rate and the digital ads had a 2.52% click thru rate.

The Greenwich Thalia Lynnhaven post-event campaigns ran from July 20, 2022 to July 27, 2022. The campaigns targeted audiences in Virginia Beach.

Post-event digital ads generated 461,030 impressions and 18,161 link clicks. There

were 102,148 video views with an average 6.96% video completion rate and the digital ads had a 4.41% click thru rate.

One virtual community meeting was held on July 14, 2022, from 5:00-6:00 p.m. At the virtual open house, the Company made available details about construction, project timing, and the Commission approval process. Traditional open house materials have been posted on the website for the proposed Rebuild Project, including simulations of the proposed Rebuild Project from key locations. The key location simulations are included as Attachment III.B.4.

In addition to the simulations, the Company also made available a tool commonly referred to as the Backyard Application, which is a structure height comparison tool. This tool allows residents who live near the Rebuild Project area to compare the height of current structures with the height of proposed structures. A screenshot of this tool is included as Attachment III.B.5.

As part of preparing for this Rebuild Project, the Company researched the demographics of the surrounding communities using 2020 U.S. Census data. This information revealed that there are 55 Census Block Groups (“CBGs”) within the Rebuild Project area that fall within one mile of the existing transmission line corridor. A review of ethnicity, income, age, and education census data identified populations within the study area that meet the Virginia Environmental Justice Act threshold to be defined as Environmental Justice Communities (“EJ Communities”). Communities of color have been identified in 33 of 55 CBGs within the one-mile search area. Thirty-two of 55 CBGs within the one-mile search area appear to be low-income. Eight CBGs are directly crossed by the route of the Rebuild Project, seven of which are low-income communities of color.

Pursuant to Va. Code §§ 56-46.1 C and 56-259 C, as well as in Attachment 1 of these Guidelines, there is a strong preference for the use of existing utility right-of-way whenever feasible. The Rebuild Project is within the existing right-of-way and will not require any of the following: additional permanent or temporary right-of-way, the construction of a temporary line, or an increase in operating voltage. The structural height average will increase by 15 feet from 88 feet to 103 feet. Height differences will vary per structural location. Based on the analysis of the Rebuild Project, the Company does not anticipate disproportionately high or adverse impacts to the surrounding community and the EJ Communities located within the study area, consistent with the Rebuild Project design to reasonably minimize impacts.

In addition to its evaluation of impacts, the Company has and will continue to engage the EJ Communities and others affected by the Rebuild Project in a manner that allows them to meaningfully participate in the project development and approval process so that their views and input can be taken into consideration. See Attachment III.B.6 for a copy of the Company’s Environmental Justice Policy.

Electric Transmission  
P.O. Box 26666  
Richmond, VA 23261



**Dominion  
Energy**

Actions Speak Louder

**YOU'RE INVITED TO  
A VIRTUAL COMMUNITY MEETING!  
DETAILS ENCLOSED**



Dominion Energy image. Not project specific.

## IMPORTANT

# Local Power Line Project Information

## Greenwich-Thalia-Lynnhaven 230 kV Electric Transmission Line Rebuild Project — Virtual Community Meeting

Use your iPhone camera or the QR reader app on other smartphones to visit the project page on our website.



AT DOMINION ENERGY, we are committed to continually reviewing and analyzing our energy infrastructure to provide safe, reliable electricity to our neighbors.

We are planning to replace a 230 kV electric transmission line located in Virginia Beach, to maintain reliable service for our customers. Construction will occur along a five-mile corridor and remain within the existing right of way while crossing Interstate 264 and South Independence Boulevard.

This project is necessary to replace aging equipment and maintain reliable service for our customers. After nearly five decades of reliable service, the structures and related components are at the end of their service life and need to be replaced to ensure reliable operation of the transmission line.

Rebuilding the line will allow Dominion Energy to continue to comply with mandatory standards that ensure continued safety of the electric grid.

We invite you to participate in a virtual community meeting July 14, 2022, to learn more about this project, our construction plans, and meet our team.

Please know that we are dedicated to working safely and courteously in your community and we will continue to keep you updated on our progress.

## CONTACT US

Visit our website at [DominionEnergy.com/greenwich](https://www.DominionEnergy.com/greenwich) for project updates. Or contact us by calling 888-291-0190 or sending an email to [powerline@dominionenergy.com](mailto:powerline@dominionenergy.com).



This map is intended to serve as a representation of the project area and is not intended for detailed engineering purposes.

## VIRTUAL COMMUNITY MEETING

Live Via Webex Events

Thursday, July 14, 2022 • 5 – 6 p.m.

Join the meeting by visiting our website, [DominionEnergy.com/greenwich](https://www.DominionEnergy.com/greenwich)

A recording will be available on the project website after the meeting.

AT DOMINION ENERGY, protecting the grid and making it secure against natural and man-made acts is a top priority. We work alongside government officials to prepare for potential incidents that could affect our ability to provide electricity safely and reliably to the communities we serve. Learn how we're keeping you safe at [powerlines101.dominionenergy.com](https://www.powerlines101.dominionenergy.com).

**Dominion Energy  
Electric Transmission**

Greenwich-Lynnhaven  
Pre Event Newspaper

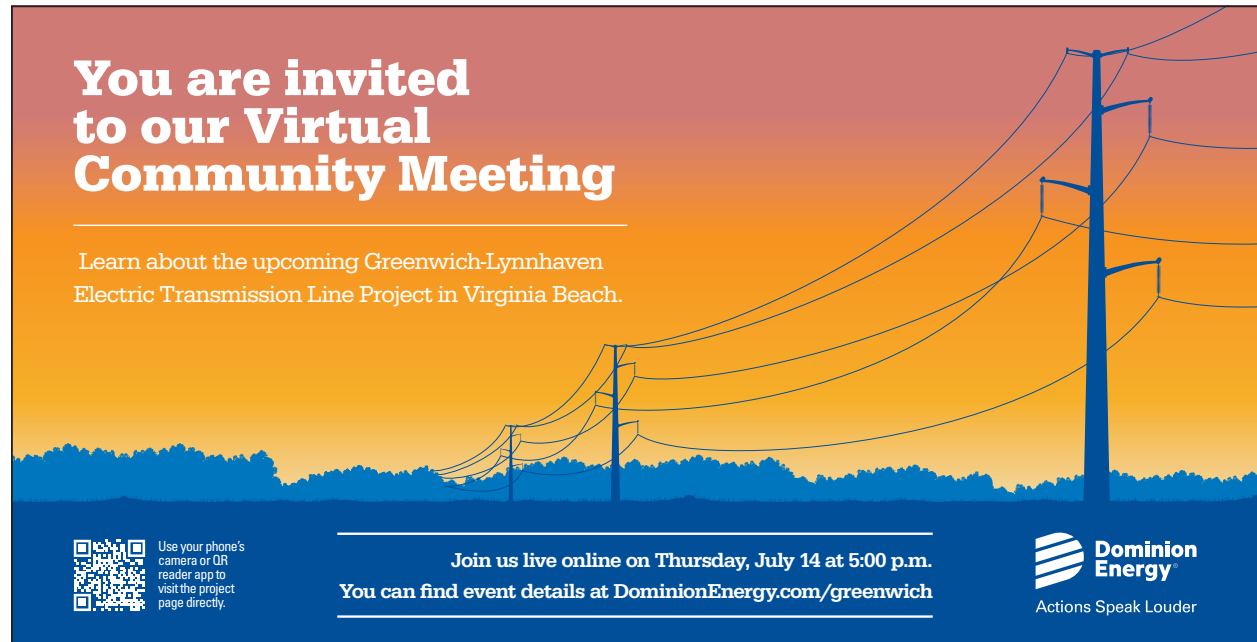

**You are invited  
to our Virtual  
Community Meeting**

Learn about the upcoming Greenwich-Lynnhaven  
Electric Transmission Line Project in Virginia Beach.

Use your phone's  
camera or QR  
reader app to  
visit the project  
page directly.

Join us live online on Thursday, July 14 at 5:00 p.m.  
You can find event details at [DominionEnergy.com/greenwich](https://www.dominionenergy.com/greenwich)

 **Dominion  
Energy**  
Actions Speak Louder

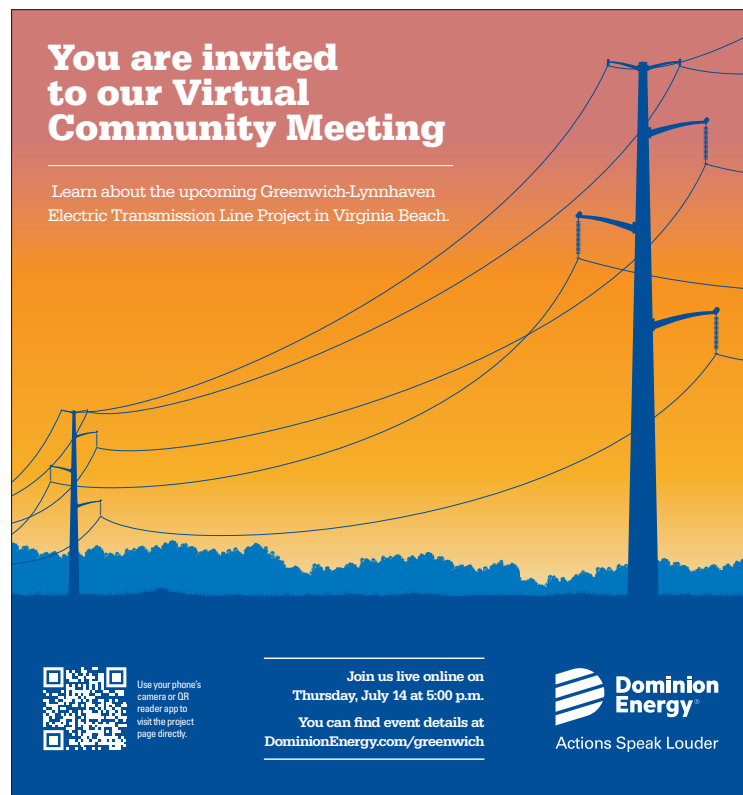

**You are invited  
to our Virtual  
Community Meeting**

Learn about the upcoming Greenwich-Lynnhaven  
Electric Transmission Line Project in Virginia Beach.

Use your phone's  
camera or QR  
reader app to  
visit the project  
page directly.

Join us live online on  
Thursday, July 14 at 5:00 p.m.  
You can find event details at  
[DominionEnergy.com/greenwich](https://www.dominionenergy.com/greenwich)

 **Dominion  
Energy**  
Actions Speak Louder

**Dominion Energy  
Electric Transmission**

Greenwich-Lynnhaven  
Awareness Display

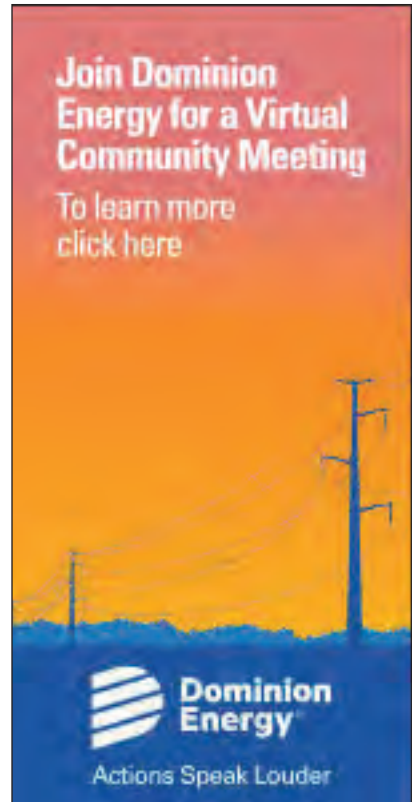
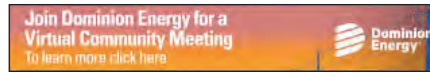

**Dominion Energy  
Electric Transmission**

Greenwich-Lynnhaven  
Awareness Post-Event  
Display

Watch a recording of our Virtual Community Meeting  
Learn more about plans for transmission line infrastructure in your area



Watch a recording of our Virtual Community Meeting  
To learn more click here



Watch a recording of our Virtual Community Meeting  
Learn more about infrastructure plans



Watch a recording of our Virtual Community Meeting  
To learn more click here



Watch a recording of our Virtual Community Meeting  
Learn more about plans for transmission line infrastructure in your area



Watch a recording of our Virtual Community Meeting  
Learn more about plans for transmission line infrastructure in your area



**Dominion Energy  
Electric Transmission**

Greenwich-Lynnhaven  
Nextdoor Imagery

Event Post Image:



Post-Event Post Image:



**Dominion Energy  
Electric Transmission**

Greenwich-Lynnhaven  
Event Social Videos

[Pre-Event Video \(Click to play\)](#)



[Post-Event Video \(Click to play\)](#)



# GREENWICH - THALIA - LYNNHAVEN

## 230kV Rebuild



- ① PHOTO VIEWPOINT
- ▲ EXISTING SUBSTATIONS
- BEGIN REBUILD PROJECT
- EXISTING TRANSMISSION LINE STRUCTURES TO REMAIN - NEW FO COMMUNICATIONS ONLY (SEE NOTE 1)
- EXISTING TRANSMISSION LINE TO BE REBUILT

NOTE 1: VISUAL CHANGES FROM THE NEW FIBER OPTIC (FO) COMMUNICATIONS CABLES ARE NEGLIGIBLE. NO PHOTO SIMULATIONS HAVE BEEN PROVIDED FOR THIS SEGMENT.

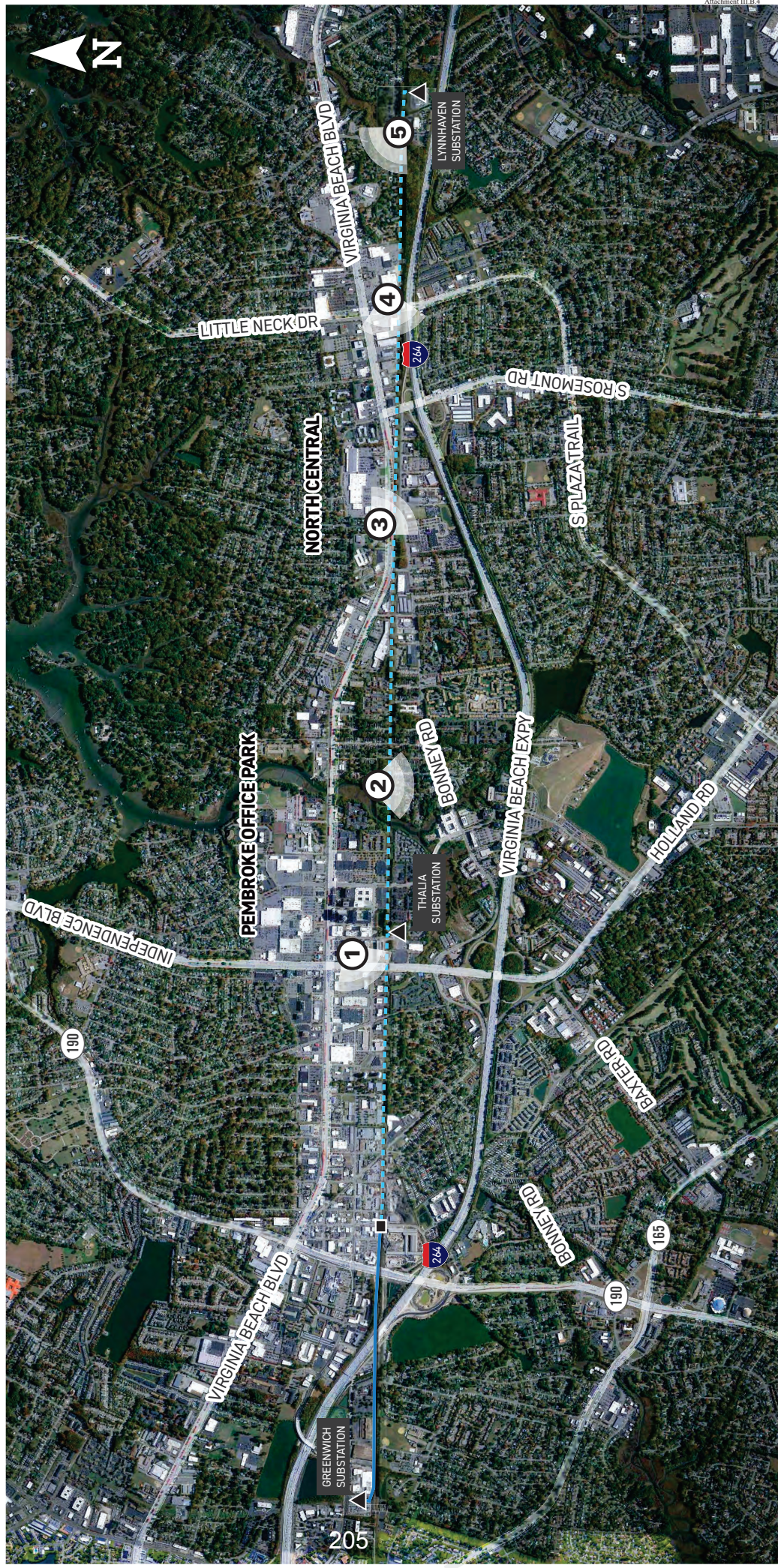



**EXISTING** Conditions



**PROPOSED** Conditions

Photo simulations are for discussion purposes only. Final design is subject to change pending public engineering and regulatory review.



- ①
- ▲
- 
- 
- ■

**PHOTO VIEWPOINT**  
**EXISTING SUBSTATIONS**  
**BEGIN REBUILD PROJECT**  
**EXISTING TRANSMISSION LINE STRUCTURES TO REMAIN - NEW FO COMMUNICATIONS ONLY (SEE NOTE 1)**  
**EXISTING TRANSMISSION LINE TO BE REBUILT**

**SIMULATION 1**

Date: 5/18/22  
 Time: 12:48pm  
 Viewing Direction: Southwest

**GREENWICH - THALIA - LYNNHAVEN**  
 230kV Rebuild





**EXISTING** Conditions



**PROPOSED** Conditions

207

Photo simulations are for discussion purposes only. Final design is subject to change pending public engineering and regulatory review.

- ② PHOTO VIEWPOINT
- ▲ EXISTING SUBSTATIONS
- BEGIN REBUILD PROJECT
- EXISTING TRANSMISSION LINE STRUCTURES TO REMAIN - NEW FO COMMUNICATIONS ONLY (SEE NOTE 1)
- ⋯ EXISTING TRANSMISSION LINE TO BE REBUILT



**SIMULATION 2**

Date: 5/18/22  
 Time: 12:15pm  
 Viewing Direction: South

**GREENWICH - THALIA - LYNNHAVEN**  
 230kV Rebuild





**EXISTING** Conditions



**PROPOSED** Conditions

Photo simulations are for discussion purposes only. Final design is subject to change pending public, engineering, and regulatory review.

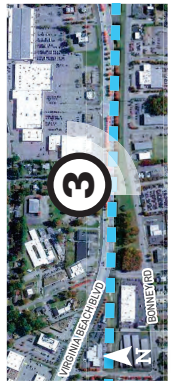

- ③ PHOTO VIEWPOINT
- ▲ EXISTING SUBSTATIONS
- BEGIN REBUILD PROJECT
- EXISTING TRANSMISSION LINE STRUCTURES TO REMAIN - NEW FO COMMUNICATIONS ONLY (SEE NOTE 1)
- ⋮ EXISTING TRANSMISSION LINE TO BE REBUILT

**SIMULATION 3**

Date: 5/18/22  
 Time: 11:49am  
 Viewing Direction: Southeast

**GREENWICH - THALIA - LYNNHAVEN**  
 230kV Rebuild

