



Electric Service and Meter Installations Manual

© Dominion Energy South Carolina, Inc. 2019

Revised: April 2019
On file with Public Service Commission of South Carolina

Table of Contents

Section 1: Introduction

Customer Call Centers 1
Engineering Assistance Offices..... 1
Definitions 1

Section 2: General Information

General 5
Availability and Classification of Service 6
Line Extensions 6
Temporary Service/Saw Service 7
Manufactured (Mobile Home) Service 9
Number of Services and Meters 9
Application for Service..... 10
Alterations and Additions..... 10
Use of Service by Customer..... 10
Interruption of Service and Liability 11
Grounding 11
Final Connections 12
Inspections 12
Meter Tampering, Seals and Fraudulent Use..... 13

Section 3: Overhead Service

General 15
Service Conductors – Attachment Point..... 15
Service Entrance General 15
Service Entrance Conductors..... 16

Section 4: Underground Service

General 19
Service Entrance Conductors..... 19
Underground Service in Overhead Districts 20
Underground Services from Underground Distribution..... 21
Underground Services in Underground Network Area 21

Section 5: Meter Installations

General Requirements 23
Metering Equipment Guide..... 24
Meter Location – General..... 25
Meters Located Outdoors..... 25
Meters Located Indoors..... 26
Mounting of Meters 27
Grouped Meters 27
Meter Wiring..... 28
Freestanding Switchboards..... 30
Additional Notes on Metering Facilities 30

Section 6: Service Equipment

Location..... 32
Interrupting Capacity of Protection Devices 32
Single Phase Service Equipment..... 32
Three Phase Service Equipment..... 33

Section 7: Transformer Vaults and Underground Primary Services

Vaults General 34
Underground Primary Services 34
Customers' Vault..... 35

Section 8: Power and Special Equipment Installations

Motors – General 36
Small Motors – 20 Horsepower and Below 36
Large Motors – General Above 20 Horsepower 37
Motor Starting Requirements – Above 20 Horsepower to 100 38
Motors Above 100 Horsepower..... 38
Special Equipment 41

Section 9: Supplementary Information and Drawings

Standard Voltages and Corresponding Demand Limitations..... 43
Standard Service Characteristics 44
Drawings 46

Section 1: Introduction

Customer Call Centers

You can reach our 24-hour Customer Service Center toll-free at **1-800-251-7234**.

Engineering Assistance Offices

Engineering assistance is available through the Customer Call Center.

Definitions

1. **"Application for Service"** - a mail, phone or personal request by the customer to the Company stating desire for electric service to be furnished at a certain location.
2. **"Building"** - a structure which stands alone or which is cut off from adjoining structures by firewalls, as defined by the pertinent building codes, with all openings therein protected by approved fire doors.
3. **"Class of Service"** - the characteristics of electric service described in terms of voltage, phase, frequency and number of wires.
4. **"Code"** - the National Electrical Code (NEC) and the National Electrical Safety Code or other electrical codes or regulations in effect in the area served.
5. **"Company, our, we, us"** - Dominion Energy South Carolina, Inc. ("Dominion Energy South Carolina") ("DESC").
6. **"Cost" or "expense"** - shall include all labor, material and other applicable charges, plus overheads.
7. **"Customer"** - either a present or a prospective user of the Company's electric service.
8. **"Customers' Installation"** - all wiring, conduit, service disconnecting devices, appliances, lighting, and other equipment installed and owned by the customer on his premises for his use.
9. **"Customer will provide" or "will install" or "will have installed" or "will furnish"** and similar references - the Company expects the customer to provide and install the equipment in question. It is assumed that the customer will delegate this obligation to

his bona fide agents. Actual electrical work and the furnishing of required materials are usually delegated to an electrician or an electrical contractor, and any structural work required to provide adequate attachment space or to attach racks for service wires is usually delegated to the general contractor.

10. "**Developer**" - the party entering into the agreement with the Company.
11. "**Distribution Lines**" - company lines located in or along streets, alleys, highways, rear lot lines or elsewhere, and by easements, when used or intended for use for general distribution of electric service to customers.
12. "**Electrical installation**" - the total electrical wiring and equipment installed on the customer's premises.
13. "**Firewall**" - a four-hour fire-resistant wall having protected openings, which restrict the spread of fire, and extend continuously from the foundation to three feet above the roof unless the roof is of non-combustible material for the area within forty feet (40') each side of the wall. In this case, the firewall need not extend above the roof.
14. "**Fraudulent Use**" - obtaining electric and/or gas service by unlawful means.
15. "**Ground**" - a conducting connection between an electric circuit, or equipment, and earth, or some conducting body, which serves in place of the earth.
16. "**Instrument Transformer**" - transformers used for reducing the current or voltage to quantities suitable for metering. There are indoor and outdoor types. Indoor types must be installed in cabinets whether installed indoors or outdoors. Outdoors types are usually installed without cabinets but may sometimes be put in cabinets.
17. "**Instrument Transformer Cabinet**" - a sealable metal box for housing instrument transformers, i.e., CT enclosure.
18. "**Line**" - a system of poles, wires, and fixtures, or the equivalent ducts, conduits, cables, etc. used for the distribution of electricity. It may be located in a street, highway, alley, or on a private right-of-way.
19. "**Line Extension**" - any addition to the Company's existing distribution lines and facilities which must be made to render electric service to a customer.
20. "**Manufactured Home**" - formerly known as a mobile home which has been

specifically designed to meet HUD provisions. For information pertaining to electrical service attached to the manufactured home, see article 217, "Manufactured (Mobile Home) and Trailer Service.

21. "**Meter**" - a device for measuring the electric power and energy supplied to a customer.
22. "**Meter Enclosure**" - a wood or metal cabinet, or metal socket, installed indoors or outdoors, in which the Company's metering equipment is located.
23. "**Meter Sockets**" - a meter socket is the base portion of a socket type meter. There are numerous kinds of meter sockets such as light duty, heavy duty, multi-terminal, etc. all with various numbers and sizes of conduit openings. Each particular socket has a preferred application although some are interchangeable.
24. "**Meter Tampering**" - any attempt to alter the registration of use on an electric or gas meter.
25. "**Mobile Home**" – See "Manufactured Home".
26. "**Modular Home**" - any building including the necessary electrical, plumbing, heating, ventilating and other service systems manufactured off site and transported to the point of use for installation or erection with or without other specified components, as a finished building and not designed for ready removal to another site. This must qualify under the S.C. Modular Building Construction Act, Regulation #19-460.15. Any home considered being a modular home will have a certification label. This label verifies it is a modular home and must be shown to the service representative before any electrical connection is made.
27. "**Overhead Distribution Areas**" - those areas in which the customer's premises abut on company overhead distribution facilities.
28. "**Point of Attachment**" - the first point of contact on the customer's building or structure at which the service drop is attached.
29. "**Rate Schedule Classification**" - the classification of the customer's electric service for rate application as determined by the class of service, the amount of electric power supplied and the purpose for which the electric service is to be used.
30. "**Service**" - the conductors and equipment for delivering energy from the Company's line to the wiring system of the premises served.

- A. **"Service drop"** - that portion of the overhead conductors between the Company's distribution line and the first point of attachment on the customer's facilities.
 - B. **"Service lateral"** - a system of underground conductors and equipment for delivering electricity from the Company's distribution system to the wiring system of a building or premises.
 - C. **"Service entrance"** - that part of the wiring from the point of attachment or termination of the service drop or service lateral to and including the service equipment on the customer's premises.
 - D. **"Service equipment"** - the necessary disconnecting and protective equipment, usually consisting of a circuit breaker or a switch and fuses and their accessories, owned by the customer, located near the point where the service entrance conductors enter a building and intended to constitute the main control and means of cutoff for the supply to that building.
31. **"Service connection"** - one service drop or service lateral and its associated service entrance.
32. **"Service entrance conductors"** - the supply conductors, which extend from the point of attachment or termination of the service drop or service lateral to the service equipment on the premises being served.
33. **"Service Entrance Equipment"** - the service entrance conductors, raceway and fittings or service entrance cable and fittings which are installed on the customer's premises to connect the electric service to the wiring inside the building.
34. **"Service Raceway"** - the conduit containing the service entrance conductors.
35. **"Shall"** - mandatory in nature.
36. **"Temporary or seasonal service"** - may be furnished under the appropriate General Service Rate Schedule to any Customer. Temporary service shall include all construction services and other services having a life expectancy of one year or less. Payment is required in advance for the full cost of erecting and removing all lines, transformers, and other service facilities necessary for the supply of such service.

Section 2: General Information

General

201. IT IS ALWAYS NECESSARY TO REFER TO AND COMPLY WITH STATUTES, UTILITY COMMISSION RULES AND LOCAL ORDINANCES. THE INFORMATION CONTAINED HEREIN IS GENERAL AND DOES NOT INCLUDE EVERY DETAIL OR EVERY LAWFUL REQUIREMENT.
202. This booklet is issued as a convenient general reference for customers, architects, engineers and contractors planning or constructing buildings or installing, repairing or renewing apparatus or equipment to be connected to the Company's distribution system.
203. These practices are subject to additions and changes at any time as developments and progress in the electrical industry may require. A copy of subsequent approved changes will be furnished each holder of this manual upon request.
204. The information herein is supplementary to the National Electrical Code and the National Electrical Safety Code, as approved by the American National Standards Institute, and such state and municipal laws and ordinances as may be in force within cities, towns or communities in which the Company furnishes electric service. Should a conflict exist, the authority having jurisdiction will govern.
205. The Company is desirous of serving its customers promptly and satisfactorily. It will endeavor to cooperate with contractors and customers to the fullest extent in completing service connections with as little delay and inconvenience as possible and will gladly give special attention to any particularly difficult situation confronting a customer.
206. The Company will be willing to confer, upon request, with those desiring information concerning rates, services, etc.
207. It is realized that the same or similar statements are repeated at various places in this booklet, but is intentional for emphasis and also because reference may be made to only a certain section for specific information and thus important factors may be overlooked if they are not repeated.

Availability and Classification of Service

208. The Company's nominal secondary service voltages are 120 volts single phase, 120/240 volts, 3 wire single phase, 240 volts 3 phase 3 wire, 120/240 3 phase 4 wire, 120/208 3 phase 4 wire, 277/480 volts 3 phase 4 wire. Service voltages higher than 480 volts are available only by negotiation with the company. The size and type of the customer's load must warrant such an installation. It is unusual for the Company to have more than one of these voltages available at any one location, and it must not be assumed that any particular voltage is available at any particular location. All of the above voltages are supplied at approximately 60 hertz. The customer must ascertain from the Company with absolute certainty, well in advance of the date actual service connection is required, whether or not the type of service required is available in the particular locality in question. If required service is available, its exact character must be determined; that is, the voltage, phase, etc. THESE CHARACTERISTICS MAY VARY IN DIFFERENT LOCALITIES. The Company will supply this information, and it is advisable to obtain it in writing so as to avoid possible misunderstandings. Do not rely on the representations of unauthorized parties. It is desirable to know the names of the Company representatives you deal with.
209. The information contained in this booklet refers primarily to service requirements at the usual secondary distribution voltages for light and power installations. Service requirements for installations requiring higher voltages are subject to special negotiation between the customer and the Company.
210. The Company will, if requested, advise and assist its present or prospective customers relative to problems associated with electrical equipment and facilities and particularly in the application of motors to the loads that are to be served.

Line Extensions

211. In order to avoid delay, persons desiring service are advised to inquire of the Company as to what type service may be provided, and to make necessary arrangements prior to beginning wiring installation.
212. Developers of subdivisions or other real estate projects are urged to consult with the Company as soon as preliminary plans are made, in order that the electric line extensions may be developed for the best possible arrangement, and right-of-way obtained before any lots are sold. The company can often suggest minor changes in lot lines so that poles, guy wires, pad-mount transformers, switchgear, etc. might

be avoided in undesirable locations. The Company is able to offer Underground Distribution in certain areas and details must be worked out in advance with the Customer Service Engineering Department or the District Manager of the Company (See Section 4).

Temporary Service/Saw Service

213. When temporary service is desired, the prospective customer will make arrangements for it directly with the Company at his local office, well in advance of the required service date. Prospective customers will contact the Company to have the service location spotted before construction is started. The Company reserves the right to refuse to connect a service without modification if a spot has not been requested.
214. Temporary installations requiring special service, meter or other work for construction purposes, exhibits of short duration etc., are made at the expense of the customer, with charges according to the material and work required for installing and removing. In all such cases, an advance payment sufficient to cover the estimated construction expense and energy used may be required. In those areas where Underground Distribution is to be established, special conditions relative to the establishment of temporary service will arise and must be worked out with the Customer Service Engineering Department or District Manager of the Company.
215. These services are usually overhead for construction purposes. They must be given special consideration since they are not of a permanent nature. In residential or commercial areas where underground distribution exists or is planned, special construction techniques are required. The following are the general steps to be taken by the customer in acquiring temporary or saw service.

STEP 1 - Applicant shall provide and erect a "Temporary Service Assembly" in accordance with the drawings, depending on whether the temporary service is in the underground or overhead area. The "Overhead Assembly" shall be installed at the job site not more than 125 feet from and facing the Company's nearest pole carrying suitable secondary wires. The "Underground Assembly" shall be installed as specified. The customer shall obtain a release from the local inspecting authority, if required, for each "Temporary Service Assembly."

STEP 2 - The customer shall make application for service at the Company's

nearest Customer Service office paying the required connection charge and/or service deposit. (This must be done at least three days before the date service is required.)

EXCEPTIONS TO STEPS 1 & 2

In cases where the Company's facilities are not within 125 feet or applicant is unable to determine whether or not the Company's facilities are suitable, then he should call the Company's office and request that an investigation be made as to the availability of temporary service. The investigator will advise the applicant if the service is readily available and where to install the "Temporary Service Assembly". In the event that the service is not readily available, a longer time may be required in order to make the necessary line extensions. Once the customer has satisfied the requirements of Step 1, he should proceed with Step 2.

Step 3 - The Company's service crews will come to the job site and make the connections if the "Assembly" is properly located and erected. If the "Assembly" is improperly installed, the applicant will be notified what corrections are necessary, and Step 4 will then become applicable.

Step 4 - Applicant shall have the necessary corrections made then notify the Company's nearest Customer Service office that the "Temporary Assembly" is ready for the establishment of service. An additional connection charge for the service crew's second call will be made. This step, including the additional connection charge, will be repeated for each trip the service crew makes and is unable to complete the connection if due to improper location or installation of the "Temporary Service Assembly".

NOTE: Each change of location of the “Temporary Service Assembly” shall be considered a new application for service and shall be governed by the rules above.

NOTE: If providing temporary service requires the Company to install transformers and other facilities which must be removed when temporary service is no longer required, then the customer may be required to pay the cost of installing and removing the Company’s temporary

facilities.

216. The customer must provide a suitable support for the service drop wires, meter and weatherproof housing for the service equipment. Service entrance wiring and equipment will be supplied and installed by the customer and at the location designated by the Company's representative. The temporary installation must meet the above criteria and be able to support the weight of a ladder with a person on it.

Manufactured (Mobile Home) Service

217. Owners of permanent or transient parking facilities should consult with the Customer Service Engineering Department or District Manager of the Company to find out how service will be provided. All installations shall be in accordance with the latest approved National Electrical Code, Article 550, and latest Company requirements. An electric meter can be attached to a manufactured (mobile) home if the conditions below are met:

- Local code inspector approves service.
- Company requirements are met (for overhead service, see drawings 06.03-03A, 06.03-03B and 06.03-03C; for underground service, see drawing 06.04-03A).
- Letter from home manufacturer certifying the manufactured home meets requirements for attaching service equipment.

Company has the right to reject any service found to be unsafe. Services could be declared unsafe due to electrical or structural issues. Structural issues occur most often on overhead installations – the installation not providing adequate support for the tension of the service conductors. The customer assumes all responsibility for damages resulting from attachment of service to a manufactured (mobile) home. Customer will be responsible for cost of lift pole if required to reduce tension of service conductor.

Number of Services and Meters

218. The Company will install only one set of service conductors (one voltage) to a building or structure. If one customer occupies the building, only one watt-hour meter will be installed. If occupied by several different families or businesses each one will become a customer of the Company, and a meter for his service must be installed.

219. In multiple occupancy buildings each customer's service entrance conductors shall be in a separate raceway or cable, unless the meters for all customers are located at a common point accessible at all times to the Company employees. In this case, that portion of the service entrance between the weather head and the meters is common to all customers. Each customer's main switch or other service equipment must be in his own portion of the building or in a publicly accessible place.

Application for Service

220. The Company will receive application in person or by telephone for original or additional service at any local office. Full information concerning such application will be furnished. A security deposit may be required.
221. Customers or prospective customers should advise the Company of contemplated installations as early as possible in order that details for furnishing service may be worked out and necessary materials obtained. This will prevent delay so that service may be established at the desired time.
222. It is necessary that applications show street numbers, lot and block number or other means of locating the customer's premises and a corresponding identification system be visibly installed at the customer's premises to aid the Company in finding the proper location.

Alterations and Additions

223. When the Company connects a customer's facilities to its supply lines, arrangements are made for meters, transformers and other equipment to match the installation as it is at that time. It is essential that the customer or contractor give notice to the Company of any large additions in load. It is desirable for them to consult with the Company before adding such loads so that the Company's equipment of the proper size will be provided. If the customer wishes to make any alterations in his service or desires the relocation of any Company equipment or facilities at any time following the establishment of his service, the customer must notify the Company, obtain its approval and bear the entire cost of such changes.

Use of Service by Customer

224. To safeguard both the property of the customer and that of the Company, the customer is cautioned against over sizing either the main fuses or those of branch circuits by installing fuses or circuit breakers larger than approved by the National

Electrical Code.

225. The customer's wiring and equipment are to be maintained by him in the condition required by the insurance and governmental authorities having jurisdiction. The customer will use the equipment and service in such a manner as not to disturb the Company's service to other customers.
226. For reliable, quality service it is necessary that the wiring on all single phase three wire installations be balanced so that the current will be, as nearly as possible, the same in each load wire with the neutral wire carrying a minimum of current. In installations, especially of a commercial type, where the single phase load is the majority factor it is recommended that careful consideration be given to the use of four wire WYE service, if available. Complete details of the advantages of this type of service where applicable, can be obtained from the Company.
227. It is also necessary, for good service, that the customer must take action to properly balance the load on each phase of all three-phase circuits.

Interruption of Service and Liability

228. The Company will endeavor to furnish continuous service but does not guarantee uninterrupted service; is not liable for any damage which the customer may sustain by reason of the loss of energy, or the loss of one or more phases; nor is the Company liable for any damage due to reversal of phases; unless such reversal occurs as a result of Company work; nor is the Company liable for damage that may be incurred by the use of any service wiring, connections, instruments, services or electrical appliances installed by or for the customer; nor is the Company liable for damages that may be incurred due to the presence of the Company's property on the customer's premises. If the customer requires three-phase service, the installation and maintenance of adequate relays and circuit breakers to protect against single-phase conditions, and phase reversal is advisable and the installation and maintenance is the responsibility of the customer. Further, the Company strongly recommends that ALL MOTORS (INCLUDING SINGLE PHASE) BE PROVIDED OVERLOAD PROTECTIVE DEVICES.

Grounding

229. Ground wires and ground rods installed in accordance with the requirements and specifications of the latest approved edition of the National Electrical Code, or in

accordance with the requirements of local authorities or other inspection agencies having jurisdiction are minimum requirements for service entrance installations.

230. Minimum code grounding requirements are based on national average conditions. Our service area experiences a higher than average level of lightning activity and the customer's equipment is subject to more probability of damage from this cause. Although there is no known positive protection from the higher magnitude lightning surges, the best grounding possible, within economic reason, as close to the equipment as possible is the best protection.
231. An approved ground system and ground electrode system as specified in the latest approved edition of the National Electrical Code shall be supplemented by requirements of the Company and other authorities having jurisdiction. The Company requires the customer to install a 5/8" by eight foot solid ground rod or 3/4" by eight foot galvanized iron pipe as a grounding electrode with a grounding electrode conductor from the ground rod to the ground connection in the meter base. The Company requires that the ground electrode system be electrically bonded to other systems used as grounding electrode systems such as house water system, underground piping system well casing, etc. The Company only accepts copper grounding conductors in the meter bases. The Company suggests that contractors advise customers of these requirements in order that they know their importance.
232. The Company cannot allow the installation of foreign grounding conductors within its pad-mounted switchgear and transformers or the attachment of foreign grounding conductors to its grounds. Exception: bonding of above ground metallic supply and communication enclosures that are separated by a distance of six feet or less from our pad-mounted switchgear and transformers is acceptable.

Final Connections

233. THE COMPANY WILL MAKE ALL FINAL CONNECTIONS BETWEEN THE COMPANY'S MAINS AND THE CUSTOMER'S WIRING AND IT WILL NOT PERMIT UNAUTHORIZED CONNECTIONS.

Inspections

234. The wiring and appliances of the customer should be installed and maintained in accordance with and should conform to the requirements of the latest approved editions of the National Electrical Code and to such state, county and municipal

inspection requirements as may be in force at the time installation is made.

235. Where law requires inspection, the customer must have the wiring inspected and approved by an authorized electrical inspector and have the installation released for connection before the Company can make connection to its system. The Company is prohibited by law from making service connections until a favorable release is received.
236. In those areas served by the Company where an authorized electrical inspector's final report is not mandatory by law, the Company shall have the right, but shall not be obligated, to inspect any installation on the customer's premises before electrical energy is supplied or at any later time, and reserves the right to reject any wiring or appliance not installed in accordance with the Company's standard requirements. Such inspection, or failure to inspect, or to reject, shall not render the Company liable or responsible for any loss or damage resulting from defects in the installation, wiring, or appliances or from violation of the Company's rules, or from accidents which may occur upon the premises of consumer directly or indirectly as the result of the connection of the electrical source. In case of disagreement, the Company reserves the right to have such an inspection made at its expense by a certified electrical inspector and favorable report rendered by him before electrical service will be established.
237. CUSTOMERS SHOULD BEAR IN MIND THAT THE REQUIREMENTS OF THE NATIONAL ELECTRICAL CODE ARE MINIMUM REQUIREMENTS AND SHOULD NOT OVERLOOK THE PROBABILITY THAT IN THE FUTURE THEY WILL HAVE NEW OR ADDITIONAL EQUIPMENT FOR WHICH MINIMUM WIRING WILL BE INADEQUATE (SEE SECTION 6).

Meter Tampering, Seals and Fraudulent Use

238. After the customer has applied for and/or received service from the electrical utility, he shall make every reasonable effort to prevent tampering with the meter and service drop/service lateral serving his premises. A customer shall notify the Company as soon as possible, of any tampering with, damage to, or removal of any equipment.

TAMPERING WITH METERS OR WITH CONDUCTORS CARRYING UNMETERED CURRENT AND UNAUTHORIZED BREAKING OF UTILITY'S SEALS IS PROHIBITED BY LAW AND WILL NOT BE TOLERATED BY THE COMPANY. THE COMPANY MAY DISCONTINUE SERVICE IF THE METER,

CONDUCTORS OR SEALS HAVE BEEN TAMPERED WITH.

239. Any form of meter tampering and/or fraudulent use may be cause to take one or more of the following actions against the customer:

- Terminate the service.
- Charge the customer for unauthorized energy use.
- Charge the customer for damage to Company equipment.
- Prosecute the customer for violation of state law.

240. SOUTH CAROLINA STATE LAW PROVIDES FOR FINES OF UP TO \$10,000 AND/OR IMPRISONMENT UP TO 10 YEARS FOR METERING TAMPERING OR FRAUDULENT USE OF ELECTRICITY.

Section 3: Overhead Service

General

301. An "Overhead Service" is the complete wiring system from the Company's overhead distribution lines to a building including the customer's service entrance wiring and service equipment. The "service conductor" is the overhead conductors from the Company's distribution lines to the building. The "service entrance conductors" are those conductors installed by and at the expense of the customer between the point of attachment of the "service conductors" to the customer's building and the customer's "service equipment" within or on the building.
302. If, in order to comply with requirements of governmental agencies, it becomes necessary for the Company to make changes in the location of its equipment or to change the character of its service, the customer will, at his expense, make such changes in his wiring, service entrance and utilization equipment as are necessary.

Service Conductors – Attachment Point

303. In order to avoid errors, the customer, architect, or contractor must obtain from the Company the location of the point of attachment on the building of the Company's service conductors. Upon inquiry by the customer, the Company will as far as practicable designate a location for service conductors and their point of attachment to the building that is mutually acceptable. The Company will assume no responsibility to change the location of its service conductor attachments if an improper location is chosen without consultation with the Company or if the mutually accepted location is not utilized. If in the opinion of the Company there is a reasonable appropriate location on a building where the Company's service conductors can be attached by running them from an existing pole, and the customer wants another pole set for his convenience or desire, the customer shall pay the cost thereof and such extra facilities will become the property of the Company.

Service Entrance General

304. The point of attachment should not be more than 30 feet above ground unless a greater height is required to obtain the proper clearance. WHERE THE DESIGN OF THE BUILDING WILL NOT PERMIT THE ABOVE-MENTIONED CLEARANCES, SOME TYPE OF SERVICE STRUCTURE SATISFACTORY TO THE COMPANY MUST BE PROVIDED BY THE CUSTOMER TO OBTAIN

THESE CLEARANCES. Pictures showing suggested methods for providing required clearances are included in the appendix. In all cases the above clearances must be in compliance with the latest approved National Electrical Safety Code and municipality restrictions. The contractor shall obtain clearance requirements from the Company.

305. The point selected for the attachment of the overhead service conductors shall be located so that it is not necessary to install more than one set of wire attachments on the customer's building. The attachment point shall not be closer than three feet to the side of any window, awning, porch, fire escape or other parts of the building, which are readily accessible to persons. The point of the attachment should not be located above uncovered porches, platforms, oil tanks or other elevated projections unless a clearance of 10 feet above such projections is maintained (for voltages of not more than 150 volts to ground). In all cases, clearances shall comply with latest approved edition of the National Electrical Safety Code.
306. Safe and adequate anchoring structures for the Company's service conductors are required of the customer, and in no case will the Company be responsible for the condition of any customer's building or structure to which service wires are attached or have been attached. Where mast services are required for attaching service conductors, rigid galvanized iron conduit must be used and fastened with a minimum of two - two hole straps attached with toggle bolts. Couplings are not allowed above the top strap. (Other types of conduit are not acceptable).
307. The Company will furnish and the customer will install service drop attachment fittings on all buildings requiring overhead service. The point of attachment shall be suitable to hold the strain of the attachment secondary conductors. Where anchor bolts are required they shall be 5/8 inch galvanized. These bolts must be installed in a structural member of the building. A washer not less than 1/8 inch thick and two inches square must be installed under the head of each bolt. The threaded portions of the bolts are to project at least two inches beyond the outer surface of the building wall. Secondary conductors to be a maximum 125' in length. Service attachment points shall be able to support 1,000 pounds of tension.

Service Entrance Conductors

308. The service entrance conductors may consist of continuous lengths of multi-conductor cable approved for the purpose or of individual conductors installed in

an approved raceway. It is permissible to use an un-insulated neutral wire in conduit provided that the un-insulated conductor and raceway metals are compatible, or service entrance cable provided with an un-insulated neutral wire in conduit, or service entrance cable provided with an un-insulated neutral conductor. The use of service entrance cable is prohibited in certain areas by local authorities and contractors should determine prior to making such installations, if service entrance cable is approved for use. SERVICE ENTRANCE CABLE (IF APPROVED FOR USE) AND CONDUITS SHALL NOT BE CONCEALED BETWEEN THE WEATHERHEAD AND THE METER.

309. In order to prevent moisture from entering the raceway of service entrance conductors or service cables, it is advisable to terminate them on an outside building wall at a point approximately six inches above the point of attachment of the highest service conductor so that the individual service entrance conductors will extend downward to the points where connections are made to the service conductors. These features make advisable the use of an approved fitting (weather head) at the outer end of the service conductors, which permits the conductors to extend downward only. When it is impossible to locate the termination of service entrance conductors or service cable above the point of attachments of the service conductors, a drip loop must be formed with the service entrance conductors as they are connected to the service conductors. For complete details see latest approved edition of National Electrical Code.
310. The location of the service entrance weather head shall be close enough to the point of attachment of the overhead service conductors so that wires extending out of the weather head can be connected to the overhead service conductors without splicing. The side clearances shall be the same as those required for the overhead service conductors.
311. Each conductor of the service entrance shall extend no less than two feet beyond the weather head for wires smaller than 1/0 and not less than three feet for wires of number 1/0 and larger to provide sufficient length for connection to the overhead service conductors. Where drip loops are required these conductors shall be further extended sufficiently to permit the bottom of the loops to project at least eight inches below the weather head.
312. To protect the service entrance conductors and prevent the entrance of moisture, all conduit and fittings used in the service entrance raceway are to be made rain-tight. Also, rain-tight fittings shall be used on service entrance cable at all points of connection between cable and meter sockets or other outdoor service

equipment.

313. Where conduit is used, fittings with removable covers in the service conduit ahead of the meter are prohibited except in very special cases and then only with prior approval of the Company. If they are permitted, they cannot be concealed and approved lockable or sealable cover types must be used.
314. In general, where no accessible common meter location is available for buildings, such as duplex houses, apartment buildings, etc., separate sets of service entrance conductors must be brought out to a common point on the building wall to be connected to a single service drop.
315. Wires carrying metered energy are not to be located in the same raceway with wires carrying un-metered energy.
316. All service entrance conductors must be of sufficient size to conform to the rated ampacity of the service entrance equipment and also of sufficient size to provide for reasonable future load increases.
317. Refer to the latest edition of the NEC to determine the correct service entrance size and allowable number of conductors in conduit. The Company strongly recommends that service entrance conductors smaller than #2 copper or #1 aluminum not be used. Further, the Company recommends that all single-phase service be a minimum of three wire 100 amperes.
318. It is required that the neutral conductor of the service entrance wiring be plainly identified. Bare or substantially white insulated wires are sufficient identification. It is further required that on a 4 wire three phase Delta service the conductor having the highest voltage to ground (high-leg) be connected to the center position (B phase) of the customer's main line switch and to the line and load terminals on the right hand side of the meter socket (Note: Prior to 1975 the NEC did not specify the location of the "high-leg"; therefore, the customer should take all necessary precautions to properly identify the "high-leg by marking its location orange"). This conductor is to be identified at all connection points including weather head, meter socket, and main switch.

Section 4: Underground Service

General

401. The Company's standard method of service is overhead. Underground service is available to individual customers as well as developments provided certain required conditions are satisfied. **WHENEVER UNDERGROUND SERVICE IS DESIRED, THE CUSTOMER MUST CONTACT THE COMPANY REPRESENTATIVE AS SOON AS POSSIBLE.**

For commercial underground services, see the Underground Commercial Electric Service booklet.

For residential underground services in underground subdivisions, see the Underground Residential Electrical Service for New Developments booklet.

402. For all underground services the Company, as far as practicable, will designate a location for the service point to the building or in some cases a service point remote from the building to which the customer must bring his service conductors. The Company will assume no responsibility for changing the location of the service conductor if an improper location is chosen without consultation with the Company or if the previously designated location is not utilized.
403. If, in order to comply with requirements of governmental agencies, it becomes necessary for the Company to make changes in the location of its equipment or to change the character of its service, the customer will, at his expense, make such changes in his wiring, service entrance and utilization equipment as are necessary.

Service Entrance Conductors

404. In general where no accessible common meter location is available for buildings such as duplex houses, apartment buildings, etc. separate sets of service entrance conductors must be brought out to a common point on the building wall to be connected to a single service lateral.
405. Wires carrying metered energy are not to be located in the same raceway with wires carrying un-metered energy.
406. All service entrance conductors must be of sufficient size to conform to the rated ampacity of the service entrance equipment and also of sufficient size to provide

for reasonable future load increases.

407. It is required that the neutral conductor of the service entrance wires be plainly identified. Bare or substantially white insulated wires are sufficient identification.

Underground Service in Overhead Districts

408. Company supplies standard overhead service to the customer. When underground service is desired, customers should contact the local Company office and obtain information as to what type of service is available or can be supplied.

For commercial underground services, see the Underground Commercial Electric Service booklet.

For residential underground services in underground subdivisions, see the Underground Residential Electrical Service for New Developments booklet.

409. The following rules apply for residential underground services fed from overhead supply hereafter referred to as “hybrid services”.
- a. Customer should contact local Company office and obtain information as to whether a new hybrid service or conversion from overhead service to hybrid service is available. This is determined on a case-by-case basis due to differing field conditions.
 - b. If Company determines location is suitable for a hybrid service, the customer is responsible for all costs associated with installation of or conversion to a hybrid service. This would include installing the below grade conduit, the riser conduit on the pole, and the meter socket or conversion of the meter socket to accept underground service.
 - c. For new hybrid services - The customer will pay in advance the difference between the estimated cost of the hybrid and the estimated cost of a new overhead service of the same current carrying capacity.
 - d. For conversion from overhead to hybrid - The customer will pay for the cost of removing the overhead service and all costs associated with the installation of the hybrid service.

410. The customer must have further special permission to install a meter on the Company's pole and if at any time it becomes necessary for the Company to change the location of a pole upon which an underground service terminates, the necessary changes in the service will be made at the customer's expense.
411. Recommendations for the installation of underground services are shown on drawings in the appendix.

Underground Services from Underground Distribution

412. As previously explained, the details of service from underground distribution are more fully explained in the Company's Residential and Commercial Underground Booklets. These booklets specifically and individually provide details for single-family dwellings, apartments, condominiums, mobile homes, and commercial customers.

Underground Services in Underground Network Area

413. In certain prescribed districts or streets where the Company maintains an underground network system, underground services will be installed. Metering could be self-contained or instrument rated, see sections 527, 528, 541, and 542 to determine type metering. Note: Please confirm the type of metering equipment required with Company Meter Department for each job. Technological advances result in constant changes for metering equipment. Customers should request short circuit current values from the Company prior to proceeding with plans for underground service.
414. Locating metering equipment in underground network areas is handled on a case-by-case basis due to the unique nature of these situations. Please contact Company Meter Department to determine proper location and application of metering equipment.
415. In some cases it is impossible for the Company to determine in advance the exact location at which service entrance conductors will enter a building on account of possible interference from obstacles in the street. Because of this uncertainty, the installation of the customer's service entrance equipment should not be made until after the Company has completed the layout of the service entrance raceway into the building, or until definite arrangements have been made with the Company.

416. The use of properly rated standard service equipment is required for all underground service installations. Due to the difficulty involved in later increasing the size of underground installations to provide for increased loads, it is especially important that they be made large enough for the expected future increase in load. This is particularly advisable with respect to underground raceways. Service entrance equipment shall not be installed in any location that is likely to become obstructed or inaccessible, and should be installed in location, which will not be used for any other purposes. Conductors shall be in accordance with code requirements for this type of application. Meter installations and the preparation for them shall be in accordance with the type of service required as shown in Section 5 of this manual.

Section 5: Meter Installations

General Requirements

501. Many types of metering installations are required to adequately register the sale of electricity to customers. Factors such as voltage, load, rates, phase connectors, and location are involved. THE COMPANY MUST, THEREFORE, RESERVE FOR ITSELF THE ENTIRE DECISION AS TO HOW, WHERE, AND WHAT TYPE OF EQUIPMENT IS TO BE INSTALLED. The Company will, as far as practicable, cooperate with contractors and customers as to the location and feasibility of installations in accordance with the desires of the customer.
502. Some types of installations are so familiar to contractors that customers may depend on them to make installations which meet Company requirements without consultation with the Company, but if this is done it in no way obligates the Company to relinquish any of the decisions reserved for itself in these specifications.
503. In general, all meters and metering equipment at secondary voltages must be installed on the source side of customer's service entrance and/or service entrance equipment, i.e., main disconnect, unless otherwise instructed by the Company or the Company gives permission. On all new or existing installations that are to be rearranged in any way that affects the customer's service entrance and/or service entrance equipment, i.e., meter disconnect, standard meter socket and/or instrument transformer cabinet shall be installed.
504. In Section 9 there are drawings and pictures that may be used as a guide for the installation of typical jobs, after proper consultation with, and approval of the Company. All of the rules in the text of this section, however, are to be considered as supplementing them and considered a part thereof.
505. THE COMPANY REQUESTS THAT ELECTRICIANS AND ELECTRICAL CONTRACTORS PLACE A STICKER WITH THEIR NAMES, ADDRESSES, AND TELEPHONE NUMBERS ON EACH INSTALLATION, PREFERABLY ON THE SERVICE EQUIPMENT CABINET. THIS WILL FACILITATE COOPERATION BETWEEN THE COMPANY, CUSTOMER AND CONTRACTOR.
506. A guide listing the most common items involved in metering is shown in the following table. This table also shows who is responsible for furnishing, installing and maintaining the equipment. The Company reserves the right to determine

appropriate metering method for each installation. Contact the Company to determine metering method before ordering any equipment. Contact Company Meter Department for any non- standard applications – aid to construction may be required.

Metering Equipment Guide

SERVICE TYPE	CUSTOMER MAIN	TX KVA	FEED	MAXIMUM WIRE SIZE	METER TYPE	METER SOCKET	SOCKET BY
120/208V 4W WYE	0 - 200 amps	-	OH or UG	-	Socket, Form 16S	7 jaw socket	Customer
120/208V 4W WYE	201 - 600 amps	-	OH	-	Bolt-In, Form 9K	K-7T bolt-in	Customer
120/208V 4W WYE	201 - 600 amps	-	UG	-	Bolt-In, Form 9K	K-7SW bolt-in	Customer
120/208V 4W WYE	601+ amps	≤ 150 KVA	OH	2 ea. 600MCM, or 3 ea. 350MCM	Bolt-In, Form 9K	K-7T bolt-in	Company
120/208V 4W WYE	601+ amps	≤ 150 KVA	UG	2 ea. 600MCM, or 3 ea. 350MCM	Bolt-In, Form 9K	K-7SW bolt-in	Company
120/208V 4W WYE	601+ amps	> 150 KVA	OH or UG	-	CT Meter, Form 9S	A-Base	Company
120/208V V-phase (Network)	0 - 200 amps	-	OH or UG	-	Form 12S	5 jaw socket	Customer
120/208V V-phase (Network)	201 - 600 amps	-	OH or UG	-	Bolt-In, Form 12K	K-5T bolt-in	Customer
120/208V V-phase (Network)	601+ amps	≤ 100 KVA	OH or UG	2 ea. 600MCM, or 3 ea. 350MCM	Bolt-In, Form 12K	K-5T bolt-in	Company
120/208V V-phase (Network)	601+ amps	> 100 KVA	OH or UG	-	CT Meter, Form 5S	A-Base	Company
120/240V 3W 1PH	0 - 200 amps	-	OH or UG	-	Form 2S	4 jaw socket	Customer
120/240V 3W 1PH	201 - 600 amps	-	OH or UG	-	Form 2K	K-4UT bolt-in	Customer
120/240V 3W 1PH	601+ amps	≤ 100 KVA	OH or UG	2 ea. 500MCM, or 4 ea. 350MCM	Form 2K	K-4UT bolt-in	Company
120/240V 3W 1PH	601+ amps	> 100 KVA	OH or UG	-	CT Meter, Form 5S	A-Base	Company
120/240V 4W Delta	0 - 200 amps	-	OH or UG	-	Form 16S	7 jaw socket	Customer
120/240V 4W Delta	201 - 600 amps	-	OH	-	Bolt-In, Form 9K	K-7T bolt-in	Customer
120/240V 4W Delta	201 - 600 amps	-	UG	-	Bolt-In, Form 9K	K-7SW bolt-in	Customer
120/240V 4W Delta	601+ amps	≤ 150 KVA	OH	2 ea. 600MCM, or 3 ea. 350MCM	Bolt-In, Form 9K	K-7T bolt-in	Company
120/240V 4W Delta	601+ amps	≤ 150 KVA	UG	2 ea. 600MCM, or 3 ea. 350MCM	Bolt-In, Form 9K	K-7SW bolt-in	Company
120/240V 4W Delta	601+ amps	> 150 KVA	OH or UG	-	CT Meter, Form 9S	A-Base	Company
277/480V 4W WYE	0 - 225 amps	≤ 150 KVA	OH or UG	1 ea. 350MCM	Form 16S	Integrated disconnect	Company
277/480V 4W WYE	225+ amps	> 150 KVA	OH or UG	-	CT Meter, Form 9S	A-Base	Company

Metering Selection Guide.xls (2013)

Meter Location General

507. The preferred location for meters is outdoors. This is a definite requirement for all residences and small commercial buildings. (See paragraph 522 on Grouped Installations). When any customer, falling in the above category, who has his meter installation indoors, makes any change involving his service entrance equipment or meter installation, he must make the necessary revision in his wiring to provide for the meter to be moved outdoors.
508. Meters for large commercial customers or others in congested areas may be indoors or outdoors as specified by the Company.
509. If, after the Company's portion of the work involved in a meter installation is completed, the customer desires the meter to be relocated for his convenience and the Company approves the relocation, the customer will bear all costs involved.

Meters Located Outdoors

510. Meters installed outdoors shall be located in places readily accessible to authorized Company representatives for installation, maintenance, reading, or removal. For multiple occupancy buildings with multiple meters, meter sockets must be plainly and permanently marked to indicate the area served (see paragraph 524 for marking requirements).
511. Meters shall not have any type structure, plant or other encumbrance within a three-foot radius of the meter face. Meters shall not be installed where the Company's meter readers or service people may inadvertently damage flower beds or shrubbery or where it will be necessary for them to climb over fences or other obstructions to read or service the meters, or in locations where they may be accidentally damaged such as on buildings where they will extend unguarded into stairways, alleys, walkways, or driveways. They shall not be installed on walls or in areas subject to severe vibration, nor on porches, carports, breezeways, or any location likely to be enclosed in the future. They shall not be installed over or under fuel oil drums, nor close enough to such drums as to prohibit free access to the meters. They shall not be installed under roof valleys of buildings with eaves less than 12 inches in width. Meters must be installed on the building where there is sufficient structural integrity to provide a mounting for the metering equipment. The customer may be required to provide additional structural integrity if deemed necessary by the Company.

Meters Located Indoors

512. The Company will not install meters indoors except in unusual circumstances. In the event no outdoor location is feasible, the details for the location of the indoor meters must be pre-approved by the Company.
513. Each meter located in an individual area in multiple occupancy buildings must be served by a separate set of conductors in a separate raceway from the point on the outside of the building where the service drop is attached. Meters located in a common area serving two or more occupants of the same building may be served by a single set of service entrance conductors.
514. Meters should preferably be located on the first floor of multi-story buildings, but may be located in basements or other floors provided all other requirements of these rules and the rules for mounting and group installations are met. Meters shall be located in basements only when the ceilings are normal room height and it is provided with a regular stairway, which is opened or closed with a standard doorway.
515. Meters shall not have any type structure, plant or other encumbrance within a three-foot radius of the meter face. Meters must be located in areas where they will be readily accessible to Company personnel for installation, maintenance, reading, testing, inspection or removal.
516. Meters must not be located in areas enclosed by trap doors or panels, or on lattices or in coal or wood bins, in sheds, attics, bedrooms, bathrooms, toilet rooms, restaurant kitchens, stairways, ventilating or elevator shafts. They must not be located in areas where there is excessive vibration or dampness. They shall not be installed in furnace or boiler rooms except by special permission of the Company. Meters must not be installed near belts or other moving machinery that would endanger the safety of those doing work near or on the meter. Meters should not be installed in any place where unnecessary inconvenience will be caused to either the customer or the Company in the performance of its regular duties on customer's premises.
517. Rooms allocated for use of meters should not be used for any other purpose. At least three feet of clear space must be maintained in front of meter installations

Mounting of Meters

- 518. Outdoor meters shall be mounted so that the center of the meter shall be not more than 72 inches and not less than 54 inches (42 inches for ganged) above finished grade level. Ganged meters installed in meter rooms shall be mounted so that the center of the meter shall be not more than 72 inches and not less than 42 inches above floor level.
- 519. It is necessary that the socket be carefully and rigidly mounted so that the plane of the front of the socket will be vertical and so that the meters when mounted on the sockets will be in a true vertical position.
- 520. For fastening equipment and fittings to buildings with wood outside finish, use only screws made of non-corrosive material of adequate strength. For brick, tile or other types of masonry buildings, use only expansion shields, lead anchors or inserts equipped with galvanized steel machine screws.
- 521. Some typical layouts are included in Section 9 of this booklet, but the company should always be consulted for details on any particular job.

Grouped Meters

- 522. Grouped installations at the Customer's option may be made by using "pre-bussed" multi-position units in which the service entrance conductors are connected in the wiring compartment (see appendix). Grouped installations shall be "ringless" in design. In selecting the appropriate method, the requirements of the local authority enforcing code requirements must be considered.
- 523. Grouped installations of meters are special situations generally requiring special methods and equipment. Prior approval with the Company is required before any layouts are made or equipment is specified for job.
- 524. It is required that each meter socket in grouped installations be plainly and permanently marked (on the inside of the meter socket and outside on the meter socket cover) to indicate the area served by each. This rule applies whether meters are installed indoors or outdoors, and whether or not the meters are ganged or individually served from a common service entrance raceway.

An approved method of permanently stenciling the meter sockets with enamel paint for proper identification in all installations is to be adhered to. Markings must

not be made on the meters themselves. Buildings with an appreciable number of apartments or other occupancies are usually numbered or lettered. If so, such designation may be used, if not, some other concise identification should be used such as:

"Corner store"	"Second floor N.E. corner office"
"Middle store"	"Upstairs rear apartment"
"West end store"	"Third floor east center apartment"

This rule also applies to duplex residences or single residences converted into two or more apartments, or a combination of residence and/or stores or offices. When any occupancy is so marked the customer desiring service in such space must provide this information when applying for service.

Meter Wiring

525. There are two basic types of meter wiring regardless of whether the installation is single or three phase. One type is where the customer's service entrance conductors are connected to the meter socket terminals, and is known as a self-contained metering installation. With the other type the customer's service entrance conductors pass through or are connected to instrument transformers, and only the secondary wires from the instrument transformers are connected to the meter socket terminals. This is known as an instrument transformer metering installation. All service conductors (including the neutral) shall be terminated in the self-contained meter socket. All service conductors (including the neutral) shall pass through the instrument transformer cabinet.
526. When Company furnishes and installs residential underground service in approved underground areas, the Company will make connections on the line side of the meter socket and the customer will make connections on the load side of the meter socket.
527. The majority of metering installations are self-contained. Instrument transformer installations are required for larger loads and for 277/480 volt services greater than 200 amps. All 277/480 volt 200 amp services will be self-contained. The Company will supply the 277/480 volt self-contained meter socket with integrated disconnect (the integrated disconnect is for Company use only) and the Customer will install the meter socket for these services. See "Metering Equipment Guide" for the various sizes and types of installations on page 24.

528. All new self-contained installations will be the ringless socket type. The customer will furnish and install the meter socket, which must be UL approved and should be sized to accommodate conductor sizes up to 600 amps. Source conductors shall always be terminated in the top side of the meter, and all service conductors (including the neutral) shall be terminated in the meter socket. When required, 201-600 ampere, 120/240 volt, self contained, single phase and polyphase meters are available (these are used for 120/208 and 120/240 volt services). To accommodate 201-600 ampere self-contained metering, the appropriate size and number of conductors shall be used.
529. Meter sockets are also required for instrument transformer installations. Sockets for instrument transformer meters will be mounted by the customer, except on pole-mounted and pad-mounted transformer installations.
530. All wiring in residential self-contained meter sockets is completed by the customer's electrician except in underground areas where the Company makes the line side connections.
531. Instrument transformer installations in instrument transformer cabinets (approved by the Company) must be coordinated between the customer and the Company to complete the installation. The through (or window) type instrument transformer is furnished by the Company instead of the bar type, in which case the customer and the company must cooperate in the installation to avoid cutting the service entrance conductors. All secondary wiring from the instrument transformer to the meter location (approved by the Company) is furnished and installed by the Company. The customer will furnish and install a one inch EMT or galvanized iron conduit from the transformer cabinet to the meter location. The conduit run installed by the customer shall be as short as possible and not to exceed 50 feet in length. The Company requires that all meters be located outdoors and the Company shall be consulted on all metering installations involving instrument transformers. Meters located at other designated locations and/or indoors are only allowed in unusual circumstances. In the event no outdoor location is feasible, the details for the location of the instrument transformers and metering must be pre-approved by the Company.
532. In self-contained installations, no wiring except the service entrance conductors and grounding conductors may pass through the meter socket. In indoor instrument transformer installations, no wiring may pass through the instrument transformer cabinet except the service entrance and grounding conductors. No wiring may pass through the instrument transformer meter socket except that

installed by the Company. Only Company owned equipment is allowed in the meter socket.

533. All service entrance equipment, including wiring troughs, pedestals, and/or raceways, containing un-metered wires shall be of the sealable type.
534. It is required that the high voltage leg and neutral of four wire delta service entrance conductors be identified in each box, cabinet, switch or trough through which they pass. They shall be identified at the entrance weather head. Neutral or grounding conductors of any system must be readily identifiable. Gray or white wire is sufficient identification for neutral conductor. Bare, green or green with yellow stripe is sufficient for grounding conductor. Orange will be used to identify the "high leg".
535. The line side high voltage leg of a delta system should always be attached to the top right terminal in meter sockets. The load side high voltage leg of a delta system should be connected to the bottom right terminal in meter sockets.
536. In instrument transformer installations where it is not practical to use window type transformers or instrument transformer cabinets, the transformers may be mounted in a bus structure provided they are readily accessible to authorized Company representatives for checking, testing, and replacement. However, before such installation is made, the Company should be consulted regarding the location of the meter and facilities required.

Freestanding Switchboards

537. Where the customer's installation is of the switchboard type, and the Company desires it, meters and metering devices of the switchboard type will be used and mounted on an approved panel furnished by the consumer. This panel or panels will be reserved exclusively for the metering equipment.
538. The Company will supply necessary information to the customer for the fabrication of switchgear in which instrument transformers are to be installed. The Company will furnish the instrument transformers for the customer to install. The Company will install the instrument transformer secondary wiring after all service entrance equipment is installed.
539. Freestanding panels provided for meter installations are to have at least three feet clear space in the back and front from any permanently installed obstruction.

540. All such installations shall be considered special and arrangements made with the Company well in advance of the need.

Additional Notes on Metering Facilities

541. Self-contained installations may be specified on loads not expected to be in excess of 600 ampere, 277 volts or less. If the customer's service entrance equipment and conductors are appreciably larger than the initial load, the self-contained equipment as specified in the table may not apply. In this case, contact the Company for special instructions. Commercial and industrial customers contact the Company for requirements on demand meters. Connection diagrams of self-contained and instrument types of metering installations are shown in Section 9.
542. Service at high voltages, above 480 volts, is subject to special negotiations between the customer and the Company. Because the meter and service installation for such service requires special engineering considerations, it is always essential to consult the Company well in advance of the time such service will be required. This will allow necessary time for the customer's and the Company's design and construction to be properly coordinated and equipment obtained.

Section 6: Service Equipment

Location

601. Customer service equipment locations are to be in accordance with the latest approved edition of the National Electrical Code (local codes and other authorities having jurisdiction) and should always be located in a readily accessible place as close as practicable to the electrical load center and in a place not likely to become obstructed by future alterations or cause inconvenience to the customers when it becomes necessary to operate the equipment or renew fuses.
602. Consideration should be given to the location of branch circuit protection devices on the same floor served by the circuits. The use of such sub-distribution centers fed by suitable feeder circuits will result in short branch circuits and improved service

Interrupting Capacity of Protecting Devices

603. The Company will, upon request, supply necessary information concerning available fault current to enable the customer to determine the required interrupting capacity of protective devices which are to be installed at any definite location on the system. (This is of particular importance in network areas, or where the size of the service is large.) While the Company will endeavor where possible to anticipate system changes which may affect these values, it does not assume responsibility or liability with respect to such protective devices, nor does the Company guarantee their continuing adequacy against increased fault current interrupting requirements resulting from system growth and changes.

Single Phase Service Equipment

604. The protective equipment installed, regardless of type, should be of such capacity as to permit the full utilization of the capacity of the service entrance conductors installed at the time of original installation and vice versa. This will tend to minimize expensive reinstallation of service conductors or equipment as the load increases. Automatic circuit breaker type service equipment is preferable in all cases and its use is strongly recommended. It provides a means by which service may be readily restored immediately and conveniently when interior trouble causes them to operate.
605. Size of service entrance conductors and equipment shall have sufficient ampacity

to carry the load as determined by latest approved edition of the National Electrical Code.

- 606. Service entrance conductors shall be without splice except at the meter enclosure where an approved bolted connection for copper wire and approved compression connection for aluminum is permitted.
- 607. Unless otherwise required by local authority, a main disconnecting means is not required for six circuits or less. If more than six circuits are needed, a main switch must be provided, or the circuits grouped on sub-mains so that the total number of disconnect mains to all circuits shall be six or less and located at the same place

Three Phase Service Equipment

- 608. Although fuse type equipment is acceptable, automatic circuit breakers are preferred for this class of service because of the convenience in immediately restoring service and the automatic interruption of all three phases supplying power to the equipment when the circuit protection operates.
- 609. Three-phase service is usually required for industrial and large commercial customers and requires special design considerations. The Company is available for consultation for such services; however the customer should contact his architect, engineer or electrical contractor as soon as possible.
- 610. Special contractual arrangements for the installation of three-phase service in certain areas may apply and advance permission must be obtained. See Section 8.

Section 7: Transformer Vaults and Underground Primary Services

Vaults General

701. This section is intended to cover only the major considerations of a highly specialized type of service. This type of service is usually confined to serving one large customer of commercial or industrial character and each installation will present individual problems, which will have to be resolved by close coordination between the customer, his representatives and the Company.

Customer service considerations often make it necessary to place transformers as near the load as possible, sometimes in vaults constructed by the customer on his premises. This is particularly true where the load is of considerable magnitude. The Company will furnish the customer general guidelines and requirements for vaults, when requested. Customers, architects and/or contractors will, therefore, please consult the Company in regard to the necessity, location and requirements for such transformer vaults before construction is started. The vault location plans and details must be approved by the Company prior to construction.

702. Transformer vaults shall contain only the supply transformers and associated equipment, and UNDER NO CONDITIONS are any meters or customer's secondary fuses, switches, or other customer's equipment to be installed therein. Secondary devices and meters, however, should be installed as near the transformer vault as practicable.

703. The National Electrical Code provides specific design limitations for transformer vaults in buildings. Always consult appropriate inspection authorities concerned before planning or building transformer vaults. Building regulations are not necessarily uniform.

Underground Primary Services

704. Underground Primary Services are to be considered special in all cases and permission for such installations shall be obtained from the Company in advance.

705. Underground primary service will be provided only when overhead service is not feasible, or when it is mutually advantageous to the Company and customer.

706. All customers desiring to receive energy at primary voltages, who will own their own distribution facilities, or utilize service at primary voltages, and who desire underground service shall furnish, install and maintain such service entrance facilities.

Customers Vault

707. For customers who provide vaults or Company owned transformers that serve no other customers and who receive service at secondary voltages (whether primary metered or not) the Company will:

(1) Where the vault is adjacent to the street property line, furnish, install and maintain the primary service entrance facilities.

(2) Where the vault is installed some distance from the street property line for the customer's convenience or to reduce his secondary wiring costs, the Company will furnish, install and maintain the primary raceway to the property line and the customer shall furnish, install and maintain the primary raceway from the street property line to the vault.

Section 8: Power and Special Equipment Installations

Motors-General

801. The following requirements apply to all motors connected to the DISTRIBUTION SYSTEMS of the Company.
802. The National Electrical Code provides that some motors less than one horsepower and that all motors one horsepower and above be equipped with suitable starting switches having overload protection.
803. Phase reversal, low voltage, high voltage, or loss of one or more phases can damage motors. To protect motors from these conditions, it is recommended that protective relays or devices be used to automatically disconnect motors from the voltage supply. Such devices are installed and owned by the customer and are his responsibility.
804. The use of automatic time-delay circuit breakers for circuit protection in all cases is strongly recommended. Where fuses are used, they should always be of the time-delayed type. The time-delayed will, in many instances, prevent unnecessary shutdowns due to the tripping of an instantaneous type circuit breaker, or blowing of ordinary short time fuses by larger currents resulting from motor starting, temporary overloads or temporary low voltage conditions. These devices are installed and owned by the customer and are his responsibility.
805. The Company reserves the right to specify voltage characteristics and starting limitations of all motors in order to limit voltage fluctuation and disturbances to its customers. The Company further reserves the right to specify whether it shall supply single phase or three phase service to a customer in accordance with service limitations as set forth in the Company's General Terms and Conditions, and as in the following paragraphs.

Small Motors – 20 Horsepower and Below

806. Motors up to and including 1/2 horsepower may be operated at 120 volts or 240 volts but should be single phase, unless the customer already has three phase service or municipality constraints require three-phase service.

807. Motors 3/4 hp to five horsepower must be operated at 240 volts and should be single phase, unless the customer already has three phase service or municipality constraints require three-phase service.
808. Motors above five horsepower must be operated at a minimum voltage level of 208 volts. The Company reserves the right to require these motors to be three-phase.
809. All motors up to and including 20 hp may be started across the line provided such motors do not cause voltage fluctuations and disturbances to other customers.
810. It is intended that the application of single-phase motors permitted above, generally follow the starting current rules recommended by the ANSI Committee. Those rules, however, are written so that they are readily understood by motor manufacturers but not necessarily by the user. The rules given above are written so the user can readily understand them. They do not completely follow the ANSI rules in all respects. Therefore, in any case where the customer or his motor supplier can show proof that a particular motor or motors can be operated without exceeding the limitations of ANSI rules, then the use of such motors will be permitted.
811. The Company does not assume the responsibility for satisfactory operation of 220 to 250 volt three-phase classes of equipment on 120/208-volt WYE services. The Company does not assume responsibility for satisfactory operation of 208 volt WYE three-phase class of equipment used on 240 volt three phase services.

Large Motors – General Above 20 Horsepower

813. The Company is prepared to furnish to its customer's assistance and advice where new loads are to be added to the Company's lines. Before any motors are installed, it is necessary to consult the Company in order to determine the character and adequacy of the available service and the starting KVA limitations. Existing customers who plan to add motors should also check with the Company.
814. Full voltage starting is the simplest and lowest cost method of starting. Other types of starting that reduce the starting KVA are more expensive, but may be required by the Company to prevent disturbances to other customers connected to the distribution system. Also, for his benefit the customer may want to install reduced KVA starting equipment to eliminate mechanical shock to the motor as well as prevent disturbances to his other equipment.

815. The factors which must be considered before starting KVA limitations can be provided to the customer are the capacity of the Company's distribution system, which varies from location to location, the motor characteristics, and the number of times the motor is to be started which may vary on a daily basis.

Motor Starting Requirements Above 20 Horsepower to 100

816. As outlined in paragraph 814, motors may or may not need reduced KVA starting equipment and BEFORE PURCHASING A MOTOR, the customer must:

- (1) Check with the Company to determine KVA starting limitations.
- (2) Consult the motor manufacturer so that the best motor and starter suited for the job is purchased.

817. The following are guidelines that the Company will use in determining the acceptability of large motors.

- (1) Generally motors 25 through 40 horsepower will be required to have reduced KVA starting equipment that will limit inrush current to 65 percent of locked rotor current.
- (2) Generally motors 50 through 100 horsepower will be required to have reduced KVA starting equipment that will limit inrush current to 33 and one-third percent of locked rotor current.
- (3) Motors must reach at least 85 percent synchronous speed before switching to "run" position.

NOTE: Locked rotor current is generally defined as six times full load current.

Motors Above 100 Horsepower

818. Reduced KVA starting equipment is usually required and all cases shall be submitted to the Company for approval prior to purchasing.

NOTES TO MOTOR STARTING REQUIREMENTS

819. There are many different types of starting equipment and it is important that the customer contact the manufacturer so that motor and starter are properly matched,

which will insure minimum installation and operating costs.

Comparison Table #1

To aid in the selection of the type of starting best suited for the limitation involved.

Type of Starter	Starting characteristics in percent of full voltage values			Advantages	Disadvantages
	Voltage at Motor	Line Current	Starting Torque		
Autotransformer	80 65 50	64 42 25	64 42 25	<ol style="list-style-type: none"> 1. Provides highest torque per ampere of line current. 2. Taps on autotransformer permit adjustment of starting voltage. 3. Suitable for long starting periods. 4. Closed transition starting. 5. While starting, motor current is greater than line current. 	<ol style="list-style-type: none"> 1. In lower HP ratings, is most expensive design. 2. Low power factor.
Primary Resistor	70	70	49	<ol style="list-style-type: none"> 1. Smooth acceleration – motor voltage increases, with speed. 2. High power factor during start, requires expensive resistor. 3. Closed transition starting. 4. Less expensive than autotransformer starter in lower HP ratings. 5. Available with as many as 7 accelerating points. 	<ol style="list-style-type: none"> 1. Low torque efficiency. 2. Resistor gives off heat. 3. Starting time in excess of 5 seconds. 4. Starting voltage difficult to adjust to meet varying conditions.
Part Winding	100	65	48	<ol style="list-style-type: none"> 1. Least expensive reduced voltage starter. 2. Closed transition starting. 3. Most dual voltage motors can be started part winding on lower of two voltage. 4. Small size. 	<ol style="list-style-type: none"> 1. Unsuitable for high inertia, long starting loads. 2. Requires special motor design for voltages higher than 230V.
Wye-Delta	100	33-1/3	33-1/3	<ol style="list-style-type: none"> 1. Moderate cost – less than primary resistor or autotransformer. 2. Suitable for high inertia, long acceleration, loads. 3. High torque efficiency. 	<ol style="list-style-type: none"> 1. Requires special motor design. 2. Starting torque is low. 3. Inherently open transition – closed transition available at added cost

Selection Table #2

To aid in the selection of a starter best suited for a particular characteristic.

Characteristic Wanted	Type of Starter to Use (Listed in order of desirability)	Comments
Minimum Line Current	1. Autotransformer. 2. Wye-Delta. 3. Part Winding. 4. Primary Resistor.	Little choice between 1 and 2 or between 3 and 4.
Smooth Acceleration	1. Primary Resistor. 2. Wye-Delta. 3. Autotransformer. 4. Part Winding.	
High Starting Torque	1. Autotransformer. 2. Primary Resistor. 3. Part Winding.	The part winding motor may not be able to fully accelerate the load until the second winding is connected.
Suitability for Long Acceleration	1. Autotransformer. 2. Wye-Delta. 3. Primary Resistor.	For this classification the primary resistor starter must be provided with a resistor suitable for long acceleration duty.
Suitability for Frequent Starting	1. Primary Resistor. 2. Autotransformer.	In general, the part winding motor is unsuited for frequent starting.

820. Starting equipment other than the types listed in Tables 1 and 2 may meet the Company's starting requirements but the customer must establish proof of this before the Company will give its approval. Customers are advised that it is very difficult to establish such proof unless the motor supplier is the same as the driven equipment supplier. Customers who purchase motors from one source and driven equipment from another source quite often encounter difficulties in placing responsibility for any problems that might arise. Therefore, it is again advised that before purchasing a motor the customer should check carefully with the manufacturer to insure that the best motor and starter for the job is purchased and the torque requirements of the load are matched with the motor torque output. Eighty-five percent synchronous speed should be obtained prior to switching from "start" to "run". This will minimize "bump" in current during the transition from "start" to "run" and will lengthen the life of the motor and starting equipment.

821. On many applications, motors will have to be started unloaded in order to meet the starting requirements imposed by the Company. For example: LARGE REFRIGERATION EQUIPMENT must be brought to rated speed unloaded. HAMMER MILLS under no circumstances shall be loaded during starting. Even when unloaded, hammer mills require excessive starting power and should be given extra considerations.

822. WHERE MOTORS MUST BE START LOADED as in the case of direct drives, conveyors, cotton gins, etc., the squirrel cage or increment type motors may not meet the starting requirements shown above. Wound rotor motors and controls (or other special equipment) may be necessary to meet the requirements.
823. THE GUIDES SHOWN HEREIN FOR LARGE MOTORS ARE GENERAL FOR THE AVERAGE COMMERCIAL AREA. SPARSELY SETTLED AREAS, RESIDENTIAL SECTIONS, AND AREAS ADJACENT TO HOSPITALS, COMPUTER CENTERS, RADIO STATIONS, AND OTHER CUSTOMERS WITH CRITICAL VOLTAGE EQUIPMENT, MAY REQUIRE MORE STRINGENT RULES.
824. Industrial customers with their own substations or other customers in concentrated industrial areas may be permitted to waive these rules upon approval by the Company.

Special Equipment

825. The customer should maintain his power factor as near unity as possible. A good power factor could result in a reduction of monthly billing and may permit the reduction of conductor and equipment sizes. Where large capacity motors are to be installed, consideration should be given to the use of synchronous type equipment.
826. The Company will serve no gaseous tube or other types of lighting equipment if the power factor is less than that of present available high power factor equipment. If power factor corrective equipment is made necessary by this specification, it will be provided and maintained by the customer at his own expense. This applies to all new installations and any changes in existing installations.
827. In general, capacitors must be applied more carefully than most types of electrical equipment in order that satisfactory operation and maintenance will result. The customer should confer with the Company before any installations of this type of equipment are made.
828. Some other items of equipment which require special consideration for proper operations are:

Welders and furnaces
X-ray

Hammer Mills
Large Compressors

Radio & TV Broadcasting Stations

Punch Presses

Industrial Heat Treating

Double Throw Switches

Tankless (Instantaneous) Water Heaters

IT IS ABSOLUTELY ESSENTIAL IN ALL CASES THAT THE CUSTOMER CONSULT THE COMPANY CONCERNING THE ELECTRICAL SUPPLY BEFORE MAKING ANY COMMITMENTS FOR PURCHASE OR INSTALLATION OF THE EQUIPMENT LISTED ABOVE.

Section 9: Supplementary Information and Drawings

Standard Voltages and Corresponding Demand Limitations

Standard Voltage	Peak Demand in KVA	
	Minimum	Maximum
120 V, 1 phase 2 wire	None	25
120/240 V, 1 phase, 3 wire	None	50
120/208 V, 3 phase, 4 wire Wye	30	500
120/240 V, 3 phase, 4 wire Delta	30	500
240 V, 3 phase, 3 wire Delta	30	1500
277/480 V, 3 phase, 4 wire Wye	30	2500
480 V, 3 phase, 3 wire Delta	30	1500
600 V, 3 phase, 3 wire Delta	Negotiate	
2,400 V, 3 phase, 3 wire	Negotiate	
2,400/4,160 V, 3 phase, 4 wire Wye	Negotiate	
4,800/8,320 V, 3 phase, 4 wire Wye	Negotiate	
7,200/12,470 V, 3 phase, 4 wire Wye	Negotiate	
13,800 V, 3 phase, 3 wire	Negotiate	
7,970/13,800 V, 3 phase, 4 wire Wye	Negotiate	
14,400/24,900 V, 3 phase, 4 wire Wye	Negotiate	
34,500 V, 3 phase, 3 wire	Negotiate	
46,000 V, 3 phase, 3 wire	Negotiate	
115,000 V, 3 phase, 3 wire	Negotiate	
230,000 V, 3 phase, 3 wire	Negotiate	

Standard Service Characteristics

The following Service Characteristics are generally standard. The Characteristics of Service that are available shall be obtained from the Company before any wiring is installed or equipment purchased. In cases of multiple occupancy installations, the combined load may be such that the Characteristics of the Service required will be different from that which the individual customer's loads might indicate. In such cases the Company reserves the right to determine the type of service, which will be supplied. (Contact your local office or Customer Service Engineering if you need assistance).

A. 120 volts, single phase, two wire

For highway signs, travel trailers, traffic controllers, CATV amplifiers or other small power loads. The service from the Company's facilities up to, and including, the meter shall be a 120/240 volt, single phase, three wire circuit. Company approval must always be obtained in advance.

B. 120/240 volts, single phase, three wire

For general lighting and/or heating and cooking, and small power loads with individual motors generally not over 5 hp. Where the total load exceeds 50 KVA, the Company may, at its option, require the customer to arrange the wiring for three phase service.

C. 120/208 volts, single phase, three wire (from four-wire system)

For general lighting, heating, cooking and small power loads with motors generally not over 5 hp. Where the total load exceeds 50 KVA, the Company may, at its option, require the customer to arrange the wiring for three-phase four wire service.

D. 120/208 volts, three phase, four wire, wye

For large lighting loads, or combination lighting, heating/cooling and power. Single phase load shall be balanced between phases.

E. 120/240 volts, three phase, four wire, delta

For combination 120/240 volts, three wire, single phase and 240 volts, three-phase service, where the load of either class substantially exceeds that to the other.

F. 277/480 volts, three phase, four wire, wye

For power and general service installations having demands of not less than 30 KVA

G. 480 volts, three phase, three wire

Normally, for power installations having demands of not less than 30 KVA.

H. Service voltages higher than 480 volts are available only by negotiation with the Company. The size and type of customer's load must warrant such an installation.

I. The Company's standard method of providing three phase service is four wire wye. The customer must take the neutral to their service equipment. The Company will not make provisions in its equipment to accommodate a customer's impedance grounded system. Any such equipment will have to be installed on the customer's side of the installation

Drawing Table of Contents

<u>Drawing #</u>	<u>Title</u>
06.01-01	Secondary and Service Construction
06.01-02	Service Details
06.03-01A.....	Mobile Home Overhead Service Notes
06.03-01B.....	Mobile Home Overhead Service Pole
06.03-02A.....	Temporary Overhead Service Notes
06.03-02B.....	Temporary Overhead Service Pole
06.03-03A.....	Residential Overhead Service Notes
06.03-03B.....	Residential Overhead Service (Mast)
06.03-03C	Residential Overhead Service (House Knob)
06.04-01A.....	Mobile Home Underground Service Notes
06.04-01B.....	Mobile Home Underground Service Pedestal
06.04-02A.....	Temporary Underground Service Notes
06.04-02B.....	Temporary Underground Service Pole / Pedestal
06.04-03A.....	Hybrid Service
06.04-03B.....	Residential Hybrid Service - OH to UG Conversion
06.04-03C	Underground Service
06.04-05	Communication Underground Service
19.01-01	Meter Sockets
19.01-03	Meter Clearance Requirements
19.01-04	Meter Socket Mounting Configurations
19.01-05	Modular (Ganged) Meter Assembly
19.02-01	Single-Phase 120V 2W Meter
19.02-02A.....	Single-Phase 120/240V 3W Meter (200 Amps)
19.02-02B.....	Single-Phase 120/240V 3W Meter (201 - 600 Amps)
19.02-03	Single-Phase 240/480V 3W Meter (200 Amps)
19.02-04A.....	Single-Phase 120/208V Network 3W Wye Meter (200 Amps)
19.02-04B.....	Single-Phase 120/208V Network 3W Wye Meter (201 - 600 Amps)
19.03-01A.....	Three-Phase 120/208V 4W Wye (200 Amps)
19.03-01B.....	Three-Phase 120/208V 4W Wye (201 - 600 Amps)
19.03-01C.....	Three-Phase 120/208V 4W Wye (201 - 600 Amps)
19.03-02A.....	Three-Phase 120/240V 4W Delta (200 Amps)
19.03-02B.....	Three-Phase 120/240V 4W Delta (201 - 600 Amps)
19.03-02C.....	Three-Phase 120/240V 4W Delta (201 - 600 Amps)
19.03-03A.....	Three-Phase 277/480V 4W Wye (200 Amps)
19.03-03B.....	Three-Phase 277/480V 4W Wye (200 Amps)
19.04-01	CT Metering Enclosure
19.04-02	CT Metering - Overhead Mast

19.04-03 CT Metering - Pole Mount
19.04-04 CT Metering - Pad Mount Transformer
19.04-05 CT Metering - CT Cabinet
19.04-14A..... Customer Pulses from kWh Meter
19.04-14B..... Customer Pulses Wiring Detail
19.04-14C..... Pulse Terminal Enclosure Mounting Options
19.05-01 Overhead Primary Metering
19.06-01 Customer Generation Metering Configurations
19.06-02 Offset / Sell Wiring Diagram
19.06-03 Buy All / Sell All Wiring Diagram

SECONDARY AND SERVICE CONSTRUCTION

BY JAL

DATE 03-18-19

REV. 2

06.01-01

REV. 2 (03/18/19) - REMOVED SCE&G FROM NOTE 11

NOTES:

1. THE NEUTRAL SHALL BE COMMON TO BOTH PRIMARY AND SECONDARY CIRCUITS ON WYE SYSTEMS AND THE NEUTRAL SHALL BE MULTI-GROUNDED (SEE SECTION 8 FOR ADDITIONAL INFORMATION).
2. THE NEUTRAL CONDUCTOR SHALL **ALWAYS** BE IN THE TOP POSITION ON ALL OPEN WIRE SECONDARY CIRCUITS.
3. SIZING OF SECONDARY AND SERVICE CONDUCTORS WILL DEPEND ON THE AMOUNT OF LOAD, THE TYPE OF LOAD (SUCH AS MOTORS, ETC.) AND THE VOLTAGE DROP. THE REQUIRED SIZE SHALL BE SPECIFIED BY THE DESIGNER AND IDENTIFIED ON ALL WORK ORDERS.
4. WHEN USED WITH A 477 AAC (SAC) NEUTRAL, THE PULLEY BRACKET WILL NOT ACCOMMODATE SERVICE PAYOFFS. AS SUCH, A SECOND PULLEY BRACKET SHALL BE INSTALLED UNDERNEATH THE NEUTRAL PULLEY BRACKET.
5. STREETLIGHT CIRCUITS ARE CONSIDERED AS SECONDARY.
6. SEE DRAWING 01.03-06 FOR CLEARANCE FROM SWIMMING POOLS.
7. SEE DRAWING 03.01-03 FOR OVERHEAD SECONDARY/SERVICE CONDUCTOR AMPACITIES.
8. SEE DRAWING 14.02-01 FOR UNDERGROUND SECONDARY/SERVICE CONDUCTOR AMPACITIES.
9. SEE DRAWINGS 15.01-04, 15.01-05A AND 15.01-05B FOR PAD MOUNT TRANSFORMER AND CABLE IDENTIFICATION METHODS.
10. SEE DRAWING 06.01-02 FOR SERVICE DETAILS.
11. SEE THE CONTRIBUTIONS IN AID OF CONSTRUCTION (CIAC) MANUAL FOR ADDITIONAL DETAILS.
12. SEE SECTION 19 FOR METER SOCKET AND METERING DETAILS.
13. SEE THE TABLE BELOW FOR MAXIMUM UNGUYED MULTIPLEX SPAN LENGTH.

LIMIT FOR ALUMINUM MULTIPLEX WIRES NOT REQUIRING GUYING	
WIRE SIZE	SPAN LENGTH
#4 DUPLEX	150'
#2 TRIPLEX	150'
1/0 TRIPLEX	125'
4/0 TRIPLEX	75'
1/0 QUADRUPLEX	100'
4/0 QUADRUPLEX	60'
500 QUADRUPLEX	50'

**EFFECTIVE
DATE:
04-29-19**

**DISTRIBUTION CONSTRUCTION STANDARD
DOMINION ENERGY SOUTH CAROLINA, INC.**

SERVICE DETAILS

BY JALDATE 03-18-19REV. 2

06.01-02

REV. 2 (03/18/19) - CHANGED SCE&G TO COMPANY

OVERHEAD SERVICES

THE POINT OF ATTACHMENT AT THE HOUSE, BUILDING OR OTHER APPROVED POINT OF ATTACHMENT SHALL PROVIDE SUFFICIENT GROUND CLEARANCE AND BE OF SUFFICIENT STRENGTH TO SUPPORT THE MAXIMUM EXPECTED LOAD OF THE SERVICE CONDUCTORS. ALL SECONDARIES AND SERVICES SHALL MEET MINIMUM CLEARANCE REQUIREMENTS OVER ROOF, SIDEWALK AND/OR STREET (SEE DRAWINGS 01.02-01, 01.03-01A AND 01.03-01B).

WIRE HOLDERS SHALL BE FURNISHED BY THE COMPANY AND INSTALLED BY THE CUSTOMER. SEE DRAWING 06.01-07 FOR SERVICE ATTACHMENT DEVICES. SCREW-TYPE WIRE HOLDERS (HOUSE KNOBS) OR OTHER ATTACHMENTS (TOGGLE BOLT OR LAG BOLT) SHALL BE SECURELY ANCHORED INTO A STRUCTURAL MEMBER SUCH AS A STUD OR RAFTER OF WOOD FRAME BUILDINGS. POINTS OF ATTACHMENT INSTALLED IN BRICK OR BLOCK STRUCTURES SHALL EMPLOY THE USE OF LEAD-SHIELDS OR TOGGLE BOLTS. THESE DEVICES SHALL NOT BE INSTALLED IN MORTAR JOINTS; RATHER THEY SHALL BE INSTALLED INTO OR THROUGH THE BRICK OR BLOCK ITSELF.

UNDERGROUND AND HYBRID SERVICES

1. FOR SERVICE IN CONDUIT, THE CONDUIT SHALL BE INSTALLED 30 INCHES BELOW GRADE WITH A MINIMUM OF 36 INCH RADIUS SWEEPS. IF NECESSARY, CUSTOMER MUST MODIFY STRUCTURE FOOTING TO ALLOW 36 INCH RADIUS SWEEP.
2. NO MORE THAN THREE (3) 90 DEGREE BENDS ARE PERMITTED IN A SERVICE WITHOUT APPROVAL.
3. ALL CONDUIT SHALL BE ELECTRICAL GRADE SCHEDULE 40 PVC (GRAY).
4. 2 INCH CONDUIT IS REQUIRED FOR 200 AMP METERS.
5. 3 INCH CONDUIT IS REQUIRED FOR 201 - 600 AMP METERS.
6. SERVICE ROUTE MUST NOT BE IMPEDED BY DRIVEWAY, SIDEWALK OR OTHER OBSTRUCTION.
7. WEATHERHEAD IS REQUIRED IF SERVICE WIRE IS OWNED BY CUSTOMER.

MARKING OF PHASE ROTATION

ALL NEW THREE PHASE SERVICES SHALL BE MARKED TO IDENTIFY THE PHASE ROTATION. THIS SHALL BE ACCOMPLISHED BY USING A PHASE ROTATION METER (STOCK CODE 071.1200.0055) AND EITHER THE CLOCKWISE STICKER OR COUNTERCLOCKWISE STICKER SHOWN BELOW.

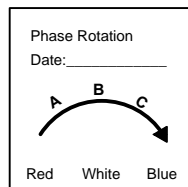

CLOCKWISE ROTATION
STOCK CODE: 080.7960.0120

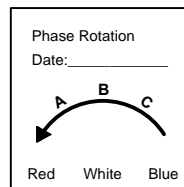

COUNTERCLOCKWISE ROTATION
STOCK CODE: 080.7960.0122

THE APPROPRIATE STICKER SHALL BE PLACED INSIDE THE METER BASE OR PAD MOUNTED TRANSFORMER. FOR OVERHEAD CT SERVICES, THE ROTATION SHALL BE CHECKED AT THE CT'S ON THE POLE AS FOLLOWS: TOP TO BOTTOM (RED, WHITE, BLUE), WITH THE HIGH LEG (IF PRESENT) IN THE BOTTOM CT. VERIFY THE ROTATION IN THE CT METER BASE AS FOLLOWS: LEFT TO RIGHT (RED TO RED, WHITE TO BLUE AND BLUE TO BLACK). ONCE VERIFIED, PLACE THE APPROPRIATE ROTATION STICKER INSIDE THE CT METER BASE.

DURING STORM TROUBLE SERVICE RESTORATION, REMOVE THE CUSTOMER'S METER AND USE A PHASE ROTATION METER TO ENSURE THE RECONNECTION WILL PROVIDE THE PROPER PHASE ROTATION FOR THAT CUSTOMER AS INDICATED BY THE STICKER. IN ADDITION, IF THE SERVICE IS DELTA, USE A VOLTMETER AT THE METER SOCKET TO ENSURE PROPER RECONNECTION OF THE HIGH LEG/POWER LEG CONDUCTOR.

EFFECTIVE
DATE:
04-29-19

DISTRIBUTION CONSTRUCTION STANDARD
DOMINION ENERGY SOUTH CAROLINA, INC.

MOBILE HOME OVERHEAD SERVICE NOTES

BY JAL DATE 03-18-19 REV. 1

06.03-01A

REV. 1 (03/18/19) - CHANGED SCE&G TO COMPANY

TO BE FURNISHED, INSTALLED AND MAINTAINED BY COMPANY:

<u>ITEM #</u>	<u>DESCRIPTION</u>
1	METER
2	PULLEY BRACKET
3	SERVICE (SOURCE) CONDUCTORS

TO BE FURNISHED, INSTALLED AND MAINTAINED BY CUSTOMER:

<u>ITEM #</u>	<u>DESCRIPTION</u>
4	CABINET AND CIRCUIT BREAKER(S)
5	CONDUIT (GALVANIZED IRON OR PVC) 2 INCH MIN DIAMETER
6	GROUND ROD (5/8" X 8' GALVANIZED OR COPPER CLAD)
7	PIPE STRAPS (SECURELY ATTACHING CONDUIT)
8	COPPER GROUND WIRE #6 MIN. (ALUMINUM NOT ACCEPTABLE)
9	SERVICE CONDUCTORS
10	METER SOCKET (RINGLESS AND UL APPROVED)
11	TREATED POLE (TIMBER NOT ACCEPTABLE FOR OVERHEAD SERVICE POLE)
12	CONDUIT SERVICE WEATHERHEAD

NOTES:

1. SOURCE SIDE CONNECTIONS IN METER SOCKET TO BE MADE BY COMPANY. LOAD SIDE CONNECTIONS IN METER SOCKET TO BE MADE BY CUSTOMER. (EXCEPTION: FOR OVERHEAD SERVICE THE CUSTOMER IS RESPONSIBLE FOR SOURCE AND LOAD SIDE CONNECTIONS).
2. WEATHERHEAD TO BE LOCATED NO LOWER THAN 6 INCHES BELOW PULLEY BRACKET, ITEM #2.
3. HEIGHT OF POLE MUST MEET NESC CLEARANCE REQUIREMENTS. (MINIMUM CLEARANCE IS 12 FEET FOR PEDESTRIAN TRAFFIC, 15.5 FEET FOR DRIVEWAY AND 16.5 FEET FOR TYPICAL ROADWAY).
4. METER POLE MUST BE SPOTTED BY COMPANY REPRESENTATIVE AND CAN NOT BE INSTALLED FURTHER THAN 125 FEET FROM COMPANY POLE/TRANSFORMER.
5. IF DOWN GUY AND ANCHOR IS REQUIRED THE CUSTOMER SHALL BE RESPONSIBLE TO FURNISH, INSTALL AND MAINTAIN.
6. GROUNDING CONDUCTOR (ITEM 8) TO BE SECURELY ATTACHED TO STRUCTURE.
7. ENTIRE ASSEMBLY TO MEET COMPANY, NEC AND LOCAL CODE REQUIREMENTS.
8. CALL PALMETTO UTILITIES PROTECTION SERVICE (PUPS) AT 811 BEFORE YOU DIG.

**EFFECTIVE
DATE:
04-29-19****DISTRIBUTION CONSTRUCTION STANDARD
DOMINION ENERGY SOUTH CAROLINA, INC.**

MOBILE HOME OVERHEAD SERVICE POLE

BY JAL

DATE 11-14-16

REV. 0

06.03-01B

FORMERLY DWG # MTR-MH, S2

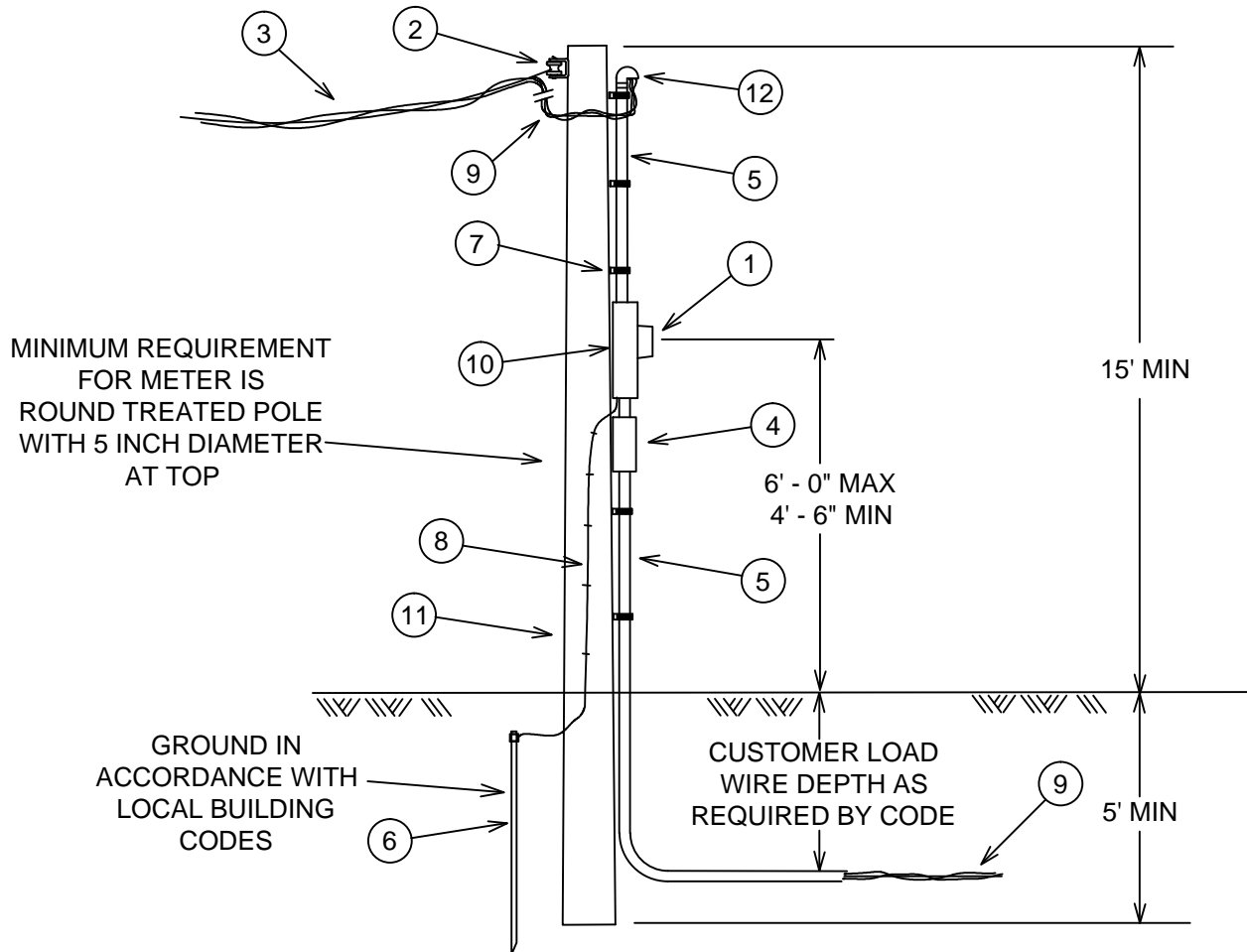

NOTES:

1. SEE DRAWING 06.03-01A FOR A LIST OF ITEMS AND NOTES.
2. SEE DRAWINGS 06.01-01 AND 06.01-02 FOR GENERAL INFORMATION AND NOTES.
3. SEE DRAWING 06.01-03 FOR MOBILE HOME SERVICE DETAILS.

EFFECTIVE DATE:
01-15-17

**DISTRIBUTION CONSTRUCTION STANDARD
DOMINION ENERGY SOUTH CAROLINA, INC.**

TEMPORARY OVERHEAD SERVICE NOTES

BY JAL DATE 03-18-19 REV. 1

06.03-02A

REV. 1 (03/18/19) - CHANGED SCE&G TO COMPANY

TO BE FURNISHED, INSTALLED AND MAINTAINED BY COMPANY:

<u>ITEM #</u>	<u>DESCRIPTION</u>
1	METER
2	PULLEY BRACKET
3	SERVICE (SOURCE) CONDUCTORS

TO BE FURNISHED, INSTALLED AND MAINTAINED BY CUSTOMER:

<u>ITEM #</u>	<u>DESCRIPTION</u>
4	CIRCUIT BREAKER(S) AND RECEPTACLES.
5	CONDUIT (GALVANIZED IRON OR PVC) 2 INCH MIN DIAMETER
6	GROUND ROD (5/8" X 8' GALVANIZED OR COPPER CLAD)
7	PIPE STRAPS (SECURELY ATTACHING CONDUIT)
8	COPPER GROUND WIRE #6 MIN. (ALUMINUM NOT ACCEPTABLE)
9	SERVICE CONDUCTORS (FROM WEATHERHEAD TO METER SOCKET)
10	METER SOCKET (RINGLESS AND UL APPROVED)
11	TREATED TIMBER/POLE (4 X 6 TIMBER OR 5 INCH DIAMETER @ POLE TOP MINIMUM)
12	CONDUIT SERVICE WEATHERHEAD
13	LUMBER (2 EACH - 2 X 4 MINIMUM) SECURELY FASTENED TO POLE AND STAKE

NOTES:

1. SOURCE AND LOAD SIDE CONNECTIONS IN METER SOCKET TO BE MADE BY CUSTOMER.
2. HEIGHT OF POLE MUST MEET NESC CLEARANCE REQUIREMENTS. (MINIMUM CLEARANCE IS 12 FEET FOR PEDESTRIAN TRAFFIC, 15.5 FEET FOR DRIVEWAY AND 16.5 FEET FOR TYPICAL ROADWAY).
3. TEMPORARY SERVICE POLE CAN NOT BE INSTALLED FURTHER THAN 125 FEET FROM COMPANY POLE/TRANSFORMER.
4. SERVICE ENTRANCE CONDUCTOR (ITEM 9) SHALL EXTEND MINIMUM OF 3 FEET OUT OF WEATHERHEAD.
5. POLE MUST SUPPORT COMPANY SERVICEMAN ON A LADDER. UNSAFE CONDITIONS ARE NOT ACCEPTABLE.
6. GROUNDING CONDUCTOR (ITEM 8) TO BE SECURELY ATTACHED TO STRUCTURE.
7. IF DOWN GUY AND ANCHOR ARE REQUIRED, THE CUSTOMER SHALL BE RESPONSIBLE TO FURNISH, INSTALL AND MAINTAIN.
8. ENTIRE ASSEMBLY TO MEET COMPANY, NEC AND LOCAL CODE REQUIREMENTS.
9. CALL PALMETTO UTILITIES PROTECTION SERVICE (PUPS) AT 811 BEFORE YOU DIG.

EFFECTIVE
DATE:
04-29-19**DISTRIBUTION CONSTRUCTION STANDARD
DOMINION ENERGY SOUTH CAROLINA, INC.**

TEMPORARY OVERHEAD SERVICE POLE

BY JAL

DATE 11-14-16

REV. 0

06.03-02B

FORMERLY DWG # MTR-T1, S2

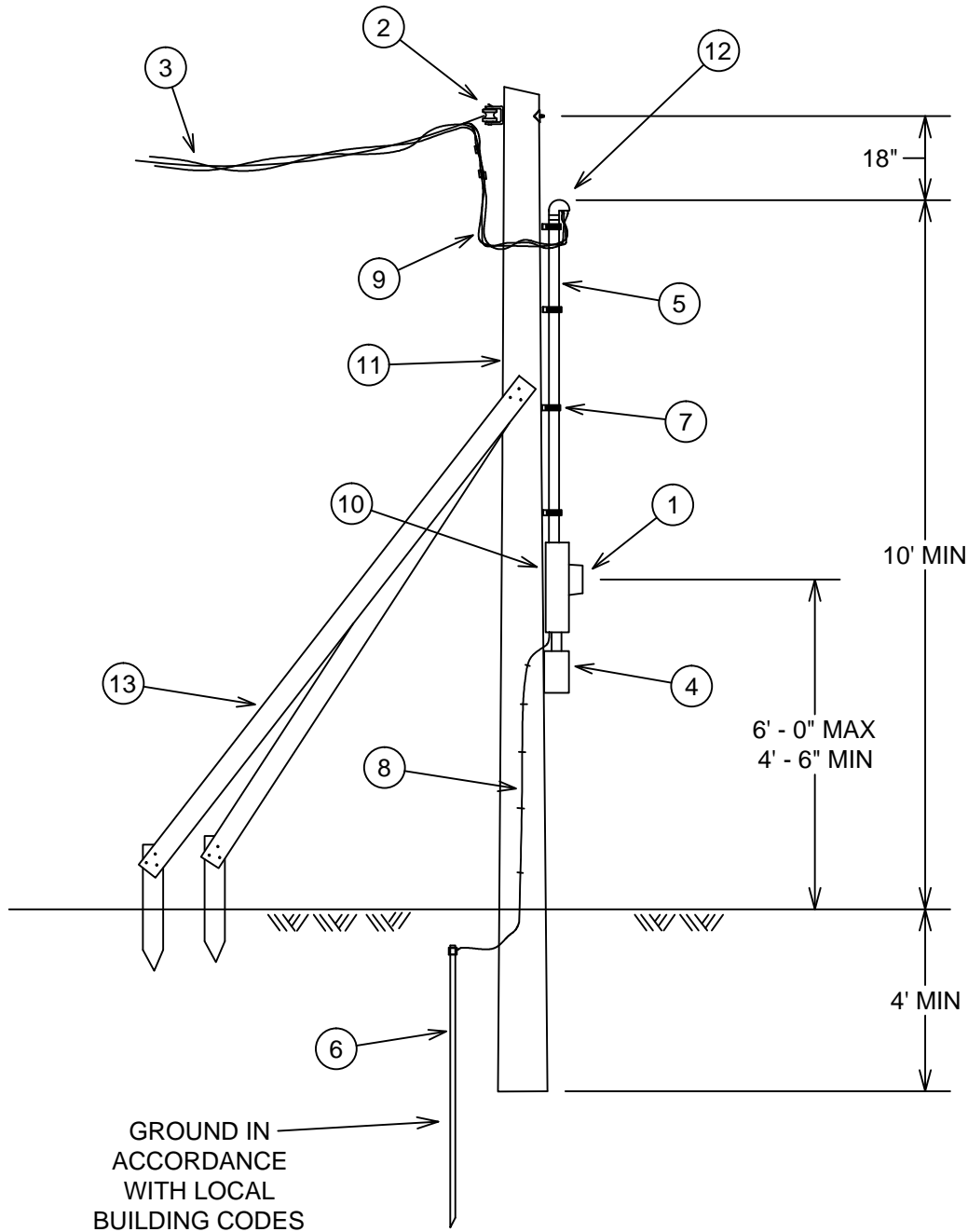

NOTES:

1. SEE DRAWING 06.03-02A FOR A LIST OF ITEMS AND NOTES.
2. SEE DRAWINGS 06.01-01 AND 06.01-02 FOR GENERAL INFORMATION AND NOTES.

**EFFECTIVE
DATE:
01-15-17**

**DISTRIBUTION CONSTRUCTION STANDARD
DOMINION ENERGY SOUTH CAROLINA, INC.**

RESIDENTIAL OVERHEAD SERVICE NOTES

BY JALDATE 03-18-19REV. 1

06.03-03A

REV. 1 (03/18/19) - CHANGED SCE&G TO COMPANY

NOTES:

1. SEE DRAWINGS 06.01-01 AND 06.01-02 FOR GENERAL INFORMATION AND NOTES.
2. CONTACT COMPANY TO HAVE FIELD PERSONNEL SPOT METER LOCATION BEFORE INSTALLING METER SOCKET. IF NOT LOCATED PROPERLY, CUSTOMER COULD BE REQUIRED TO RELOCATE.
3. METER SOCKET MUST BE INSTALLED ON LEFT OR RIGHT SIDE OF STRUCTURE TOWARD FRONT; REAR OF PROPERTY IS UNACCEPTABLE. SPOT TO BE DECIDED BY COMPANY BASED ON TRANSFORMER LOCATION.
4. COMPANY IS RESPONSIBLE FOR INSTALLATION AND MAINTENANCE OF OVERHEAD SERVICE CONDUCTOR AND METER. ALL OTHER MATERIALS, I.E., METER SOCKET, ENTRANCE WIRE AND CONDUIT, ARE THE RESPONSIBILITY OF THE CUSTOMER.
5. METER SOCKET AND CONDUIT MUST BE SECURELY ATTACHED TO STRUCTURE (REFERENCE THE ELECTRIC SERVICE AND METER INSTALLATIONS MANUAL, PARAGRAPH 520).
6. AT A MINIMUM, CONDUIT MUST BE ELECTRICAL GRADE SCHEDULE 40 GRAY PVC. IF SERVICE MAST IS INSTALLED THROUGH AND ABOVE ROOF LINE, IT MUST BE GALVANIZED IRON PIPE (ELECTRICAL METALLIC TUBING (EMT) IS UNACCEPTABLE). THE CONDUIT MUST BE SECURED AND OF ADEQUATE STRENGTH TO "WITHSTAND SAFELY THE STRAIN IMPOSED BY THE SERVICE DROP" (REFERENCE NEC 230.28)).
7. RECOMMENDED CONDUIT DIAMETER IS BASED ON ESTIMATED LOADING ON PIPE. ACTUAL LOADING VARIES WITH SERVICE LENGTH AND CONDUCTOR SIZE.
8. FOR MAST SERVICE, THE WEATHER HEAD SHALL BE LOCATED ABOVE POINT OF ATTACHMENT OF CONDUCTORS, AND SHALL NOT BE MORE THAN 4 FEET FROM ROOF EAVE (EDGE) OR FASCIA BOARD.
9. FOR HOUSE KNOB SERVICE, THE WEATHER HEAD SHALL BE NO MORE THAN 24 INCHES FROM POINT OF SERVICE (REFERENCE NEC 230.54 (C)).
10. IF USED, HOUSE KNOB IS TYPICALLY ATTACHED BY USE OF LAG SCREW. HOUSE KNOB (POINT OF ATTACHMENT) MUST BE SECURED AND OF ADEQUATE STRENGTH TO "WITHSTAND SAFELY THE STRAIN IMPOSED BY THE SERVICE DROP" (REFERENCE NEC 230.28).
11. SERVICE CABLE SHALL BE SUPPORTED WITHIN 12 INCHES OF WEATHER HEAD (REFERENCE NEC 230.51 (A)).
12. SEE DRAWING 06.01-07 FOR SERVICE ATTACHMENT DEVICES.
13. IF SERVICE IS 4 WIRE DELTA, HIGH-LEG MUST BE MARKED/IDENTIFIED AT WEATHER HEAD (REFERENCE NEC 230.56).
14. METER SOCKET MINIMUM/MAXIMUM HEIGHT IS ABOVE FINAL GRADE WITHIN 10 FEET OF METER.
15. ENTIRE ASSEMBLY TO MEET COMPANY, NEC AND LOCAL CODE REQUIREMENTS.

**EFFECTIVE
DATE:
04-29-19****DISTRIBUTION CONSTRUCTION STANDARD
DOMINION ENERGY SOUTH CAROLINA, INC.**

RESIDENTIAL OVERHEAD SERVICE (MAST)

BY JAL
 DATE 11-14-16
 REV. 0

06.03-03B

FORMERLY DWG # MTR-D, S3

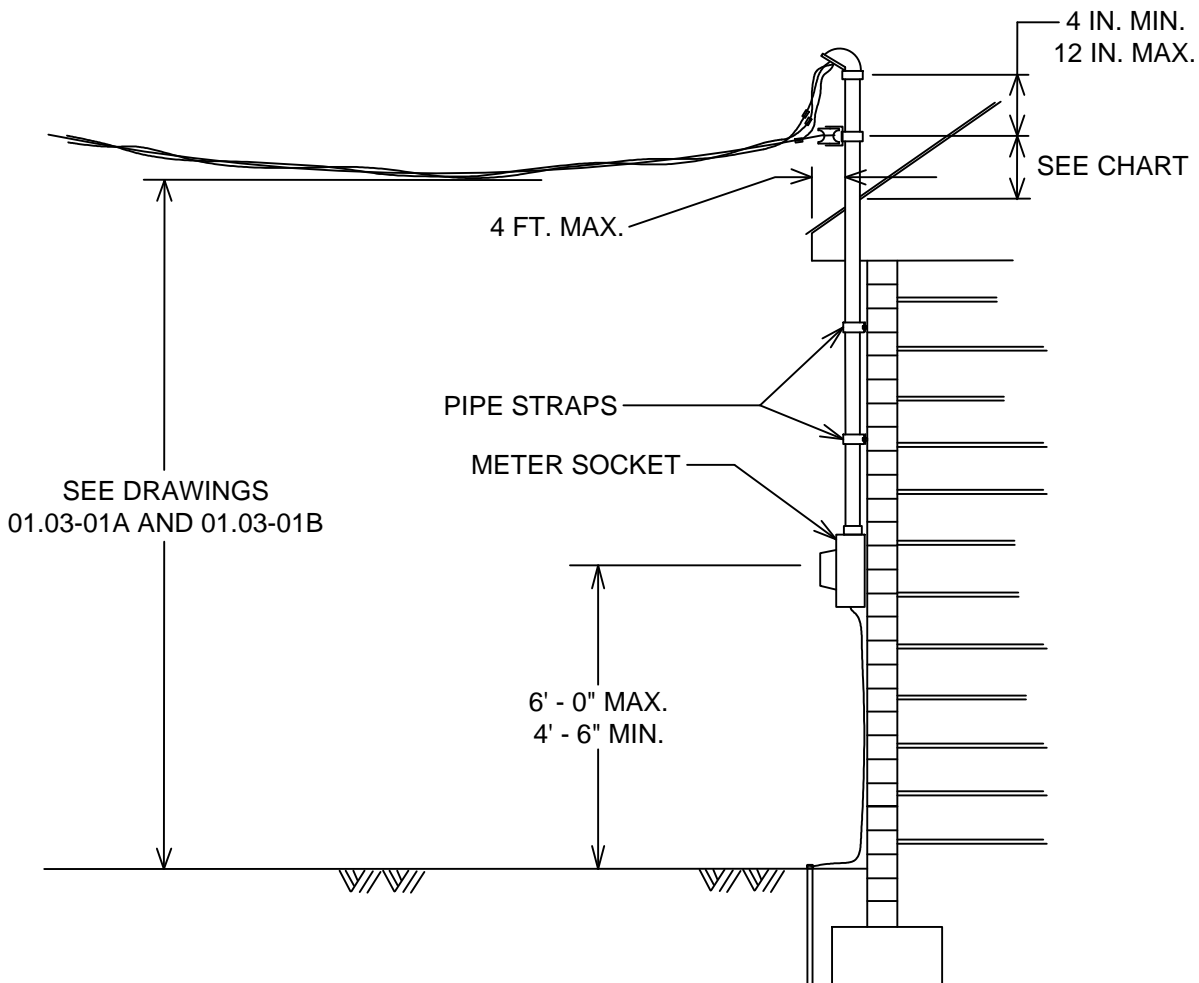

SEE DRAWINGS
01.03-01A AND 01.03-01B

MINIMUM CONDUIT DIAMETER	
HEIGHT ABOVE ROOF	CONDUIT SIZE
12" TO 24"	2"
24" TO 48"	2-1/2"
48" TO 84"	3"
84" TO 120"	3-1/2"

NOTE:
 1. SEE DRAWING 06.03-03A FOR GENERAL INFORMATION AND NOTES.

EFFECTIVE
 DATE:
 01-15-17

**DISTRIBUTION CONSTRUCTION STANDARD
 DOMINION ENERGY SOUTH CAROLINA, INC.**

RESIDENTIAL OVERHEAD SERVICE (HOUSE KNOB)

BY JAL

DATE 11-14-16

REV. 0

06.03-03C

FORMERLY DWG # MTR-D, S4

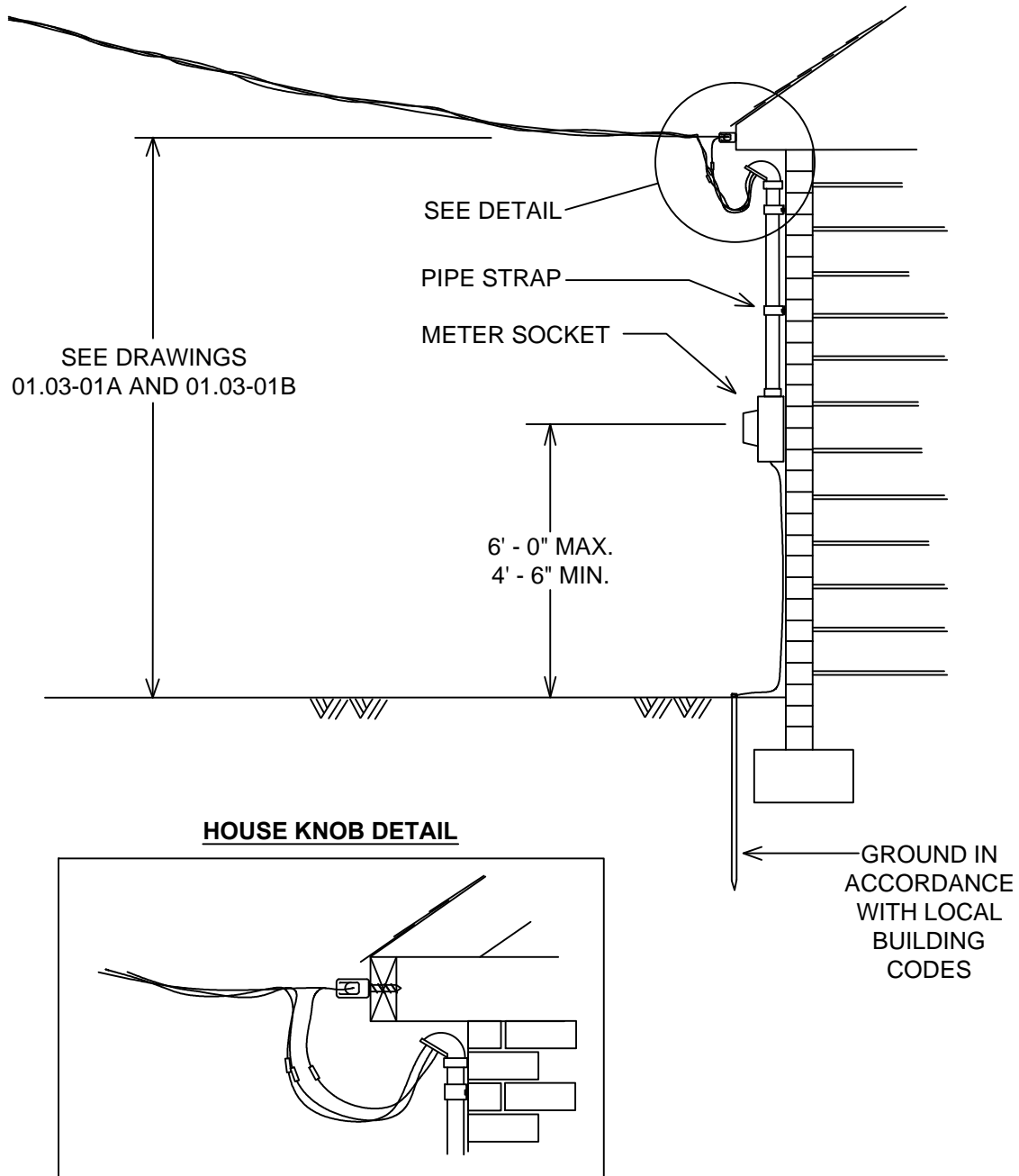

NOTE:

1. SEE DRAWING 06.03-03A FOR GENERAL INFORMATION AND NOTES.

EFFECTIVE
DATE:
01-15-17

**DISTRIBUTION CONSTRUCTION STANDARD
DOMINION ENERGY SOUTH CAROLINA, INC.**

MOBILE HOME UNDERGROUND SERVICE NOTES

BY JALDATE 03-18-19REV. 1

06.04-01A

REV. 1 (03/18/19) - CHANGED SCE&G TO COMPANY

TO BE FURNISHED, INSTALLED AND MAINTAINED BY COMPANY:

<u>ITEM #</u>	<u>DESCRIPTION</u>
1	METER
2	SERVICE (SOURCE) CONDUCTORS

TO BE FURNISHED, INSTALLED AND MAINTAINED BY CUSTOMER:

<u>ITEM #</u>	<u>DESCRIPTION</u>
3	CABINET AND CIRCUIT BREAKER(S)
4	CONDUIT (GALVANIZED IRON OR PVC) 2 INCH MIN DIAMETER
5	GROUND ROD (5/8" X 8' GALVANIZED OR COPPER CLAD)
6	PIPE STRAPS (SECURELY ATTACHING CONDUIT)
7	COPPER GROUND WIRE #6 MIN. (ALUMINUM NOT ACCEPTABLE)
8	SERVICE CONDUCTORS
9	METER SOCKET (RINGLESS AND UL APPROVED)
10	TREATED TIMBER / POLE
11	ADDRESS OR LOT NUMBER (PERMANENTLY MARKED ON METER SOCKET COVER)

NOTES:

1. SOURCE SIDE CONNECTIONS IN METER SOCKET TO BE MADE BY COMPANY. LOAD SIDE CONNECTIONS IN METER SOCKET TO BE MADE BY CUSTOMER.
2. METER POLE MUST BE SPOTTED BY COMPANY REPRESENTATIVE AND CANNOT BE INSTALLED FURTHER THAN 125 FEET FROM COMPANY POLE/TRANSFORMER.
3. GROUNDING CONDUCTOR (ITEM 7) TO BE SECURELY ATTACHED TO STRUCTURE.
4. ENTIRE ASSEMBLY TO MEET COMPANY, NEC AND LOCAL CODE REQUIREMENTS.
5. CALL PALMETTO UTILITIES PROTECTION SERVICE (PUPS) AT 811 BEFORE YOU DIG.

**EFFECTIVE
DATE:
04-29-19****DISTRIBUTION CONSTRUCTION STANDARD
DOMINION ENERGY SOUTH CAROLINA, INC.**

MOBILE HOME UNDERGROUND SERVICE PEDESTAL

BY JAL

DATE 03-18-19

REV. 1

06.04-01B

REV. 1 (03/18/19) - CHANGED SCE&G TO COMPANY

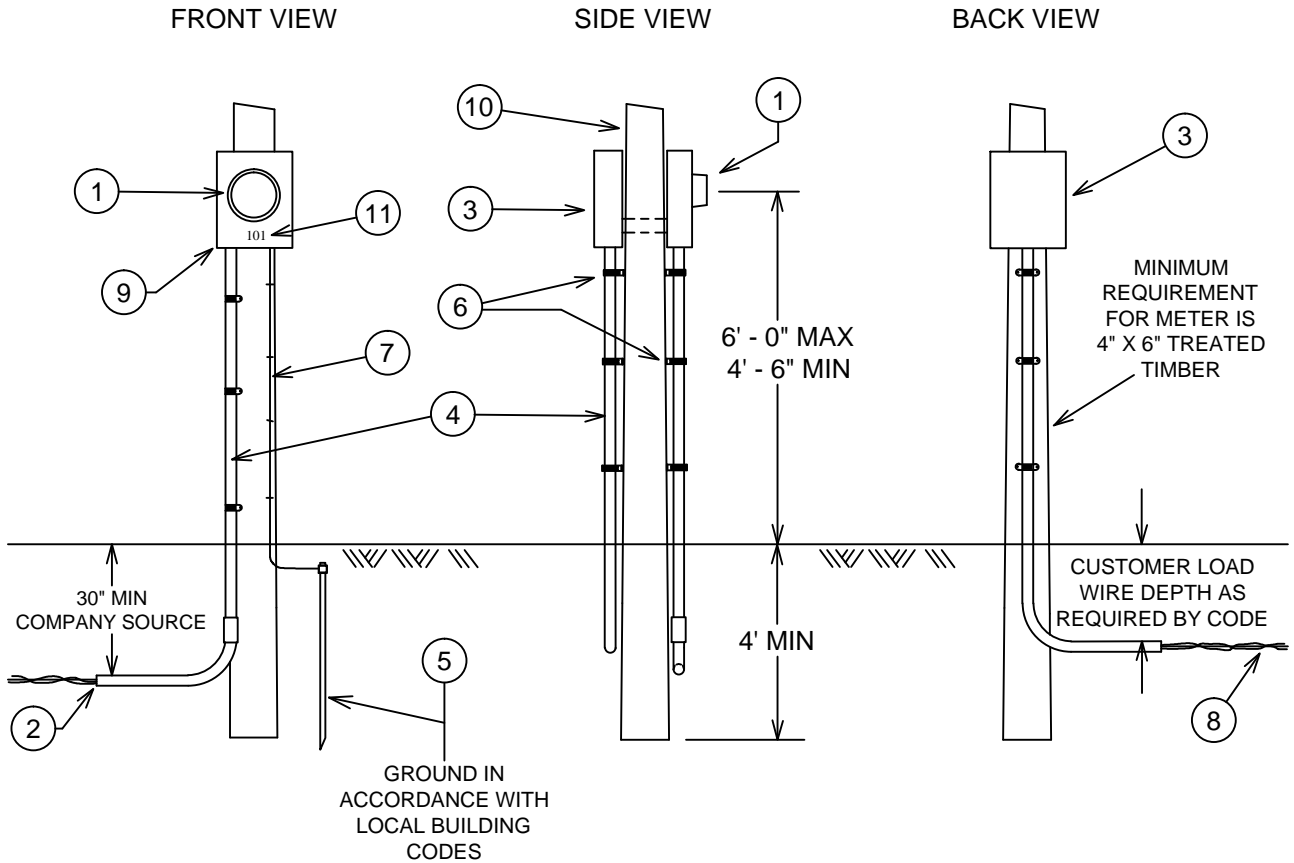

NOTES:

1. SEE DRAWING 06.04-01A FOR A LIST OF ITEMS AND NOTES.
2. SEE DRAWINGS 06.01-01 AND 06.01-02 FOR GENERAL INFORMATION AND NOTES.
3. SEE DRAWING 06.01-03 FOR MOBILE HOME SERVICE DETAILS.

EFFECTIVE DATE:
04-29-19

DISTRIBUTION CONSTRUCTION STANDARD
DOMINION ENERGY SOUTH CAROLINA, INC.

TEMPORARY UNDERGROUND SERVICE NOTES

BY JALDATE 03-18-19REV. 2

06.04-02A

REV. 2 (03/18/19) - CHANGED SCE&G TO COMPANY

TO BE FURNISHED, INSTALLED AND MAINTAINED BY COMPANY:

<u>ITEM #</u>	<u>DESCRIPTION</u>
1	METER
2	PAD MOUNTED TRANSFORMER

TO BE FURNISHED, INSTALLED AND MAINTAINED BY CUSTOMER:

<u>ITEM #</u>	<u>DESCRIPTION</u>
3	CIRCUIT BREAKER(S) AND RECEPTACLES
4	CONDUIT (GALVANIZED IRON OR PVC) 2 INCH MIN DIAMETER
5	GROUND ROD (5/8" X 8' GALVANIZED OR COPPER CLAD)
6	PIPE STRAPS (SECURELY ATTACHING CONDUIT)
7	COPPER GROUND WIRE #6 MIN. (ALUMINUM NOT ACCEPTABLE)
8	SERVICE CONDUCTORS #4 MIN.-#2 MAX. (FROM TRANSFORMER TO METER SOCKET)
9	METER SOCKET (RINGLESS AND UL APPROVED)
10	CONDUIT SERVICE WEATHERHEAD
11	TREATED TIMBER / POLE (4X4 TIMBER OR 5 INCH DIAMETER AT POLE TOP MINIMUM)

NOTES:

1. SOURCE AND LOAD SIDE CONNECTIONS IN METER SOCKET TO BE MADE BY CUSTOMER.
2. TEMPORARY SERVICE POLE TO BE INSTALLED FRONT (DOOR/PAD LOCK) RIGHT SIDE OF TRANSFORMER AND NO CLOSER THAN FOUR (4) FEET.
3. TEMPORARY SERVICE POLE CAN BE CONNECTED AT SECONDARY HANDHOLE OR PEDESTAL.
4. CUSTOMER TO INSTALL SERVICE CONDUCTOR (ITEM 8) MINIMUM OF 12 INCHES BELOW GRADE AND TO WITHIN ONE (1) FOOT OF POINT OF SERVICE (I.E., TRANSFORMER). WITHIN ONE (1) FOOT OF TRANSFORMER, COMPANY REQUIRES AN ADDITIONAL 10 FEET OF SERVICE CONDUCTOR TO MAKE CONNECTIONS.
5. GROUNDING CONDUCTOR (ITEM 7) TO BE SECURELY ATTACHED TO STRUCTURE.
6. ENTIRE ASSEMBLY TO MEET COMPANY, NEC AND LOCAL CODE REQUIREMENTS.
7. CALL PALMETTO UTILITIES PROTECTION SERVICE (PUPS) AT 811 BEFORE YOU DIG.

EFFECTIVE
DATE:
04-29-19**DISTRIBUTION CONSTRUCTION STANDARD
DOMINION ENERGY SOUTH CAROLINA, INC.**

TEMPORARY UNDERGROUND SERVICE POLE / PEDESTAL

BY JAL

DATE 11-14-16

REV. 0

06.04-02B

FORMERLY DWG # MTR-T2, S2

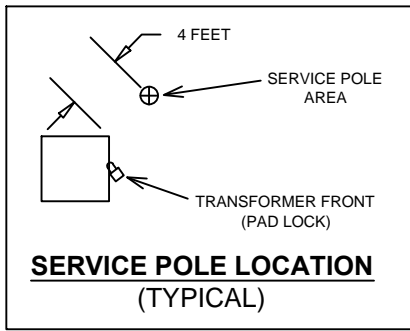

POLE

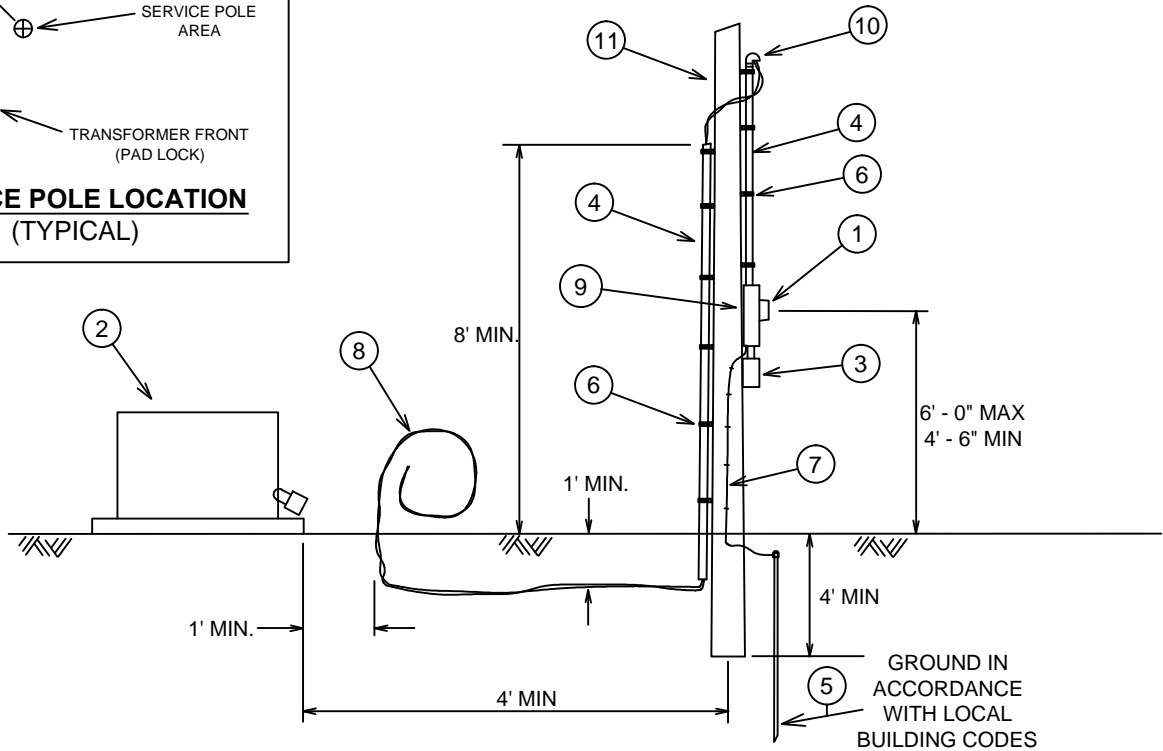

PEDESTAL

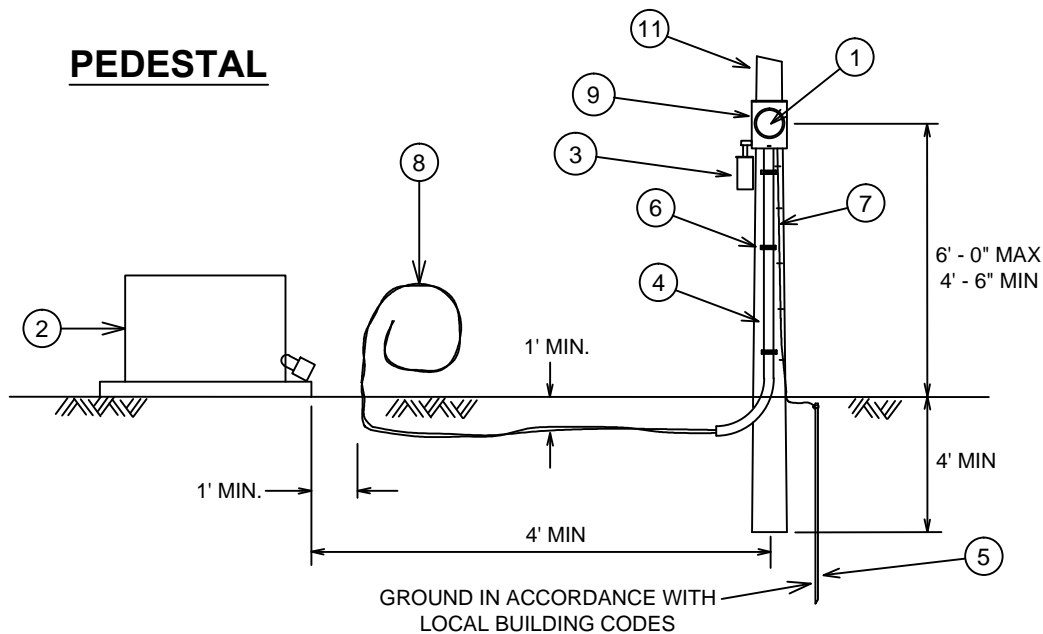

NOTES:

1. SEE DRAWING 06.04-02A FOR A LIST OF ITEMS AND NOTES.
2. SEE DRAWINGS 06.01-01 AND 06.01-02 FOR GENERAL INFORMATION AND NOTES.

EFFECTIVE DATE:
01-15-17

DISTRIBUTION CONSTRUCTION STANDARD
DOMINION ENERGY SOUTH CAROLINA, INC.

HYBRID SERVICE

BY JAL

DATE 03-18-19

REV. 2

06.04-03A

RISER CONDUCTOR	MACRO	CONDUIT
4/0 AL TRIPLEX	MSD2	2"
300 AL TRIPLEX	MSD3	3"

REV. 2 (03/18/19) - CHANGED SCE&G TO COMPANY; UPDATED NOTES

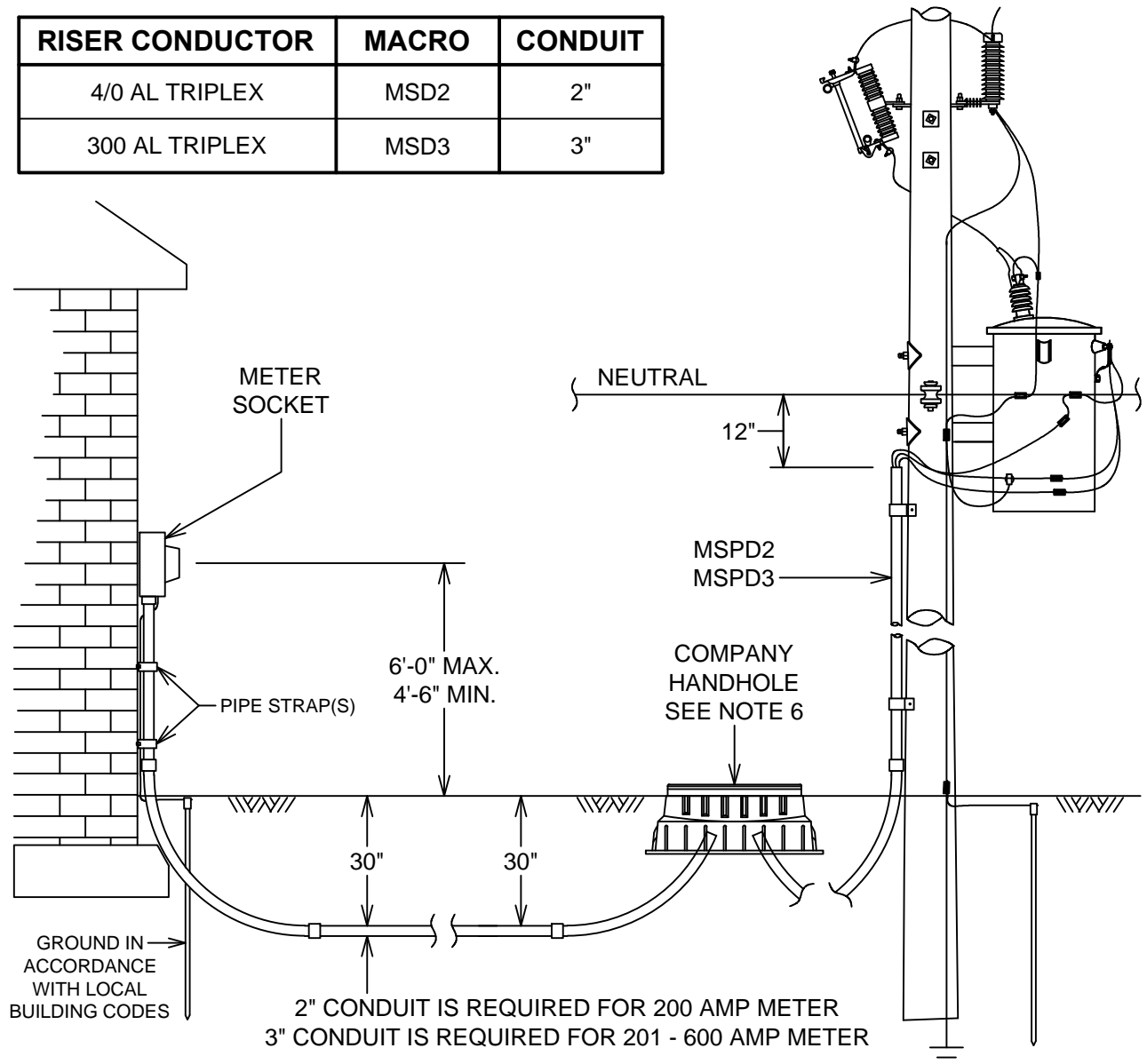

NOTES:

1. SEE DRAWINGS 06.01-01 AND 06.01-02 FOR GENERAL INFORMATION AND NOTES.
2. FOR SERVICE IN CONDUIT, THE CONDUIT SHALL BE INSTALLED 30 INCHES BELOW GRADE WITH A MINIMUM OF 36 INCH RADIUS SWEEPS. IF NECESSARY, CUSTOMER MUST MODIFY STRUCTURE FOOTING TO ALLOW 36 INCH RADIUS SWEEP.
3. ALL CONDUIT SHALL BE ELECTRICAL GRADE GRAY SCHEDULE 40 PVC.
4. NO MORE THAN THREE (3) 90 DEGREE BENDS ARE PERMITTED IN A SERVICE RUN.
5. SEE DRAWINGS 15.01-05A AND 15.01-05B FOR SECONDARY CABLE IDENTIFICATION.
6. HANDHOLE LOCATION DETERMINED BY COMPANY REPRESENTATIVE. HANDHOLE AND UNDERGROUND CONNECTORS ARE NOT INCLUDED IN MACRO. SEE SECTION 13 FOR SECONDARY ENCLOSURES AND HANDHOLES.
7. SEE DRAWING 06.04-03B FOR CONVERTING OVERHEAD TO UNDERGROUND SERVICE.
8. SEE DRAWING 07.02-01 FOR REQUIRED FOREIGN ATTACHMENT CLEARANCES.

EFFECTIVE DATE:
04-29-19

DISTRIBUTION CONSTRUCTION STANDARD
DOMINION ENERGY SOUTH CAROLINA, INC.

RESIDENTIAL HYBRID SERVICE OH TO UG CONVERSION

BY JAL
DATE 03-19-19
REV. 2

06.04-03B

REV. 2 (03/19/19) - CHANGED SCE&G TO COMPANY

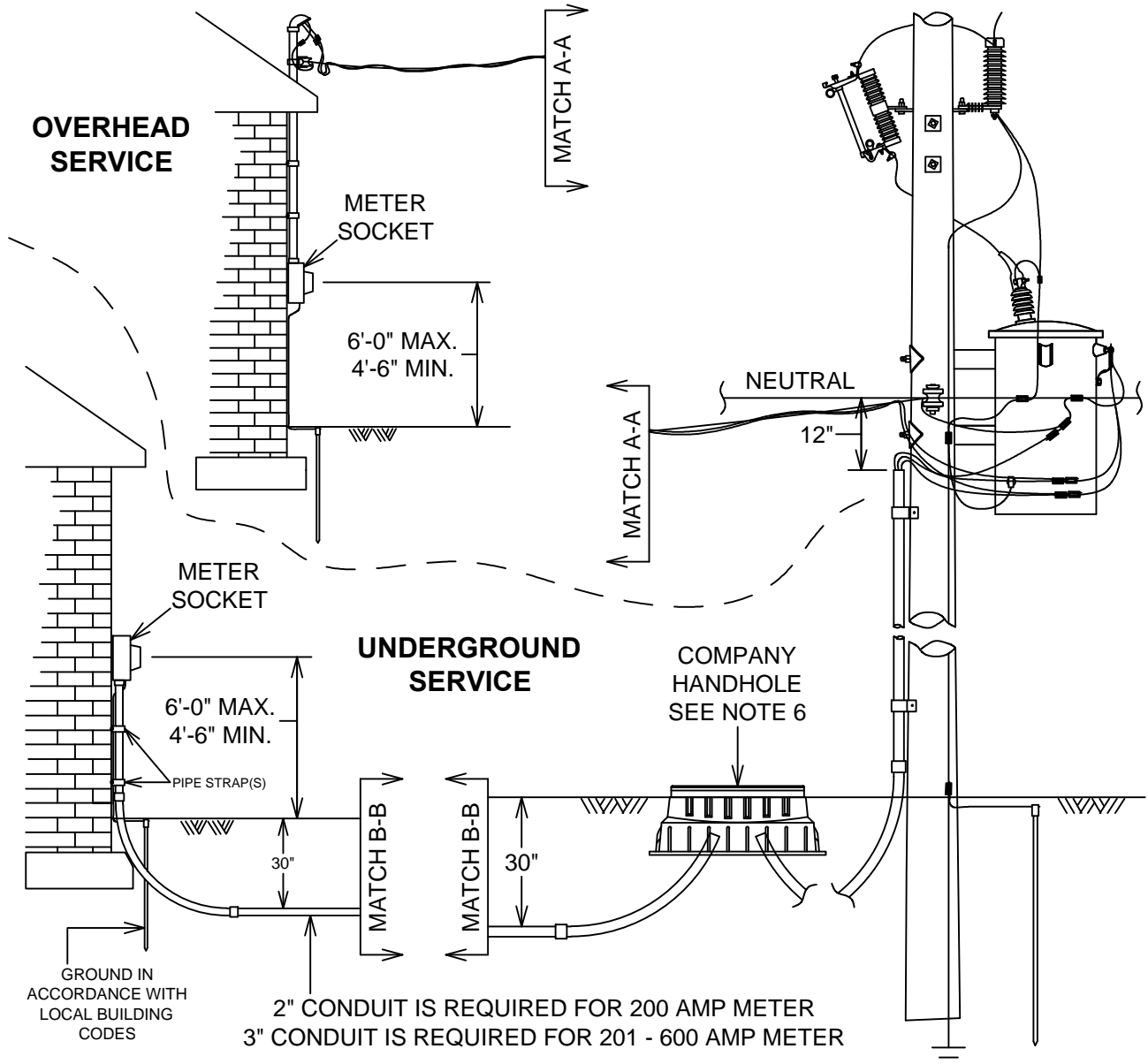

NOTES:

1. SEE DRAWINGS 06.01-01 AND 06.01-02 FOR GENERAL INFORMATION AND NOTES.
2. FOR SERVICE IN CONDUIT, THE CONDUIT SHALL BE INSTALLED 30 INCHES BELOW GRADE WITH A MINIMUM OF 36 INCH RADIUS SWEEPS. IF NECESSARY, CUSTOMER MUST MODIFY STRUCTURE FOOTING TO ALLOW 36 INCH RADIUS SWEEP.
3. ALL CONDUIT SHALL BE ELECTRICAL GRADE GRAY SCHEDULE 40 PVC.
4. NO MORE THAN THREE (3) 90 DEGREE BENDS ARE PERMITTED IN A SERVICE RUN.
5. COMPANY WILL INSTALL UNDERGROUND CONDUCTOR. RESIDENTIAL "CUSTOMER OWNED" WIRE IS UNACCEPTABLE.
6. HANDHOLE LOCATION DETERMINED BY COMPANY REPRESENTATIVE. SEE SECTION 13 FOR SECONDARY ENCLOSURES AND HANDHOLES.
7. INSTALLATION MUST CONFORM TO COMPANY, NEC, NESC AND LOCAL CODE REQUIREMENTS.
8. SEE DRAWING 07.02-01 FOR REQUIRED FOREIGN ATTACHMENT CLEARANCES.

**EFFECTIVE
DATE:
04-29-19**

**DISTRIBUTION CONSTRUCTION STANDARD
DOMINION ENERGY SOUTH CAROLINA, INC.**

UNDERGROUND SERVICE

BY JAL
 DATE 03-19-19
 REV. 0

06.04-03C

FORMERLY DWG # MTR-D, S2

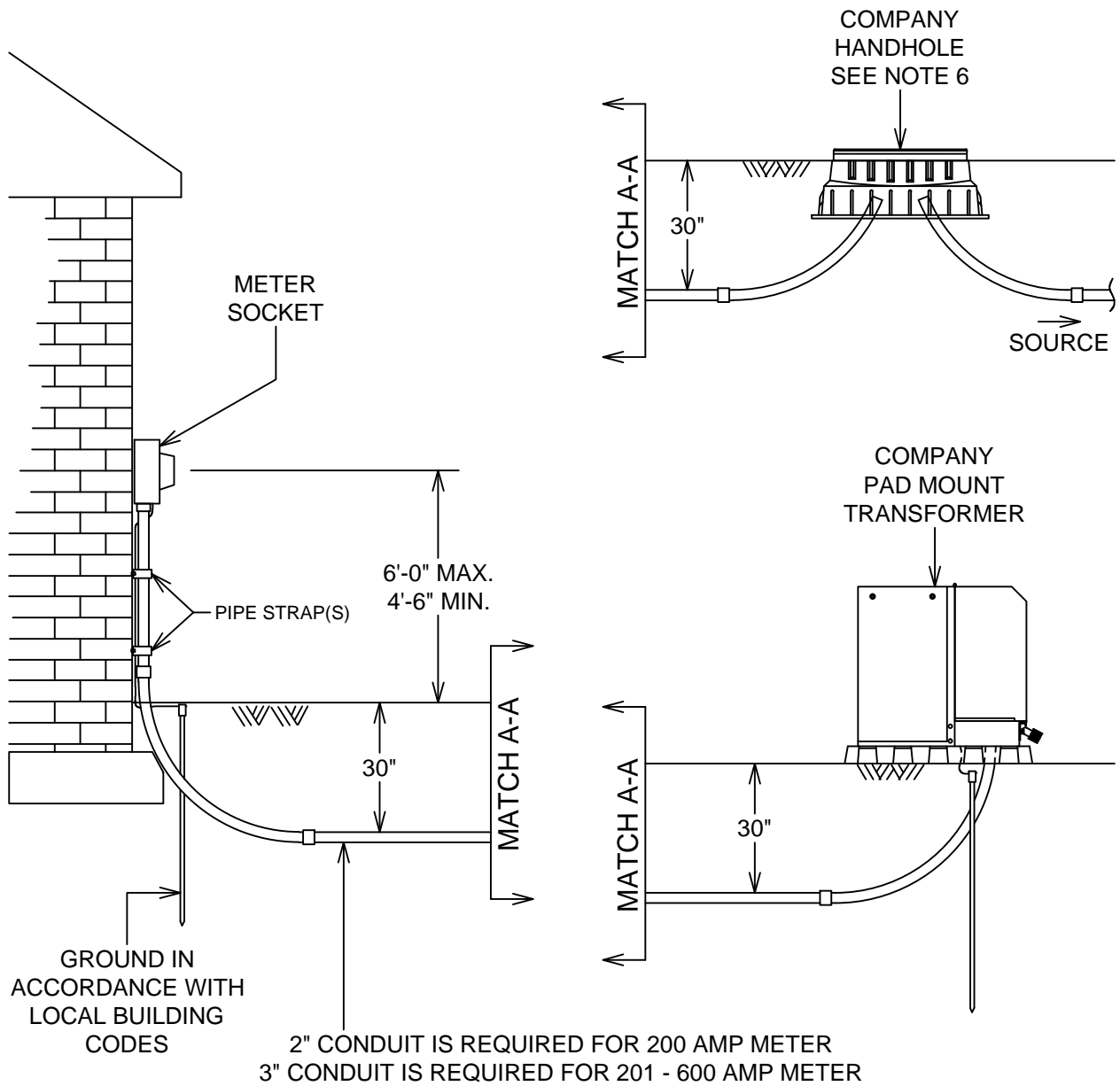

NOTES:

1. SEE DRAWINGS 06.01-01 AND 06.01-02 FOR GENERAL INFORMATION AND NOTES.
2. FOR SERVICE IN CONDUIT, THE CONDUIT SHALL BE INSTALLED 30 INCHES BELOW GRADE WITH A MINIMUM OF 36 INCH RADIUS SWEEPS. IF NECESSARY, CUSTOMER MUST MODIFY STRUCTURE FOOTING TO ALLOW 36 INCH RADIUS SWEEP.
3. ALL CONDUIT SHALL BE ELECTRICAL GRADE GRAY SCHEDULE 40 PVC.
4. NO MORE THAN THREE (3) 90 DEGREE BENDS ARE PERMITTED IN A SERVICE RUN.
5. SEE DRAWINGS 15.01-05A AND 15.01-05B FOR SECONDARY CABLE IDENTIFICATION.
6. HANDHOLE LOCATION DETERMINED BY COMPANY REPRESENTATIVE. SEE SECTION 13 FOR SECONDARY ENCLOSURES AND HANDHOLES.

EFFECTIVE
 DATE:
 04-29-19

DISTRIBUTION CONSTRUCTION STANDARD
DOMINION ENERGY SOUTH CAROLINA, INC.

COMMUNICATION UNDERGROUND SERVICE

BY JAL
DATE 03-20-19
REV. 1

06.04-05

REV. 1 (03/20/19) - CHANGED SCE&G TO COMPANY

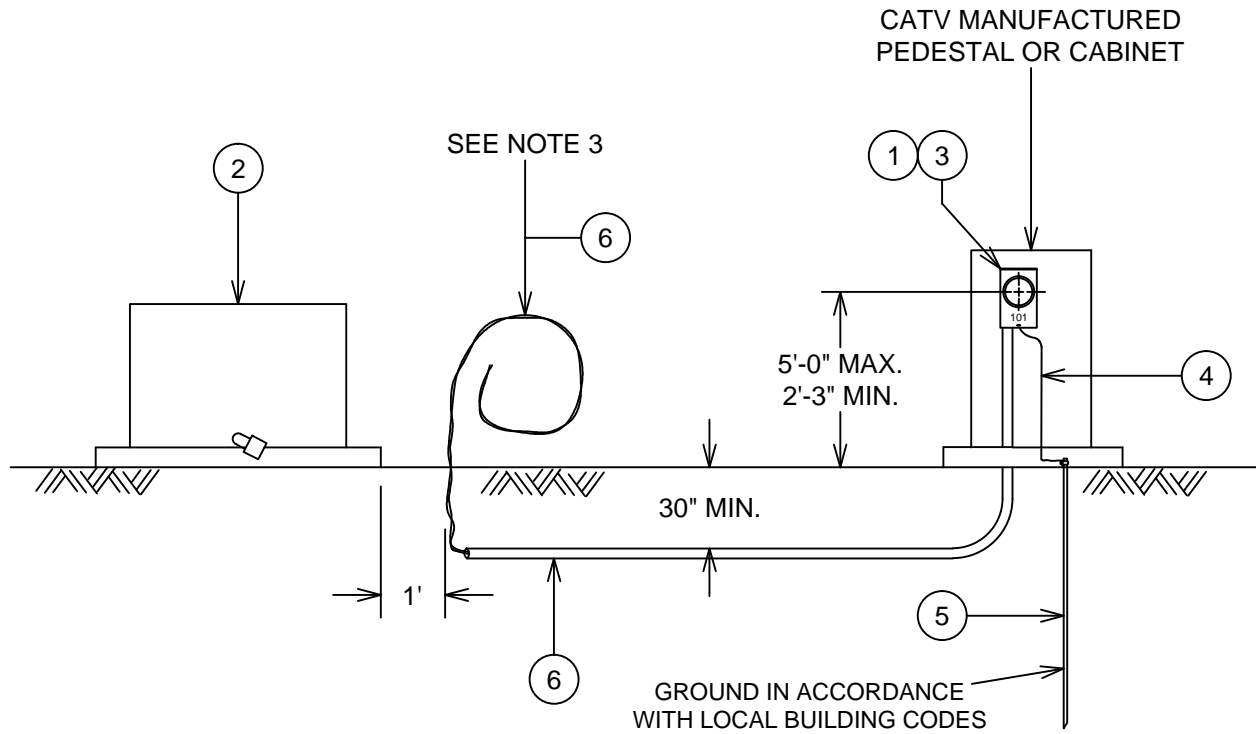

TO BE FURNISHED, INSTALLED AND MAINTAINED BY COMPANY

<u>ITEM #</u>	<u>DESCRIPTION</u>
1	METER
2	TRANSFORMER, PEDESTAL OR HANDHOLE

TO BE FURNISHED, INSTALLED AND MAINTAINED BY CUSTOMER

<u>ITEM #</u>	<u>DESCRIPTION</u>
3	METER SOCKET (RINGLESS AND UL APPROVED)
4	COPPER GROUND WIRE (#6 MIN. - ALUMINUM NOT ACCEPTABLE)
5	GROUND ROD (5/8" X 8' COPPER CLAD)
6	CONDUIT AND SERVICE CONDUCTOR

NOTES:

1. ADDRESS OR LOT NUMBER TO BE PERMANENTLY MARKED ON COVER OF METER SOCKET.
2. CUSTOMER MUST INSTALL CONDUIT AND SERVICE CONDUCTOR WITHIN ONE (1) FOOT OF COMPANY FACILITY (ITEM #2).
3. ADDITIONAL SERVICE CONDUCTOR, 10 FEET MINIMUM, IS REQUIRED FOR CONNECTING TO COMPANY FACILITY (ITEM #2).
4. BONDING SHALL BE PROVIDED BETWEEN ALL ABOVE GROUND METALLIC POWER AND COMMUNICATIONS APPARATUS THAT ARE SEPARATED BY A DISTANCE OF 6 FEET OR LESS (REFERENCE NESC 384C).

**EFFECTIVE
DATE:
04-29-19**

**DISTRIBUTION CONSTRUCTION STANDARD
DOMINION ENERGY SOUTH CAROLINA, INC.**

METER SOCKETS

BY JAL

DATE 03-20-19

REV. 2

19.01-01

REV. 2 (03/20/19) - CHANGED SCE&G TO COMPANY

METER SOCKETS

METER SOCKETS ARE FURNISHED, INSTALLED AND MAINTAINED BY THE CUSTOMER. ALL METER SOCKETS SHALL BE RINGLESS, HAVE UL APPROVAL, AND COMPLY WITH ANSI C12.7 SPECIFICATIONS.

METER SOCKETS SHALL BE INSTALLED WHERE READILY ACCESSIBLE (REFERENCE SECTION 5 OF THE ELECTRIC SERVICE AND METER INSTALLATIONS MANUAL). METER SOCKET LOCATIONS SHALL BE APPROVED BY A COMPANY REPRESENTATIVE PRIOR TO INSTALLATION. 100 AMP METER SOCKETS ARE FOR LOW CURRENT APPLICATIONS ONLY (TEMPORARY SERVICES, CATV AMPLIFIER SERVICES, TRAFFIC SIGNAL LIGHTS, AND BILLBOARD SERVICES).

METER SOCKET CONNECTIONS

ALL NEW 100 AMP AND 200 AMP SELF-CONTAINED METER SOCKETS MAY BE EQUIPPED WITH LAY-IN MECHANICAL TERMINALS OR STUDS FOR ONE-HOLE COMPRESSION LUGS. COMPRESSION LUGS ARE PROVIDED BY THE CUSTOMER AND SHALL BE APPROVED BY THE COMPANY (SEE SECTION 14). ALL FOUR-GANG OR LARGER METER SOCKETS SHALL HAVE TWO (2) LAY-IN CONNECTIONS ON EACH TERMINAL IN THE CENTER WIRING COMPARTMENT.

OVERHEAD SERVICE: SOURCE AND LOAD WIRES ARE TERMINATED IN METER SOCKET BY THE CUSTOMER.

UNDERGROUND SERVICE: CONDUIT TERMINATES AT METER SOCKET ON BOTTOM LEFT OR BOTTOM RIGHT (NEVER IN THE CENTER); SOURCE WIRES ARE TERMINATED BY COMPANY; LOAD WIRES ARE TERMINATED BY THE CUSTOMER.

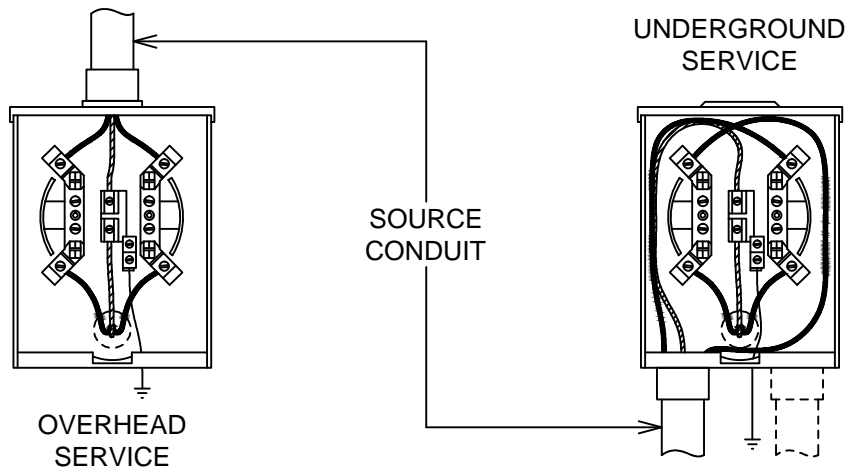

NOTES:

1. ALL INSTALLATIONS SHALL MEET COMPANY, NEC AND LOCAL CODE REQUIREMENTS.
2. SOURCE CONDUCTORS SHALL ALWAYS BE TERMINATED IN THE TOP SIDE OF THE METER. FOR CUSTOMER GENERATION APPLICATIONS, I.E., SOLAR, COMPANY IS ALWAYS THE SOURCE/LINE AND THE CUSTOMER IS ALWAYS THE LOAD.
3. METER SOCKETS FOR UNDERGROUND MUST BE SIZED TO ACCOMMODATE THE BEND RADIUS OF THE CONDUCTORS BEING INSTALLED (REFERENCE NEC TABLE 312.6(B)).
4. METERED AND UNMETERED CONDUCTORS SHALL NOT OCCUPY THE SAME RACEWAY.
5. ONLY COMPANY OWNED EQUIPMENT IS ALLOWED IN METER SOCKET.

EFFECTIVE
DATE:
04-29-19

DISTRIBUTION CONSTRUCTION STANDARD
DOMINION ENERGY SOUTH CAROLINA, INC.

METER CLEARANCE REQUIREMENTS

BY JAL

DATE 07-10-17

REV. 1

19.01-03

REV. 1 (07/10/17) - ADDED GAS METERS TO NOTE 3

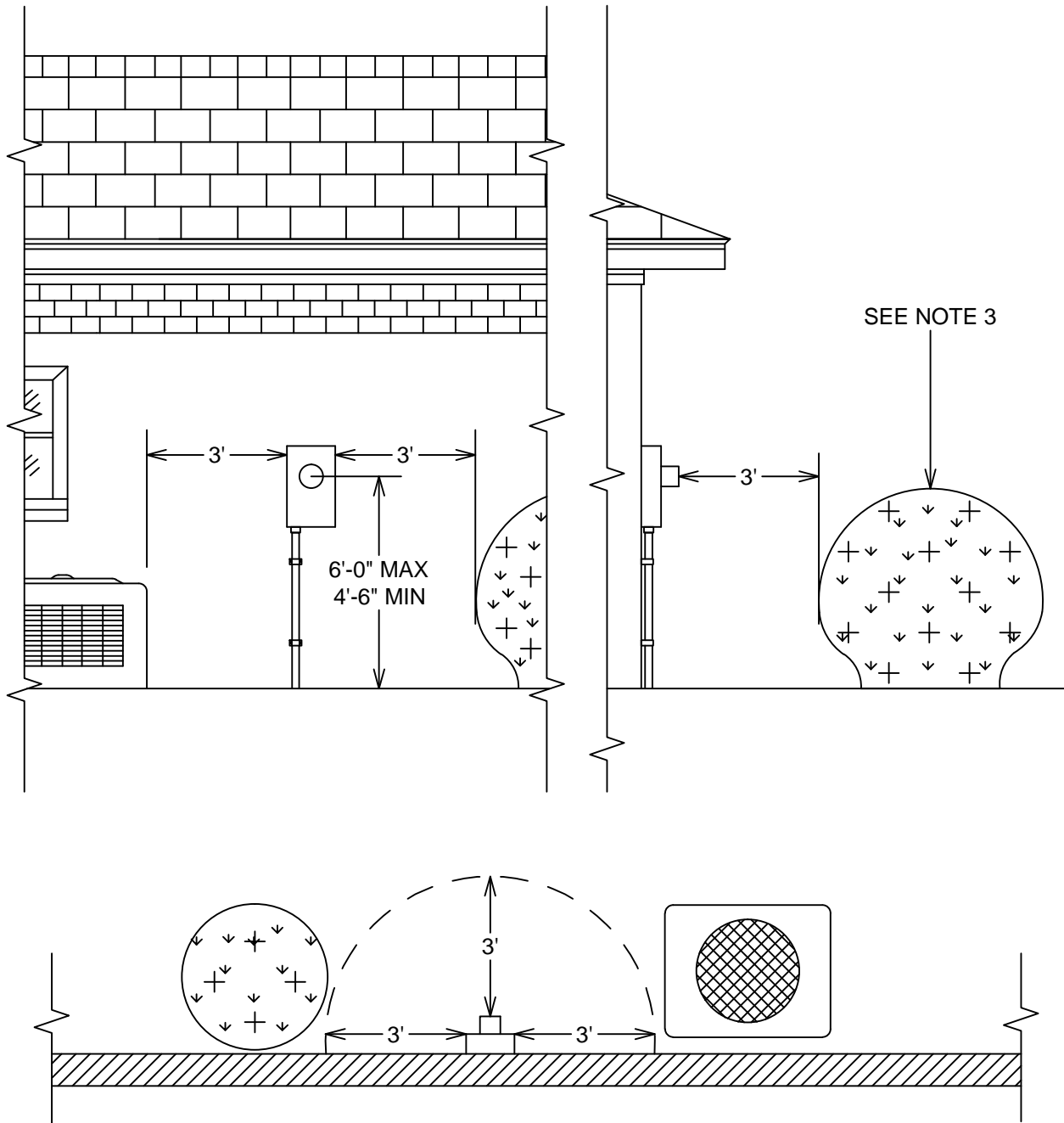

NOTES:

1. SEE DRAWING 19.01-01 FOR GENERAL INFORMATION AND NOTES.
2. PERMANENT AND/OR TEMPORARY OBSTRUCTIONS ARE NOT PERMITTED WITHIN THREE FEET IN ANY DIRECTION OF AN ELECTRIC METER.
3. OBSTRUCTIONS INCLUDE, BUT ARE NOT LIMITED TO TREES, SHRUBS, HVAC UNITS, GENERATORS, WALLS, FENCES, GAS METERS AND/OR BUILDINGS.
4. SEE DRAWING 19.01-05 FOR GANGED METER SOCKETS.

EFFECTIVE DATE:
06-05-17

**DISTRIBUTION CONSTRUCTION STANDARD
DOMINION ENERGY SOUTH CAROLINA, INC.**

METER SOCKET MOUNTING CONFIGURATIONS

BY JAL

DATE 05-03-17

REV. 0

19.01-04

FORMERLY DWG # PMTR-5

BUILDING

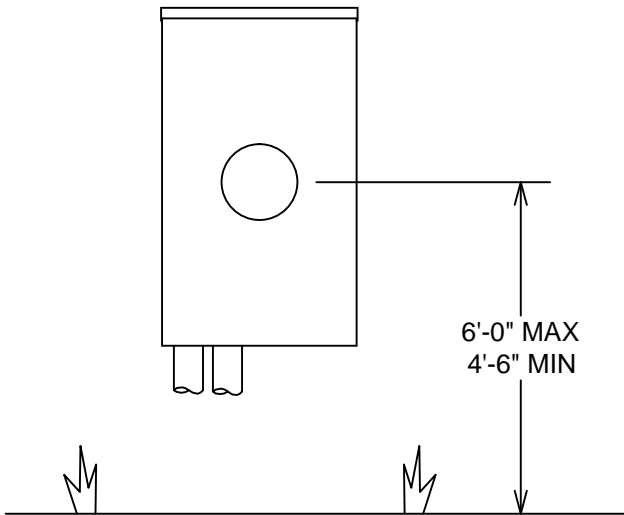

FOR STEEL BUILDINGS, UNISTRUT BRACING ATTACHED TO STRUCTURAL COMPONENT (VERT/HORIZ) IS REQUIRED

FREE-STANDING MASONRY WALL

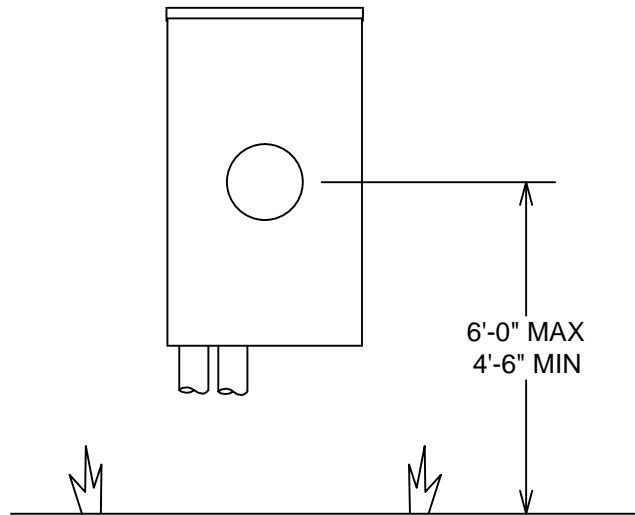

MINIMUM WALL DIMENSIONS:
 HEIGHT = 84"
 WIDTH = 30"
 THICKNESS = 8"

POLE

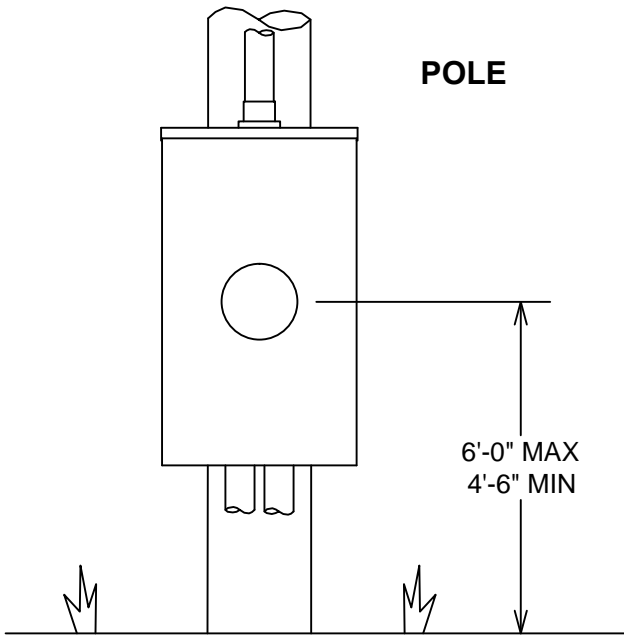

FREE-STANDING ANGLE IRON OR TREATED TIMBERS

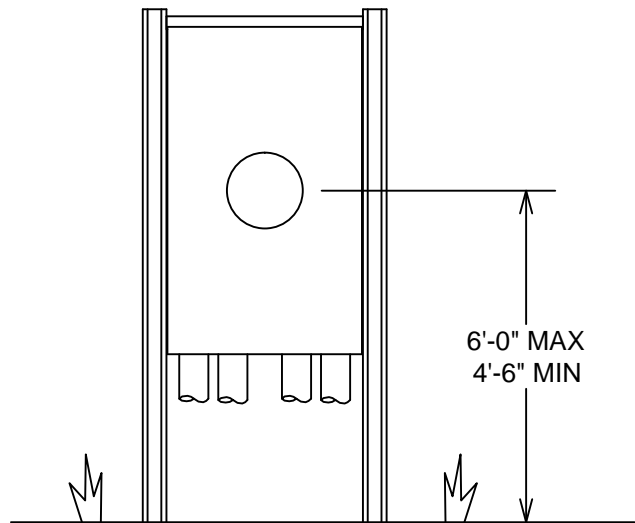

MINIMUM 2-1/2" X 2-1/2" X 1/4" ANGLE IRON OR 4" X 4" TREATED TIMBERS

NOTE:

1. SEE DRAWING 19.01-01 FOR GENERAL INFORMATION AND NOTES.

EFFECTIVE DATE:
06-05-17

**DISTRIBUTION CONSTRUCTION STANDARD
 DOMINION ENERGY SOUTH CAROLINA, INC.**

MODULAR (GANGED) METER ASSEMBLY

BY JAL

DATE 03-20-19

REV. 1

19.01-05

REV. 1 (03/20/19) - CHANGED SCE&G TO COMPANY

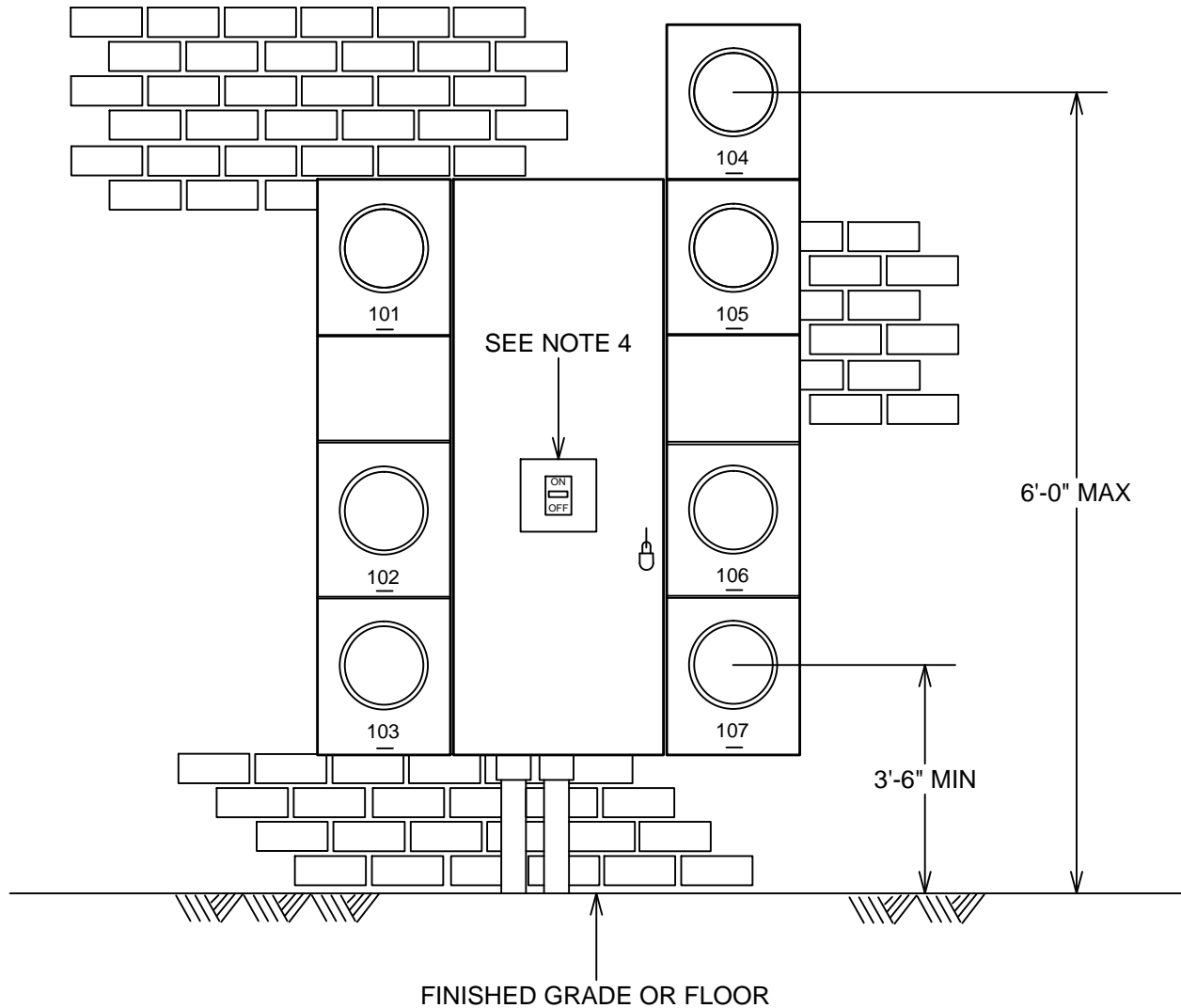

NOTES:

1. SEE DRAWING 19.01-01 FOR GENERAL INFORMATION AND NOTES.
2. EACH METER SOCKET SHALL BE PLAINLY AND PERMANENTLY MARKED, I.E., STENCILED WITH ENAMEL PAINT, WITH UNIT NUMBER OR OTHER DESCRIPTION ON THE INSIDE OF THE METER SOCKET AND ON THE OUTSIDE OF THE METER SOCKET COVER.
3. COMPANY PERSONNEL SHALL VERIFY THE UNIT NUMBER OR OTHER DESCRIPTION MATCHES WHAT IS STENCILED BEFORE SETTING A METER.
4. COMPANY CANNOT ATTACH TO MAIN BREAKER OR DISCONNECT DEVICE. IF INSTALLED, CUSTOMER CONNECTION POINT WILL BE A HANDHOLE OR OTHER DESIGNATED LOCATION.

EFFECTIVE
DATE:
04-29-19

DISTRIBUTION CONSTRUCTION STANDARD
DOMINION ENERGY SOUTH CAROLINA, INC.

SINGLE-PHASE 120V 2W METER

BY JAL

DATE 04-24-17

REV. 0

19.02-01

FORMERLY DWG # MTR-1, S1

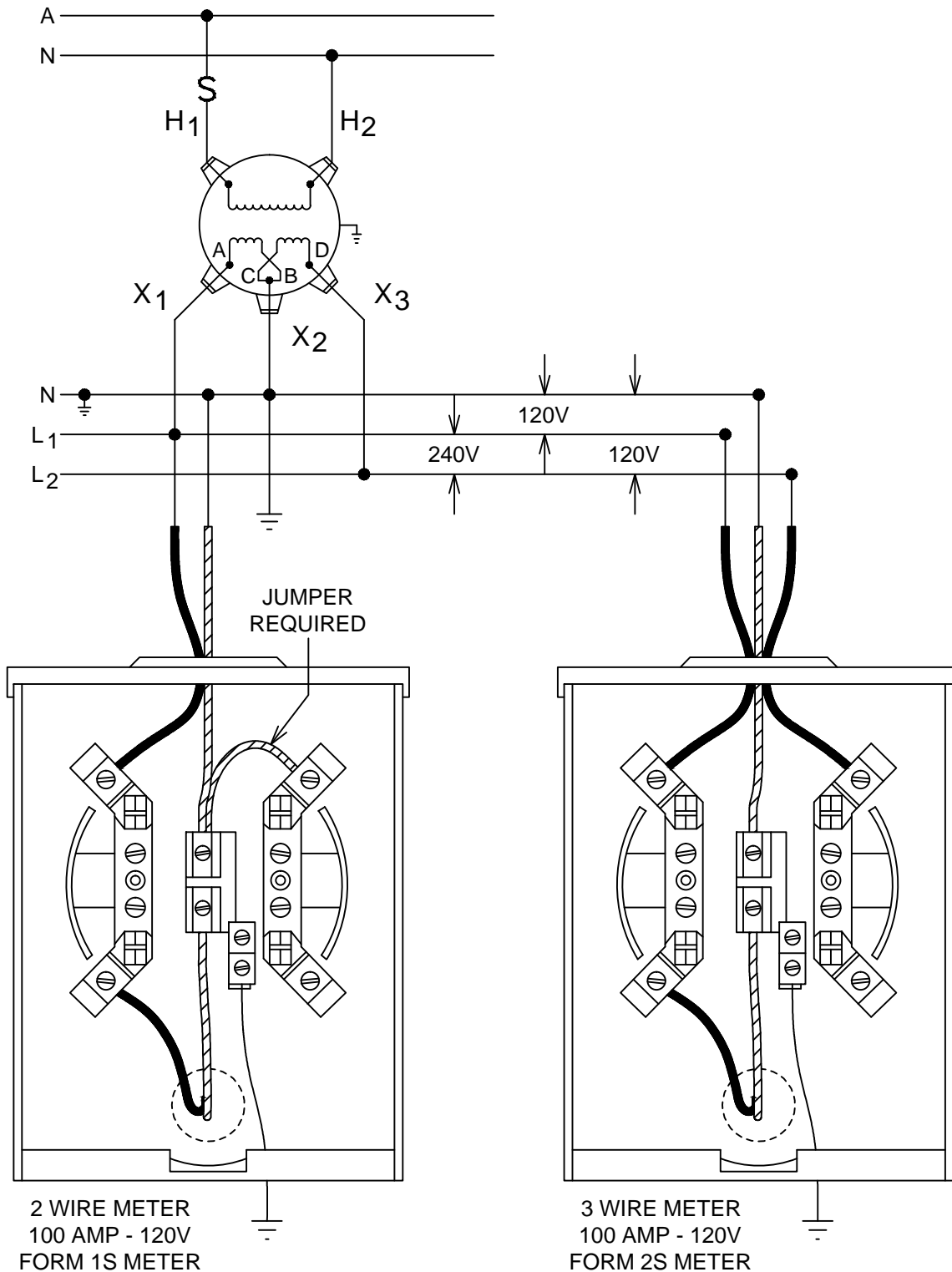

NOTE:

1. SEE DRAWING 19.01-01 FOR GENERAL INFORMATION AND NOTES.

EFFECTIVE
DATE:
06-05-17

DISTRIBUTION CONSTRUCTION STANDARD
DOMINION ENERGY SOUTH CAROLINA, INC.

SINGLE-PHASE 120/240V
3W METER (200 AMPS)

BY JAL

DATE 04-24-17

REV. 0

19.02-02A

FORMERLY DWG # MTR-1, S1

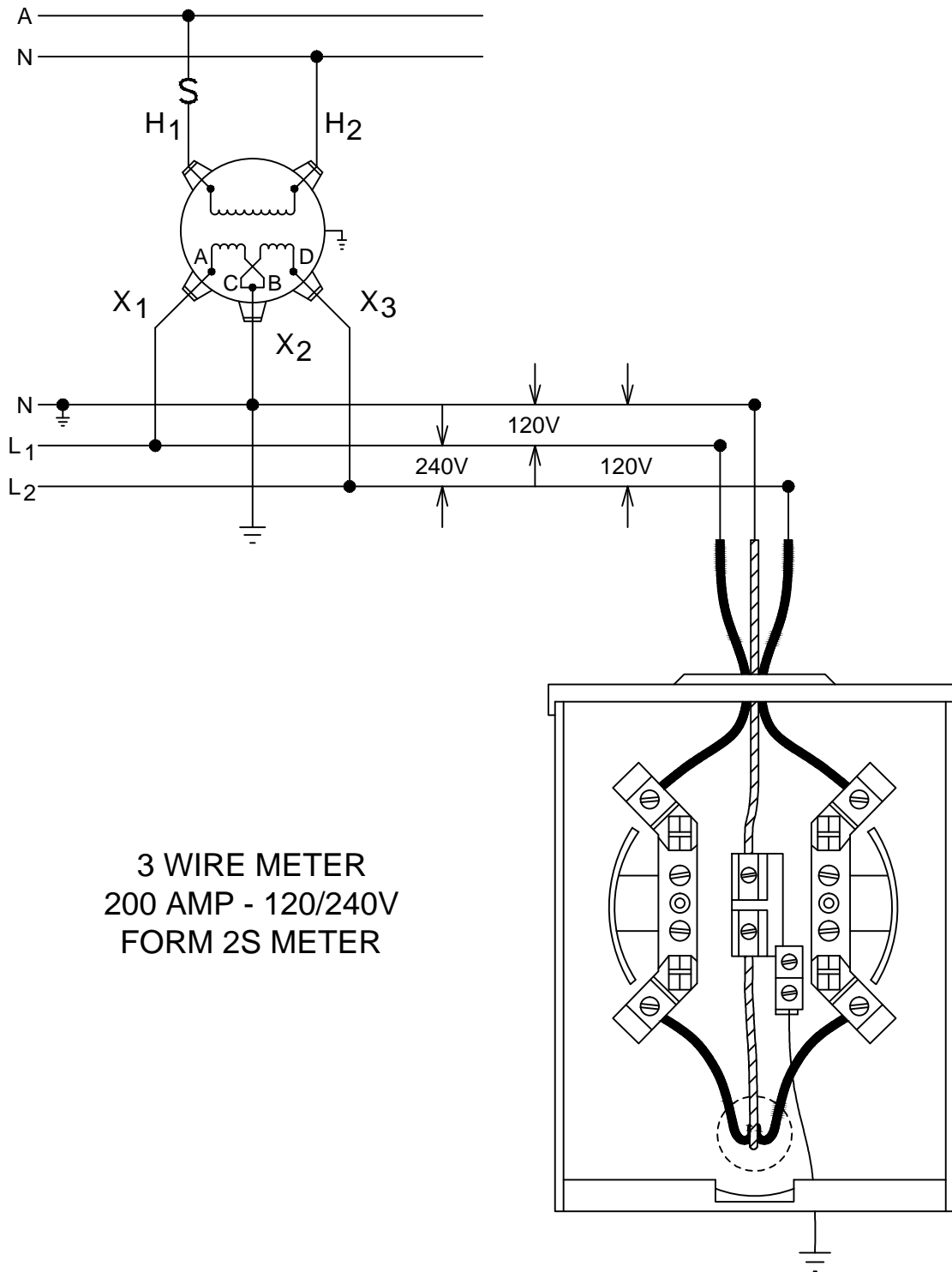

3 WIRE METER
200 AMP - 120/240V
FORM 2S METER

NOTE:

1. SEE DRAWING 19.01-01 FOR GENERAL INFORMATION AND NOTES.

EFFECTIVE
DATE:
06-05-17

DISTRIBUTION CONSTRUCTION STANDARD
DOMINION ENERGY SOUTH CAROLINA, INC.

SINGLE-PHASE 120/240V 3W METER (201 - 600 AMPS)

BY JAL
DATE 04-24-17
REV. 0

19.02-02B

FORMERLY DWG # MTR-1, S1 & S2

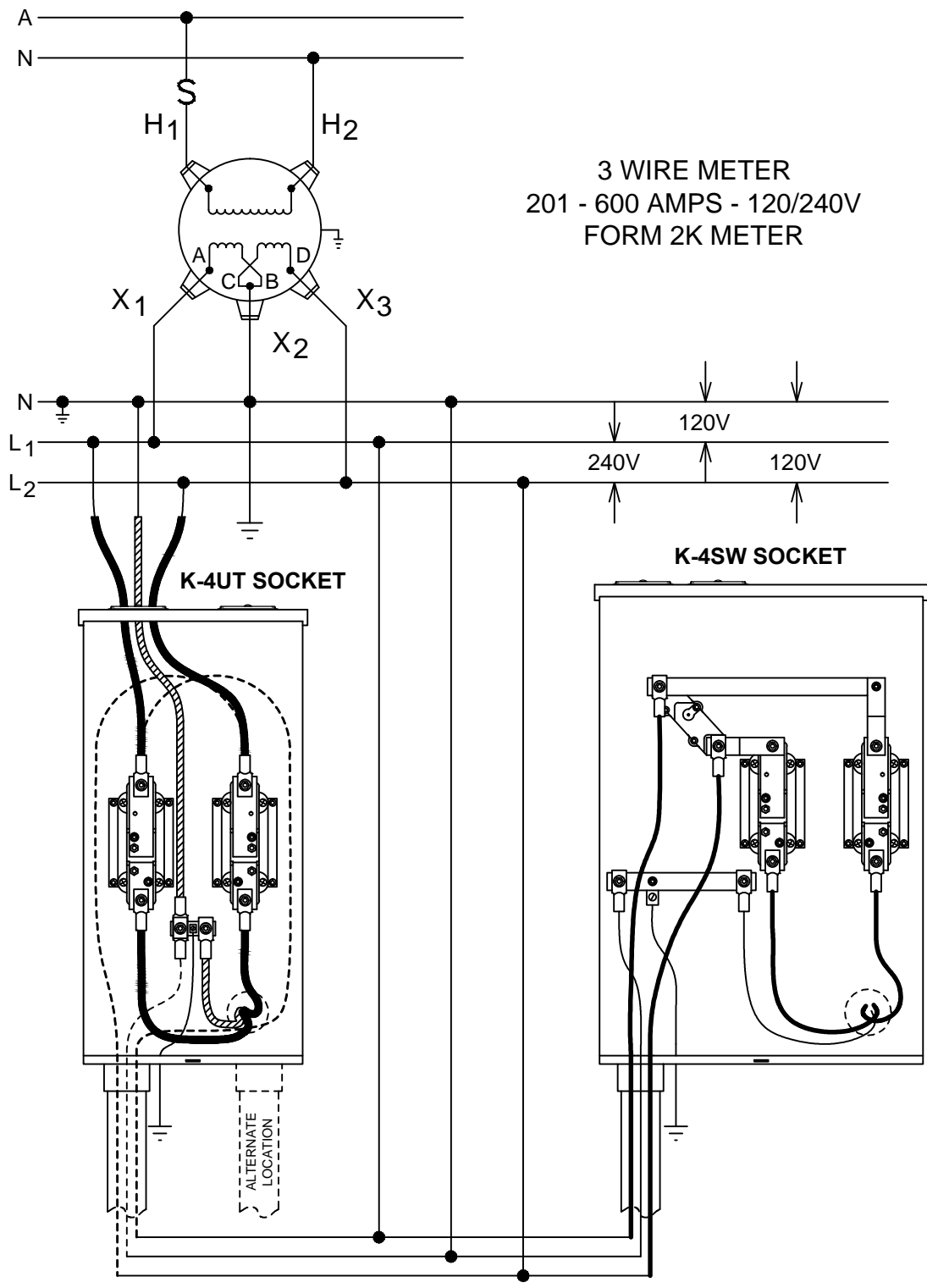

NOTE:
1. SEE DRAWING 19.01-01 FOR GENERAL INFORMATION AND NOTES.

EFFECTIVE
DATE:
06-05-17

**DISTRIBUTION CONSTRUCTION STANDARD
DOMINION ENERGY SOUTH CAROLINA, INC.**

SINGLE-PHASE 240/480V 3W METER (200 AMPS)

BY JAL

DATE 04-24-17

REV. 0

19.02-03

FORMERLY DWG # MTR-2, S3

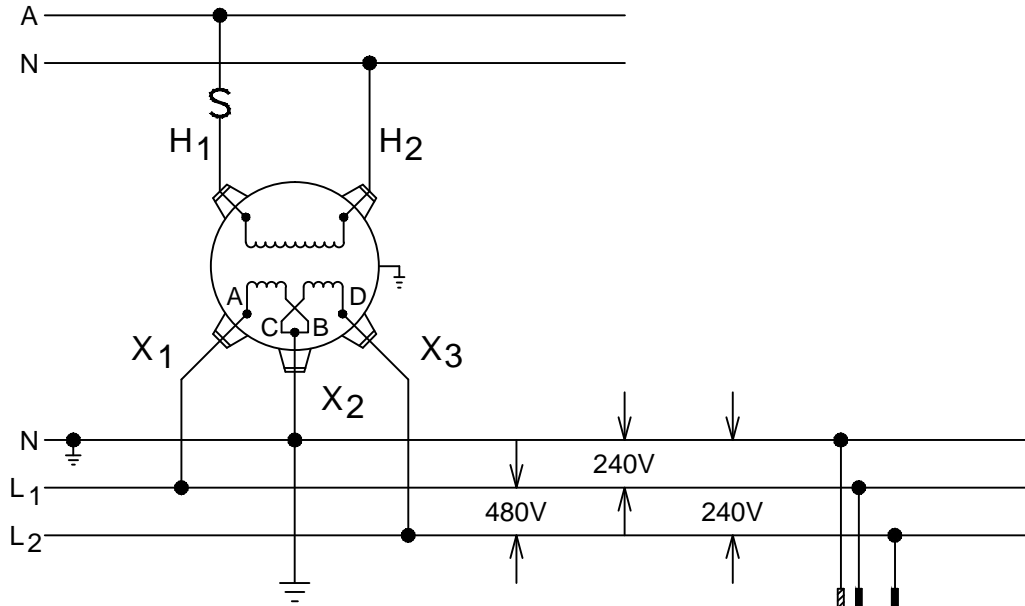

SEE NOTE 3

**3 WIRE METER
200 AMP - 240/480V
FORM 16S METER**

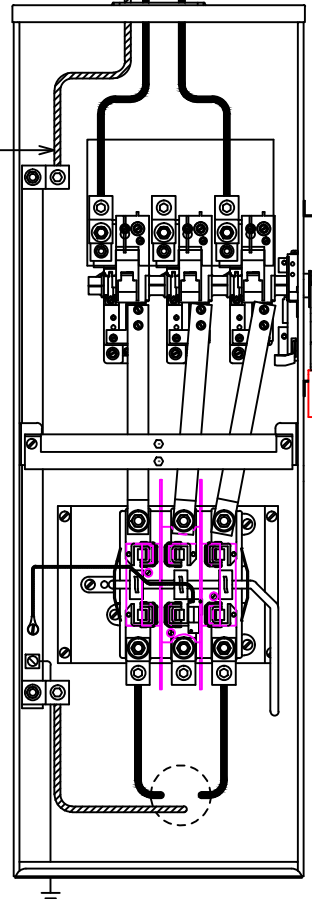

DISCONNECT SWITCH

NOTES:

1. SEE DRAWING 19.01-01 FOR GENERAL INFORMATION AND NOTES.
2. SEE DRAWING 19.03-03A FOR METER SOCKET DETAILS.
3. NEUTRAL MUST BE TERMINATED ON SOURCE SIDE.

**EFFECTIVE
DATE:
06-05-17**

**DISTRIBUTION CONSTRUCTION STANDARD
DOMINION ENERGY SOUTH CAROLINA, INC.**

SINGLE-PHASE 120/208V NETWORK 3W WYE METER (200 AMPS)

BY JAL

DATE 05-04-17

REV. 0

19.02-04A

FORMERLY DWG # MTR-3, S1

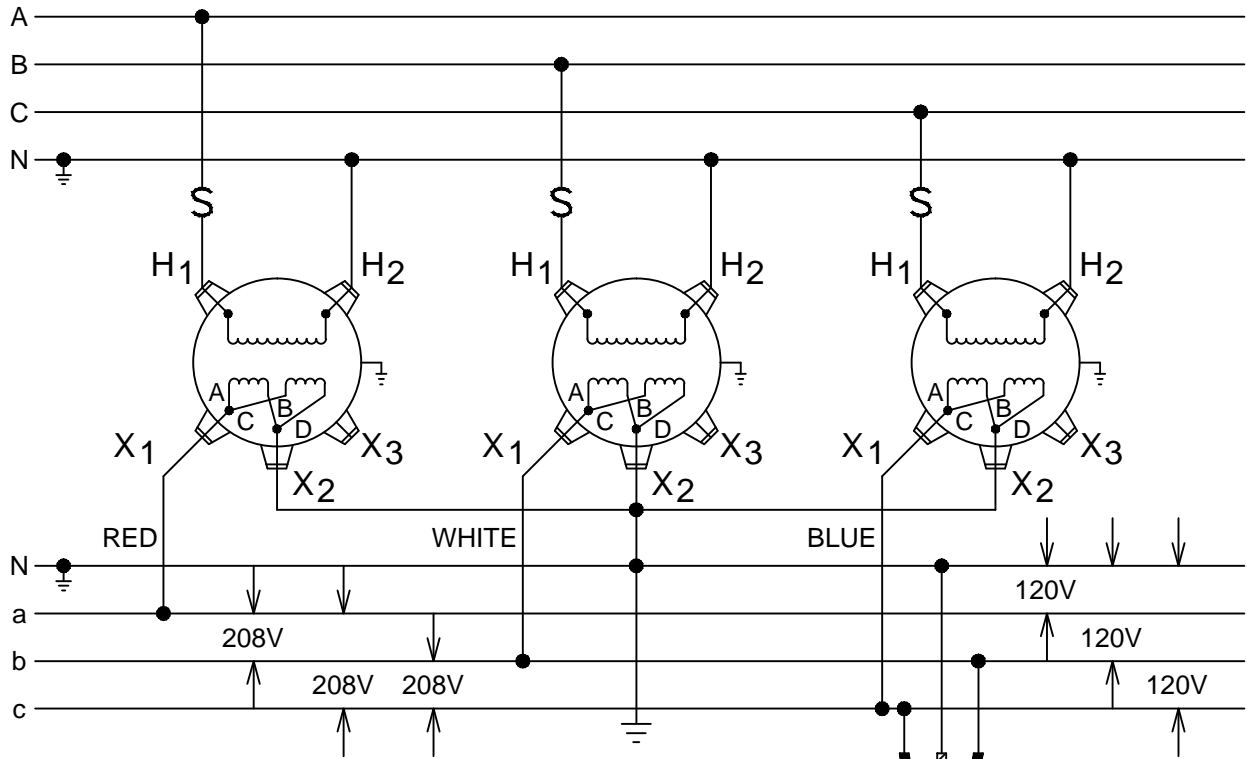

3 WIRE METER
200 AMP - 120/208V
FORM 12S / 25S METER

5TH LUG TERMINALS

STOCK CODE	TYPE
018.7780.1101	MILBANK (K5T)
018.7780.1112	LANDIS & GYR
018.7780.1123	DURHAM
018.7780.1125	MILBANK (5T8K2)

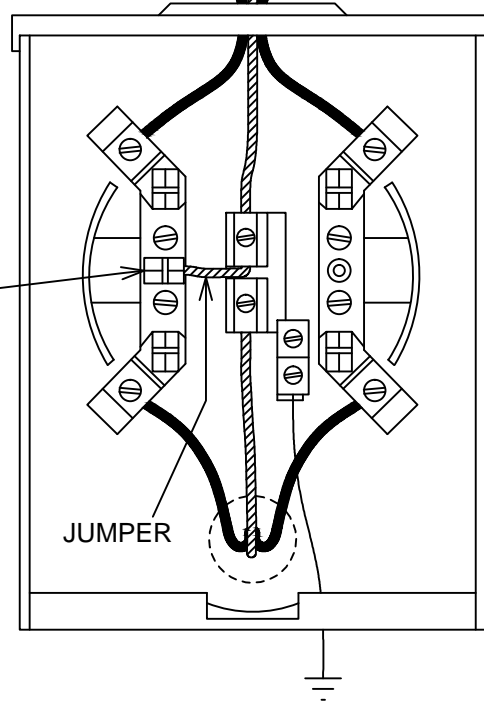

NOTE:

- SEE DRAWING 19.01-01 FOR GENERAL INFORMATION AND NOTES.

EFFECTIVE
DATE:
06-05-17

**DISTRIBUTION CONSTRUCTION STANDARD
DOMINION ENERGY SOUTH CAROLINA, INC.**

SINGLE-PHASE 120/208V NETWORK 3W WYE METER (201 - 600 AMPS)

BY JAL

DATE 05-04-17

REV. 0

19.02-04B

FORMERLY DWG # MTR-3, S2 & S3

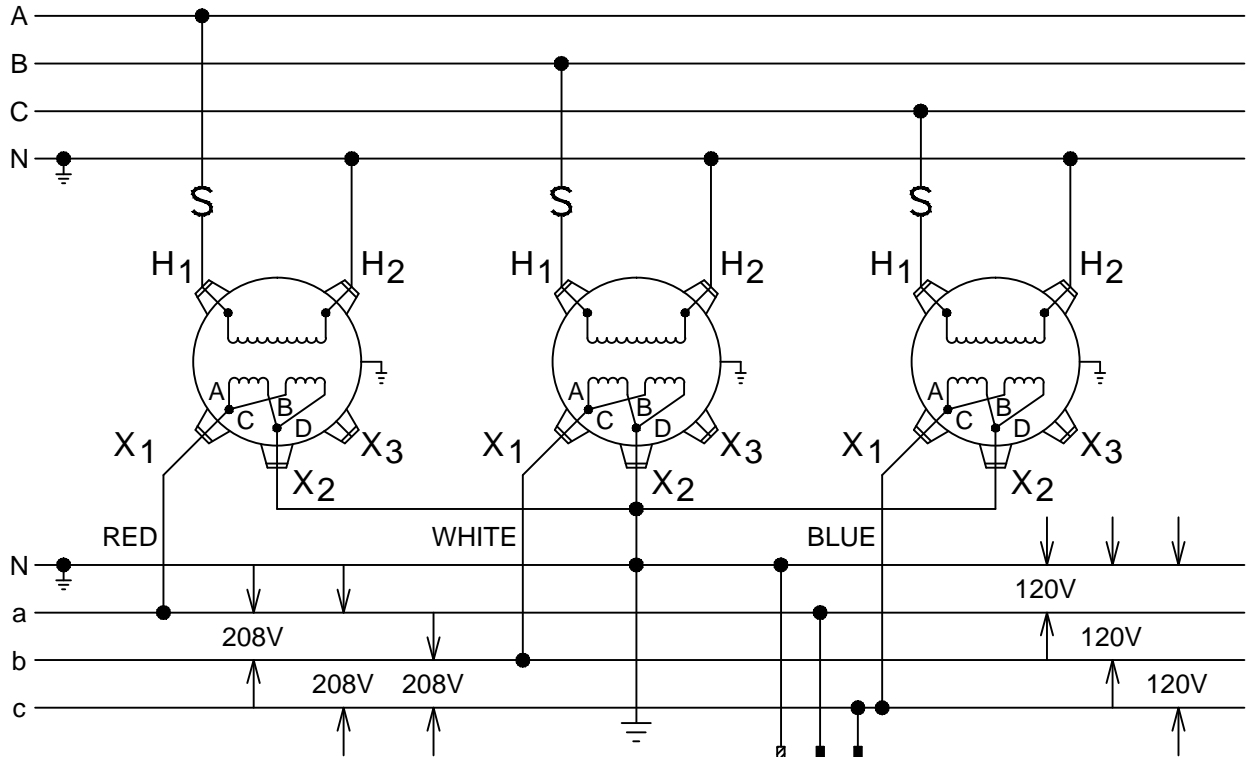

3 WIRE METER
201 - 600 AMPS - 120/208V
FORM 12K METER
K-5T SOCKET

DO NOT REMOVE
GROUND TERMINAL

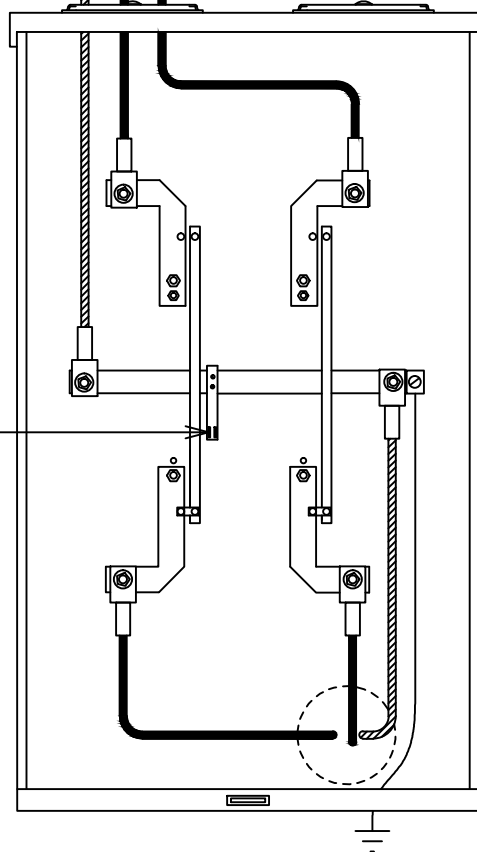

NOTE:

- SEE DRAWING 19.01-01 FOR GENERAL INFORMATION AND NOTES.

EFFECTIVE
DATE:
06-05-17

**DISTRIBUTION CONSTRUCTION STANDARD
DOMINION ENERGY SOUTH CAROLINA, INC.**

THREE-PHASE 120/208V 4W WYE (201 - 600 AMPS)

BY JAL
DATE 04-25-17
REV. 0

19.03-01B

FORMERLY DWG # MTR-5, S1 & S3

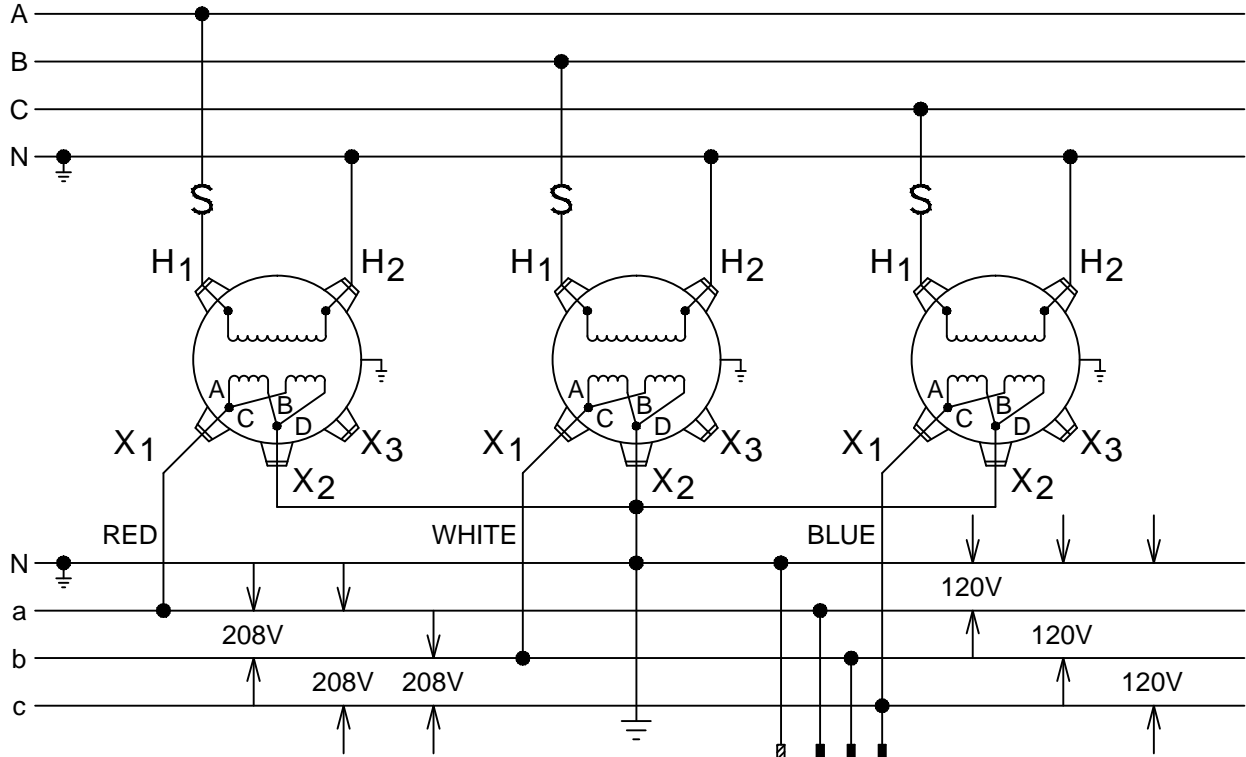

4 WIRE METER
201 - 600 AMPS - 120/208V
FORM 9K METER (KWH)
FORM 17K METER (KWH/KVA)
K-7T SOCKET

DO NOT REMOVE
GROUND TERMINAL

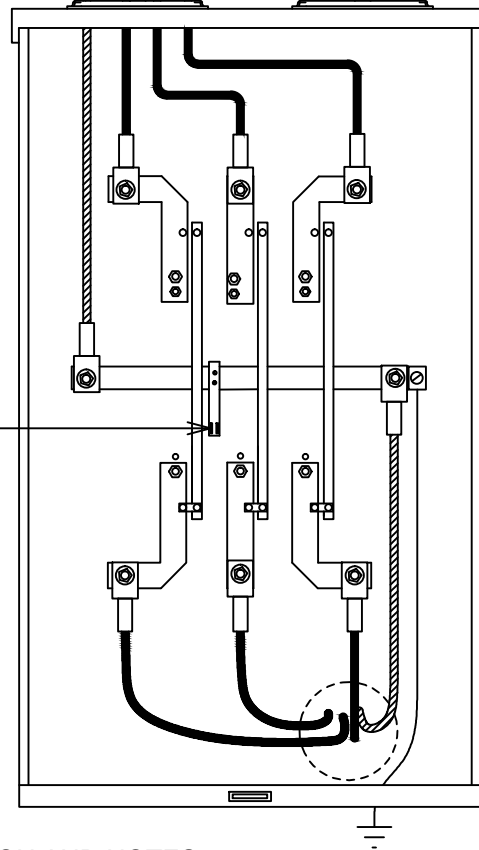

NOTE:

1. SEE DRAWING 19.01-01 FOR GENERAL INFORMATION AND NOTES.

EFFECTIVE
DATE:
06-05-17

**DISTRIBUTION CONSTRUCTION STANDARD
DOMINION ENERGY SOUTH CAROLINA, INC.**

THREE-PHASE 120/208V 4W WYE (201 - 600 AMPS)

BY JAL
DATE 04-26-17
REV. 0

19.03-01C

FORMERLY DWG # MTR-5, S2

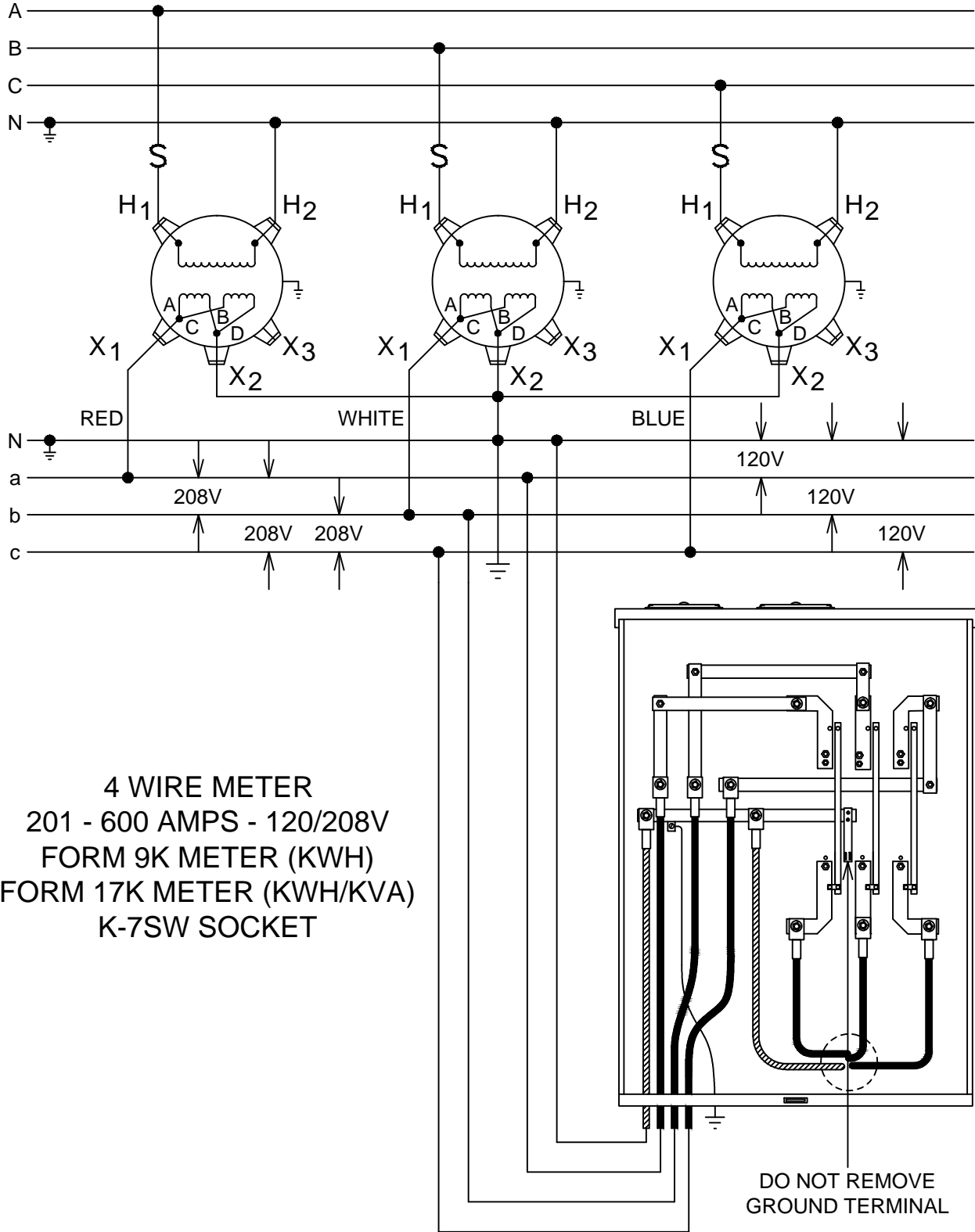

4 WIRE METER
201 - 600 AMPS - 120/208V
FORM 9K METER (KWH)
FORM 17K METER (KWH/KVA)
K-7SW SOCKET

NOTE:

1. SEE DRAWING 19.01-01 FOR GENERAL INFORMATION AND NOTES.

EFFECTIVE
DATE:
06-05-17

DISTRIBUTION CONSTRUCTION STANDARD
DOMINION ENERGY SOUTH CAROLINA, INC.

THREE-PHASE 120/240V 4W DELTA (200 AMPS)

BY JAL
DATE 04-26-17
REV. 0

19.03-02A

FORMERLY DWG # MTR-4, S1 & S2

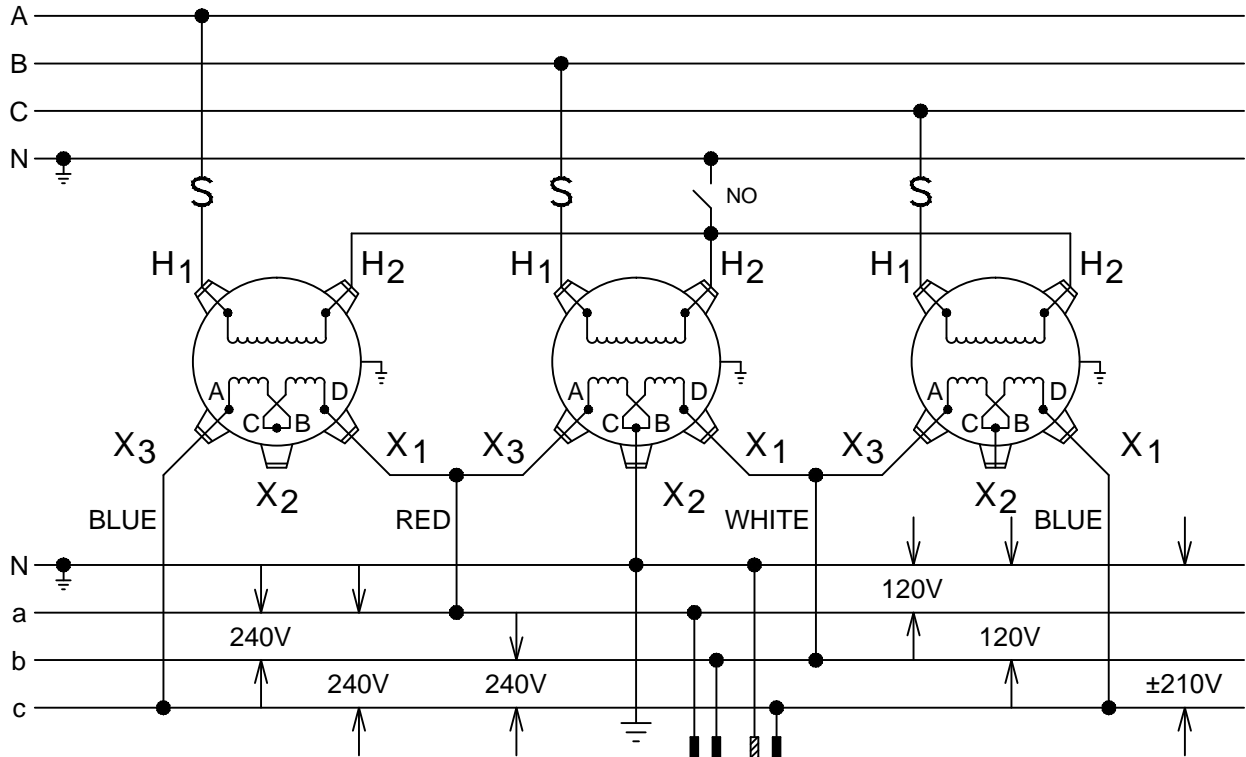

4 WIRE METER
200 AMP - 120/240V
FORM 16S METER

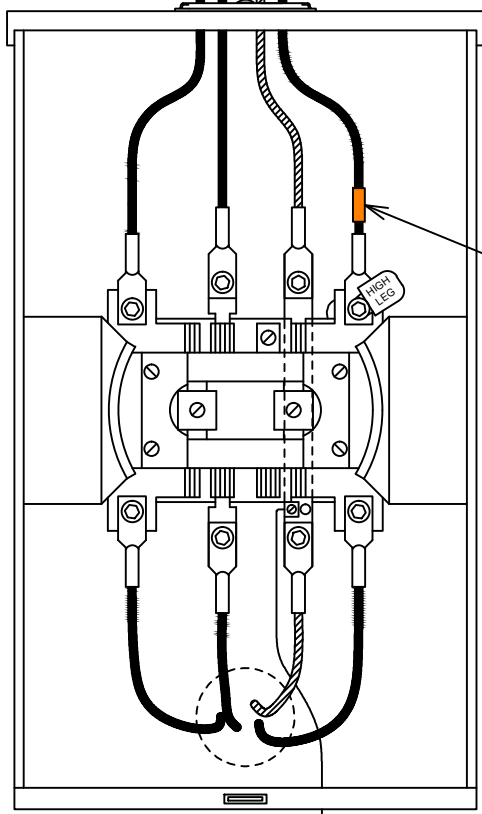

MARK HIGH
LEG WITH
ORANGE TAPE

NOTE:

1. SEE DRAWING 19.01-01 FOR GENERAL INFORMATION AND NOTES.

EFFECTIVE
DATE:
06-05-17

**DISTRIBUTION CONSTRUCTION STANDARD
DOMINION ENERGY SOUTH CAROLINA, INC.**

THREE-PHASE 120/240V 4W DELTA (201 - 600 AMPS)

BY JAL
DATE 04-26-17
REV. 0

19.03-02B

FORMERLY DWG # MTR-5, S1 & S4

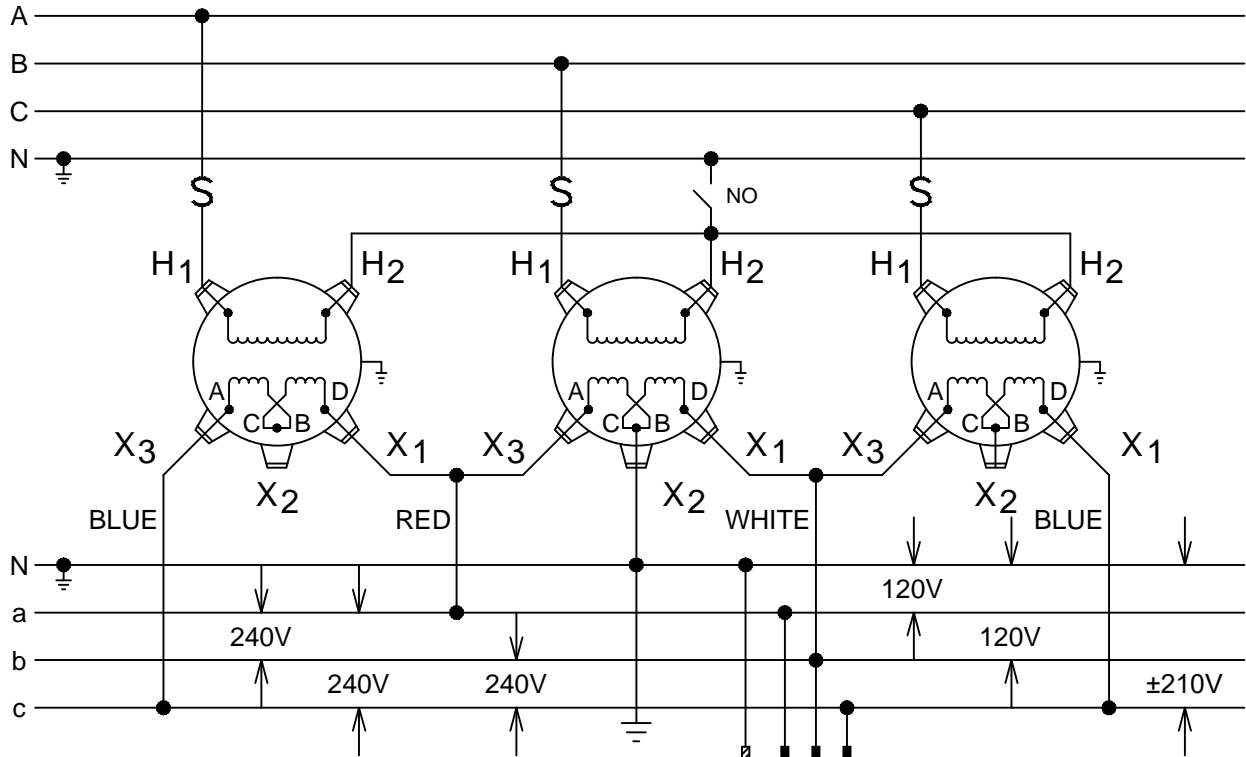

MARK HIGH LEG
WITH ORANGE TAPE

4 WIRE METER
201 - 600 AMPS - 120/240V
FORM 9K METER (KWH)
FORM 17K METER (KWH/KVA)
K-7T SOCKET

DO NOT REMOVE
GROUND TERMINAL

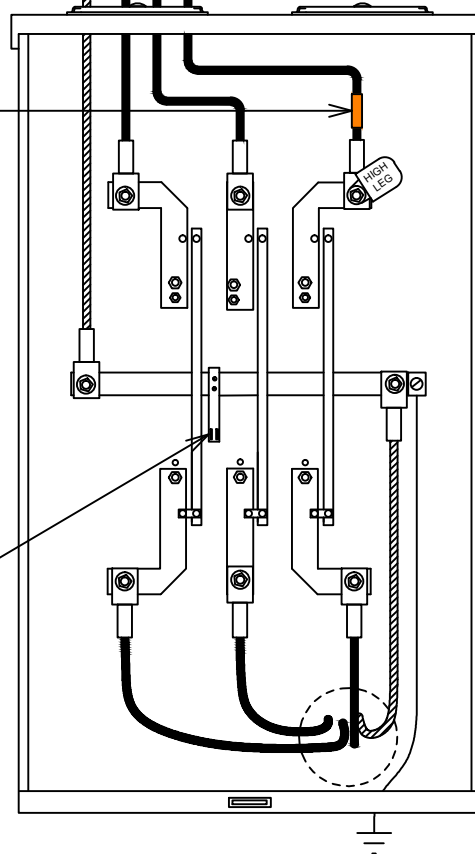

NOTE:

1. SEE DRAWING 19.01-01 FOR GENERAL INFORMATION AND NOTES.

EFFECTIVE
DATE:
06-05-17

**DISTRIBUTION CONSTRUCTION STANDARD
DOMINION ENERGY SOUTH CAROLINA, INC.**

THREE-PHASE 120/240V 4W DELTA (201 - 600 AMPS)

BY JAL

DATE 04-26-17

REV. 0

19.03-02C

FORMERLY DWG # MTR-5, S2

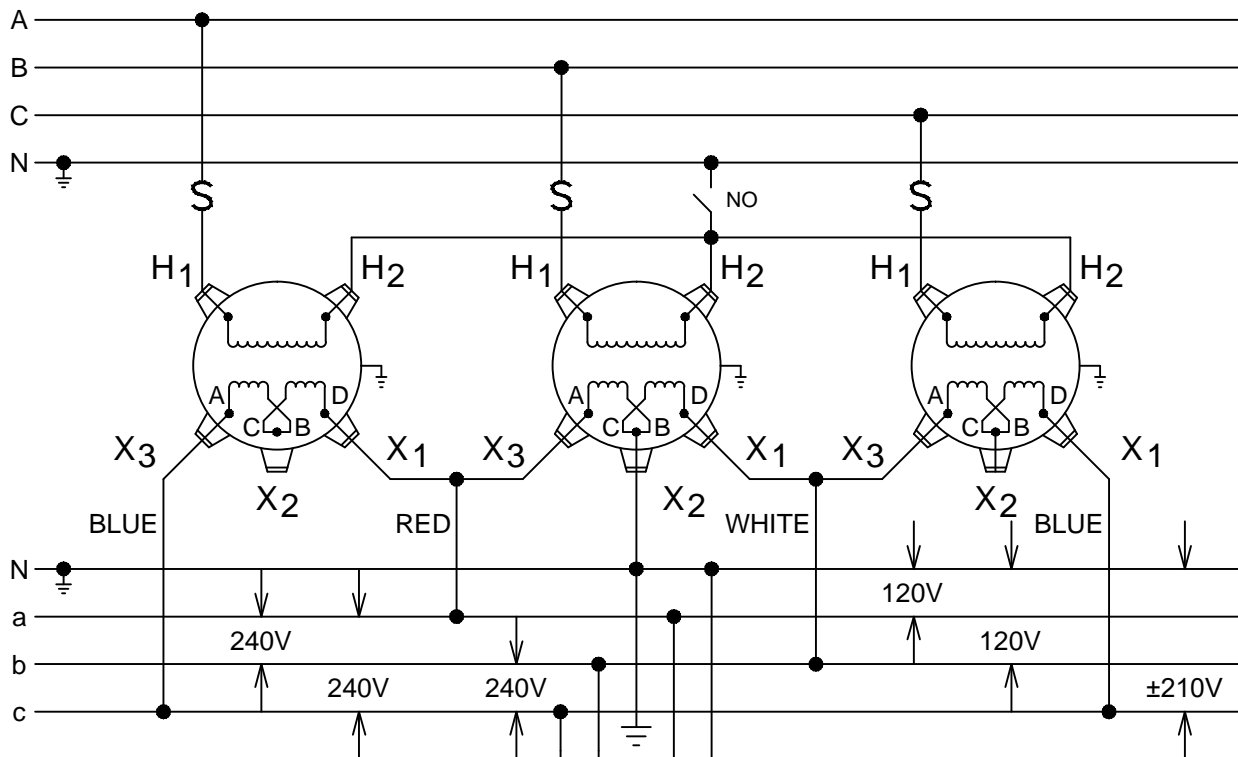

4 WIRE METER
201 - 600 AMPS - 120/240V
FORM 9K METER (KWH)
FORM 17K METER (KWH/KVA)
K-7SW SOCKET

MARK HIGH LEG
WITH ORANGE TAPE

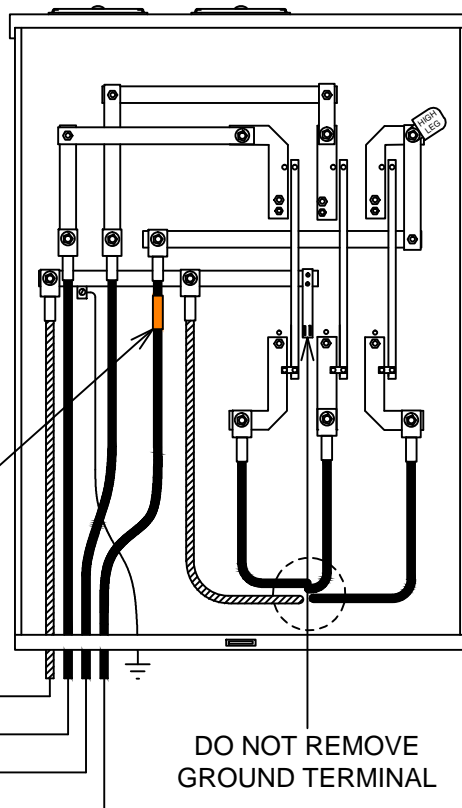

NOTE:

1. SEE DRAWING 19.01-01 FOR GENERAL INFORMATION AND NOTES.

EFFECTIVE
DATE:
06-05-17

DISTRIBUTION CONSTRUCTION STANDARD
DOMINION ENERGY SOUTH CAROLINA, INC.

THREE-PHASE 277/480V
4W WYE (200 AMPS)

BY JAL
DATE 03-20-19
REV. 1

19.03-03A

REV. 1 (03/20/19) - CHANGED SCE&G TO COMPANY

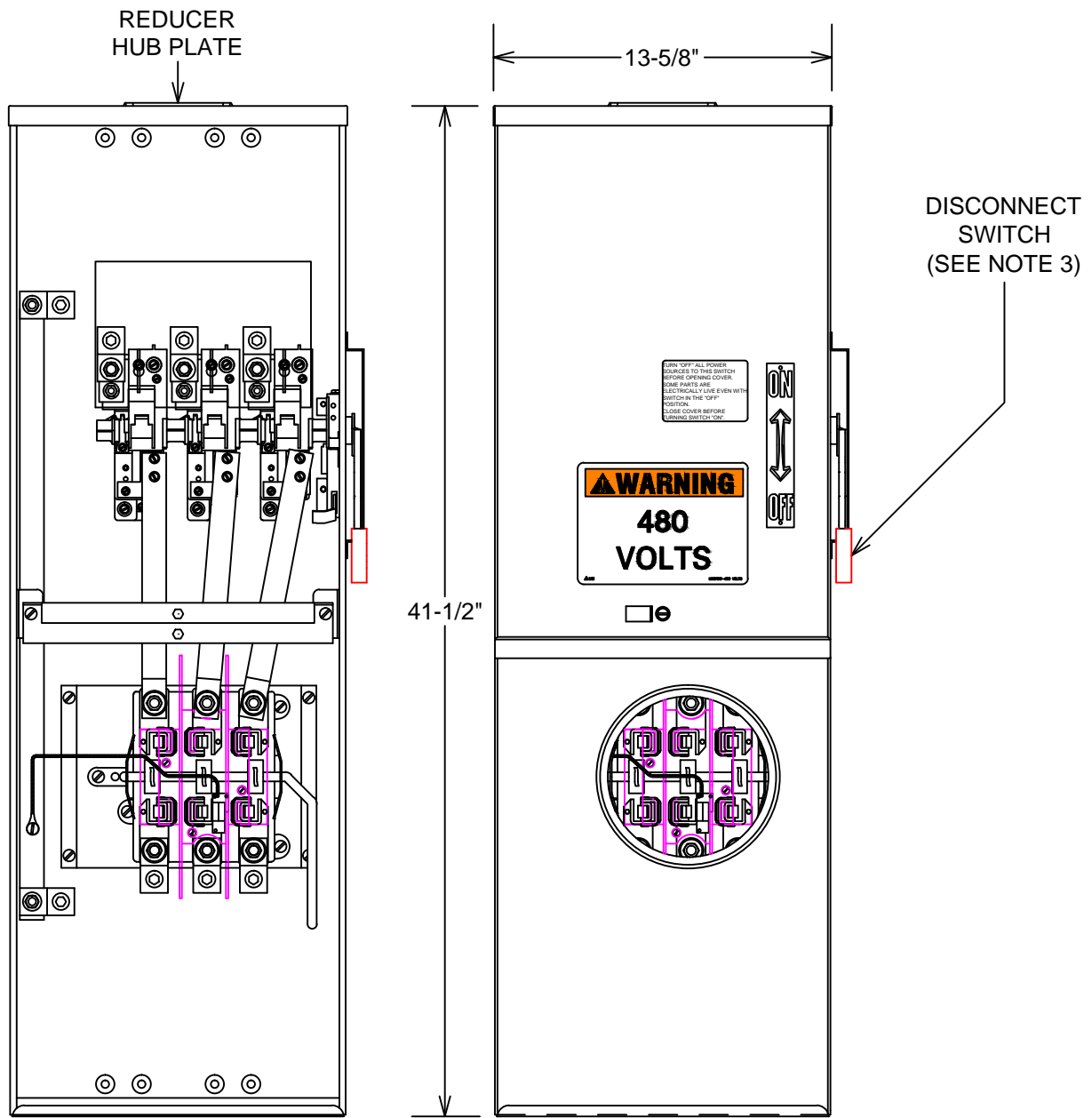

CU CODE: QSC277C2
STOCK CODE: 018.7740.6010

NOTES:

1. SEE DRAWING 19.01-01 FOR GENERAL INFORMATION AND NOTES.
2. THIS METER SOCKET IS SUPPLIED BY THE COMPANY AND INSTALLED BY THE CUSTOMER.
3. THE DISCONNECT SWITCH IS FOR COMPANY USE ONLY AND IS EQUIPPED WITH AN INTERLOCKING MECHANISM THAT PREVENTS THE METER FROM BEING REMOVED OR INSTALLED WHILE THE SOCKET IS ENERGIZED. THE DISCONNECT SWITCH SHALL BE LOCKED/SEALED OPEN OR CLOSED BY USE OF A COMPANY LOCK.

EFFECTIVE DATE:
04-29-19

DISTRIBUTION CONSTRUCTION STANDARD
DOMINION ENERGY SOUTH CAROLINA, INC.

THREE-PHASE 277/480V 4W WYE (200 AMPS)

BY JAL
DATE 04-26-17
REV. 0

19.03-03B

FORMERLY DWG # MTR-2, S4

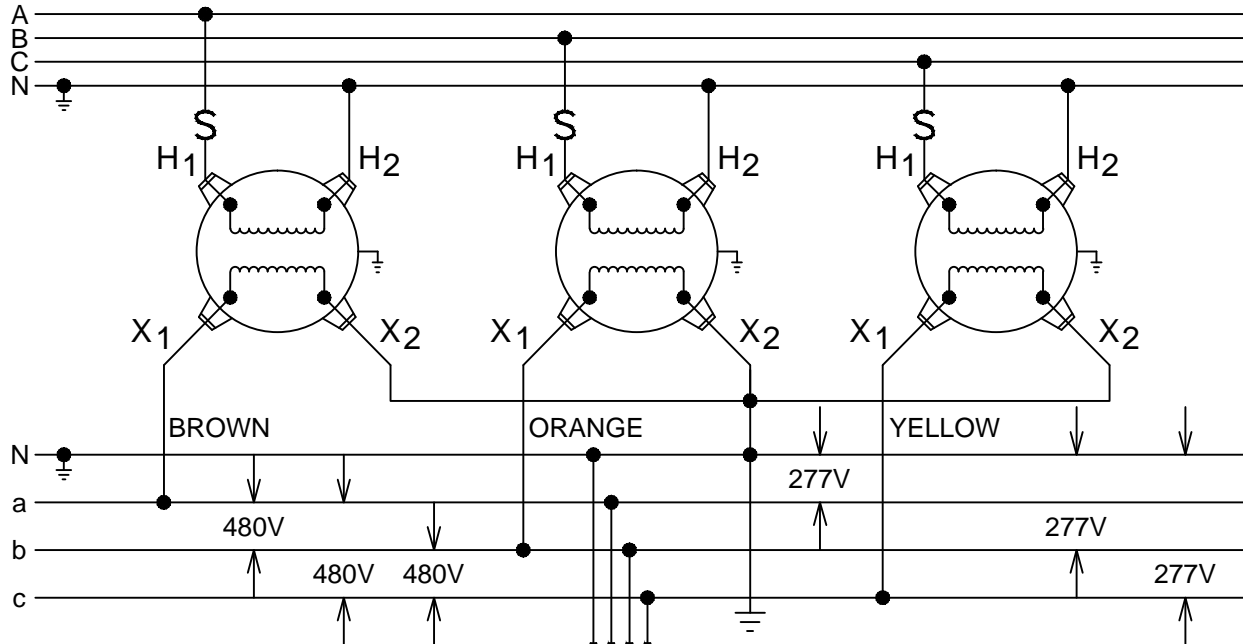

4 WIRE METER
200 AMP - 277/480V
FORM 16S METER

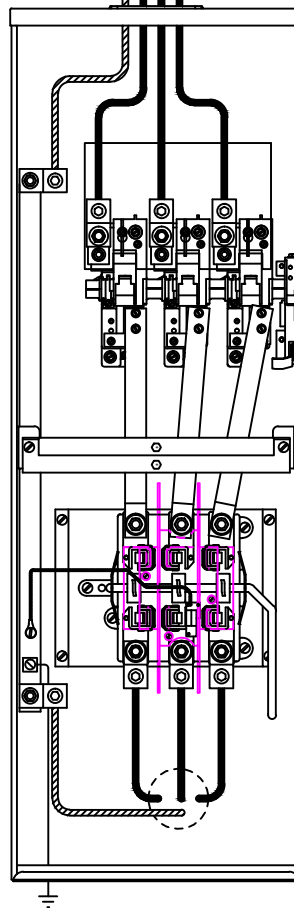

DISCONNECT SWITCH

NOTES:

1. SEE DRAWING 19.01-01 FOR GENERAL INFORMATION AND NOTES.
2. SEE DRAWING 19.03-03A FOR METER SOCKET DETAILS.

EFFECTIVE
DATE:
06-05-17

**DISTRIBUTION CONSTRUCTION STANDARD
DOMINION ENERGY SOUTH CAROLINA, INC.**

CT METERING ENCLOSURE

BY JAL

DATE 05-01-17

REV. 0

19.04-01

FORMERLY DWG # MTR-CT, S2 & S3

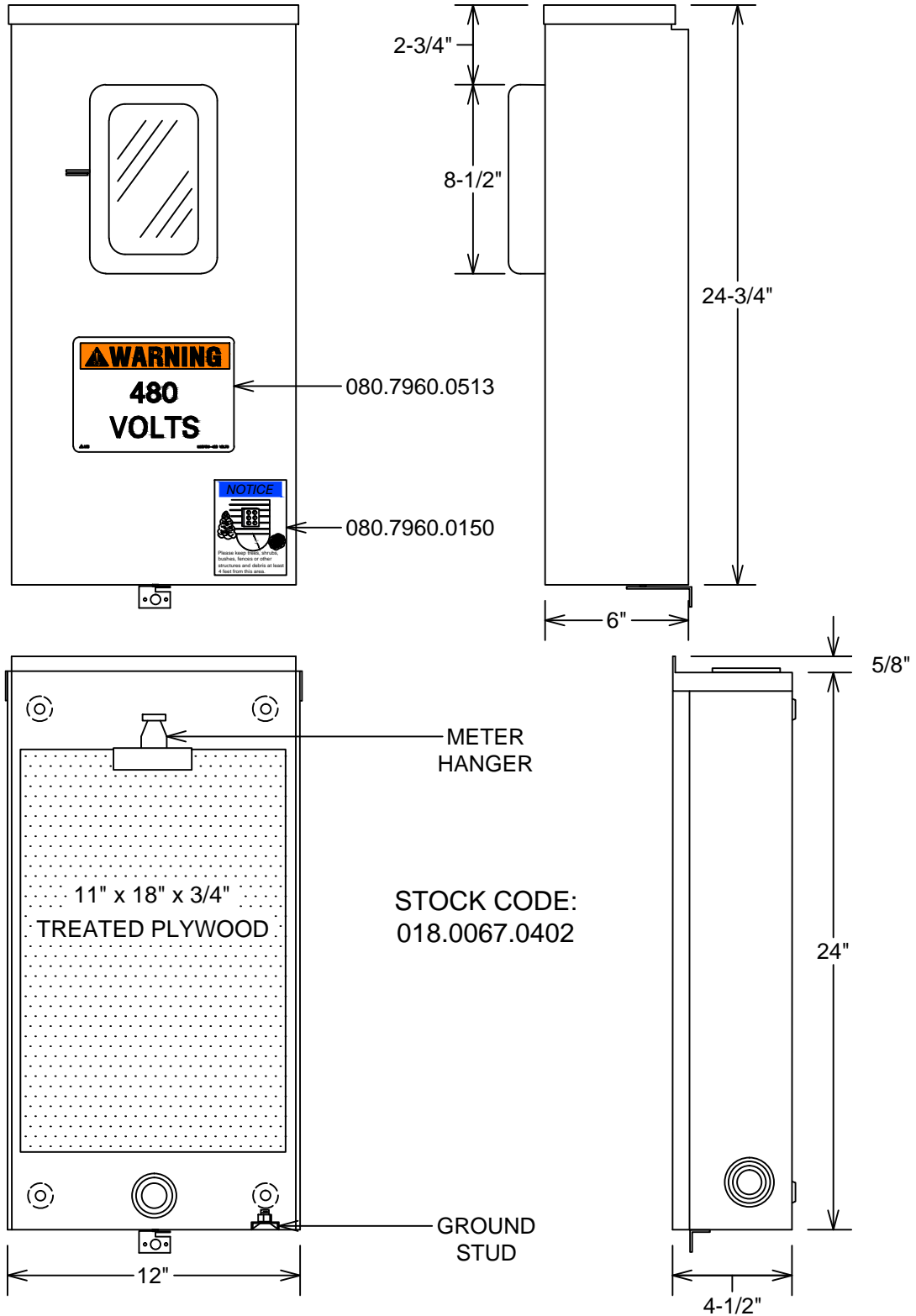

NOTE:

- 1. SEE DRAWING 19.01-01 FOR GENERAL INFORMATION AND NOTES.

EFFECTIVE DATE:
06-05-17

DISTRIBUTION CONSTRUCTION STANDARD
DOMINION ENERGY SOUTH CAROLINA, INC.

CT METERING - OVERHEAD MAST

BY JAL

DATE 03-20-19

REV. 1

19.04-02

REV. 1 (03/20/19) - CHANGED SCE&G TO COMPANY

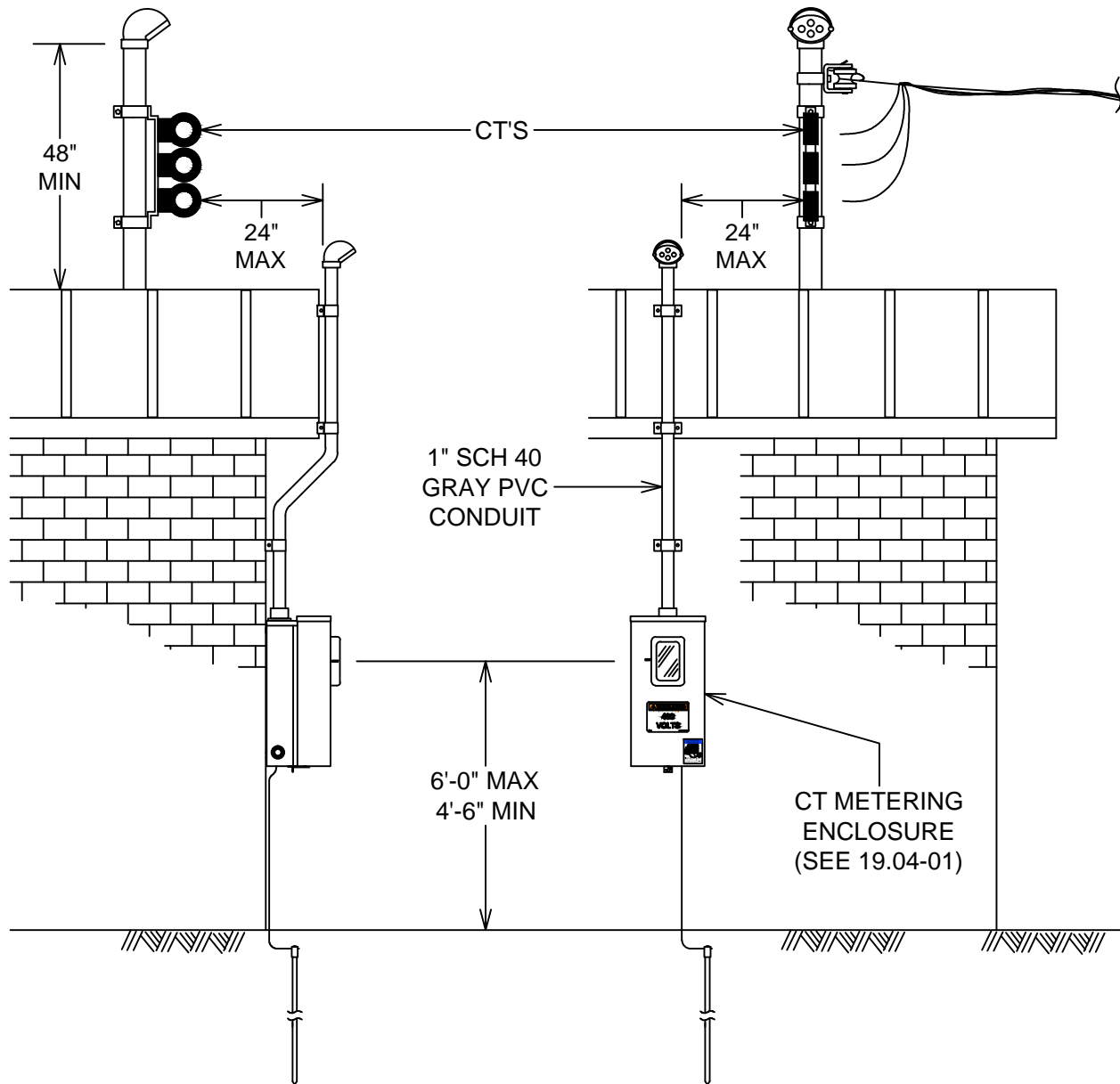

NOTES:

1. COMPANY WILL FURNISH CT METERING ENCLOSURE, CURRENT TRANSFORMERS (CT'S) AND CT MOUNTING BRACKET. CT METERING ENCLOSURE SHALL BE NO MORE THAN 50 FEET FROM CT'S.
2. CUSTOMER IS RESPONSIBLE FOR INSTALLING CT METERING ENCLOSURE, CONDUIT, CT'S, CT MOUNTING BRACKET AND GROUNDING.
3. METERING CONDUIT SHALL NOT BE ROUTED THRU BUILDING FACADE, GUTTER OR ANY OTHER STRUCTURE (CONDUIT MUST OFFSET AS SHOWN).

EFFECTIVE
DATE:
04-29-19

DISTRIBUTION CONSTRUCTION STANDARD
DOMINION ENERGY SOUTH CAROLINA, INC.

CT METERING - POLE MOUNT

BY JAL

DATE 03-20-19

REV. 1

19.04-03

REV. 1 (03/20/19) - CHANGED SCE&G TO COMPANY

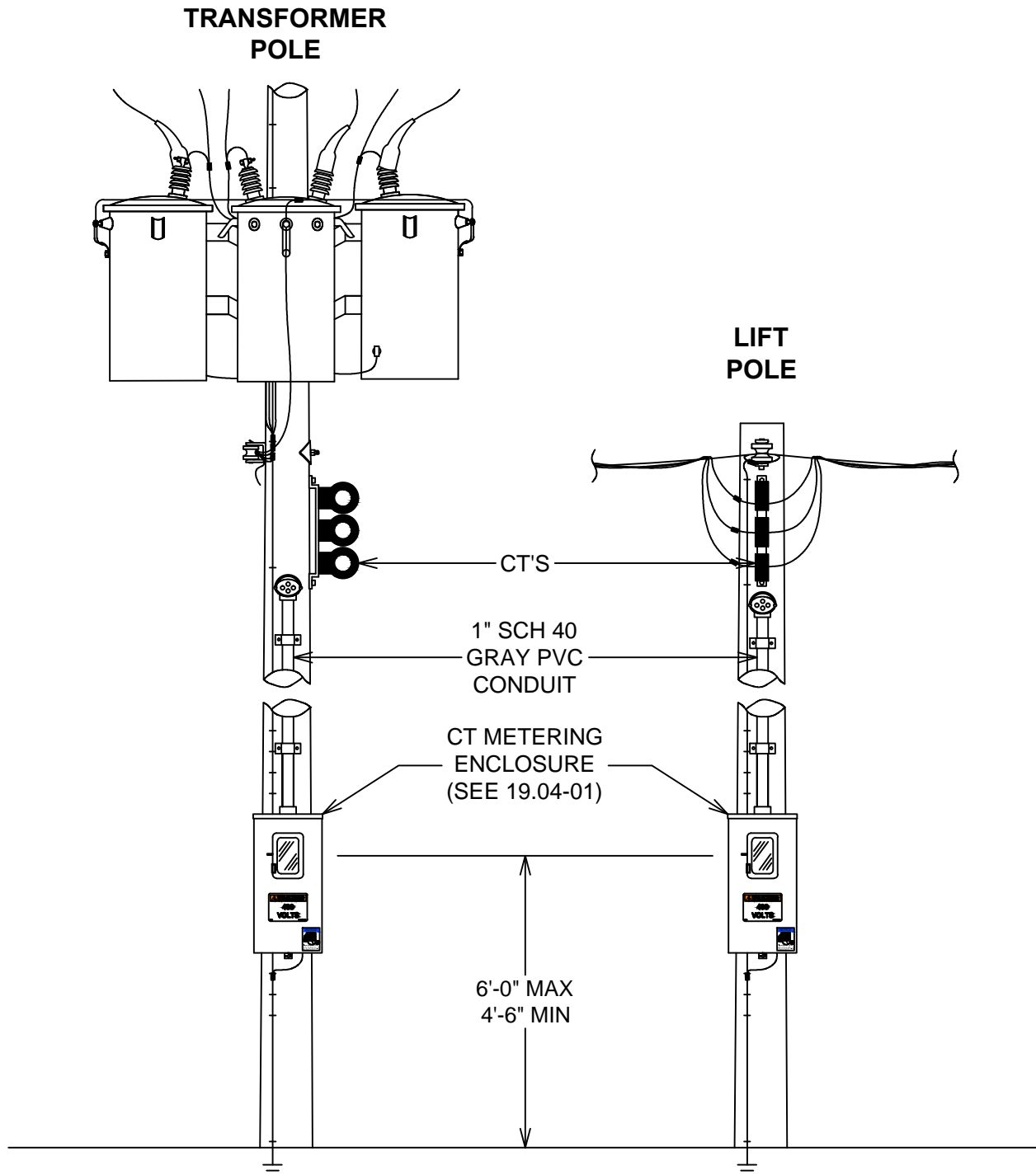

NOTES:

1. COMPANY WILL FURNISH AND INSTALL CT METERING ENCLOSURE, CURRENT TRANSFORMERS (CT'S), CT MOUNTING BRACKET AND GROUNDING. CT METERING ENCLOSURE SHALL BE NO MORE THAN 50 FEET FROM CT'S.
2. ALL SECONDARIES AND SERVICES SHALL MEET MINIMUM CLEARANCE REQUIREMENTS (SEE DRAWINGS 01.02-01, 01.03-01A AND 01.03-01B).

EFFECTIVE
DATE:
04-29-19

DISTRIBUTION CONSTRUCTION STANDARD
DOMINION ENERGY SOUTH CAROLINA, INC.

CT METERING - PAD MOUNT TRANSFORMER

BY JAL

DATE 03-20-19

REV. 1

19.04-04

REV. 1 (03/20/19) - CHANGED SCE&G TO COMPANY

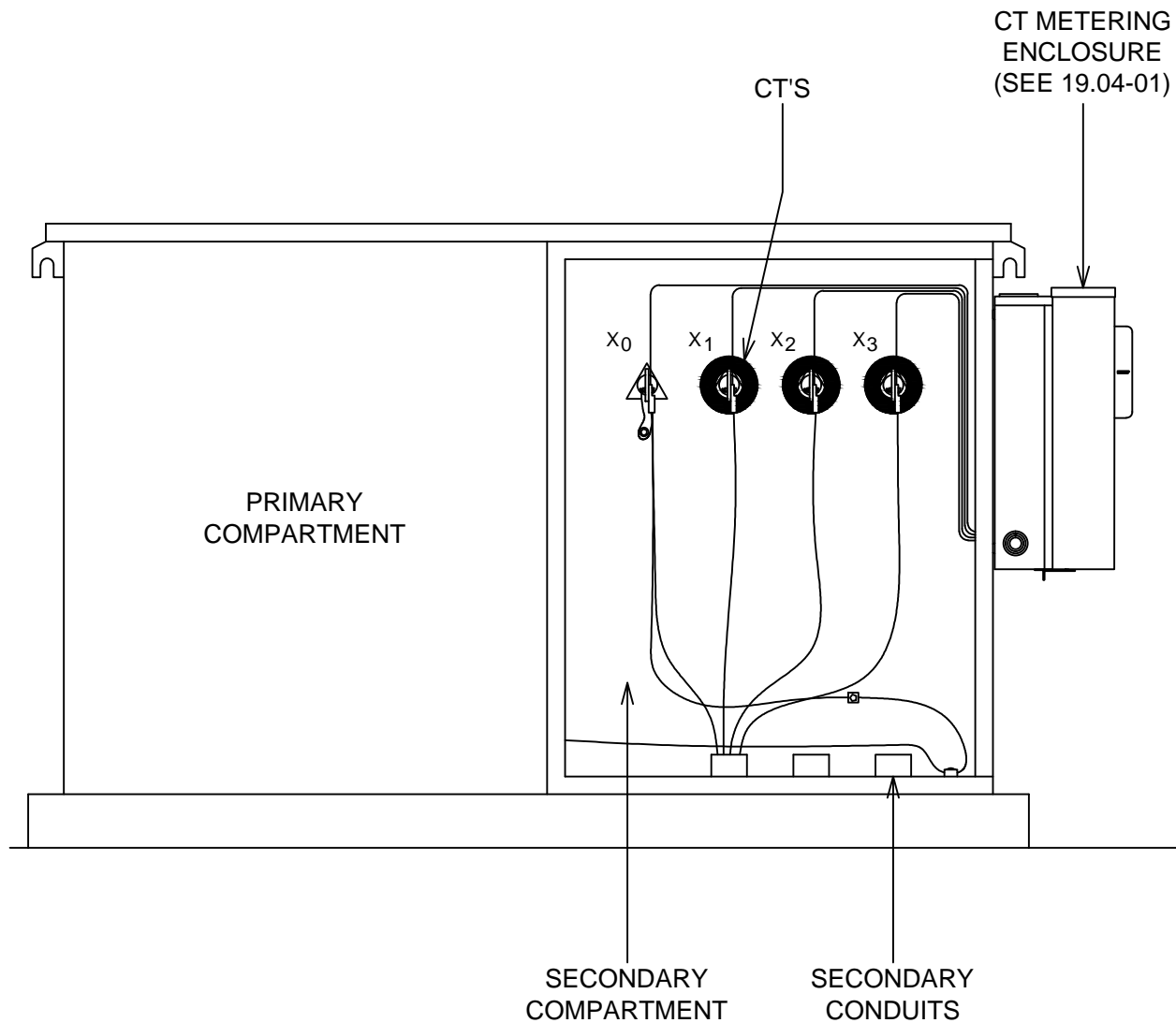

NOTE:

1. COMPANY WILL FURNISH AND INSTALL CT METERING ENCLOSURE, CURRENT TRANSFORMERS (CT'S), CT MOUNTING BRACKET AND GROUNDING. CT METERING ENCLOSURE SHALL BE NO MORE THAN 50 FEET FROM CT'S.

EFFECTIVE
DATE:
04-29-19

**DISTRIBUTION CONSTRUCTION STANDARD
DOMINION ENERGY SOUTH CAROLINA, INC.**

CUSTOMER PULSES FROM KWH METER

BY JAL

DATE 05-04-17

REV. 0

19.04-14A

FORMERLY DWG # CMTR-19

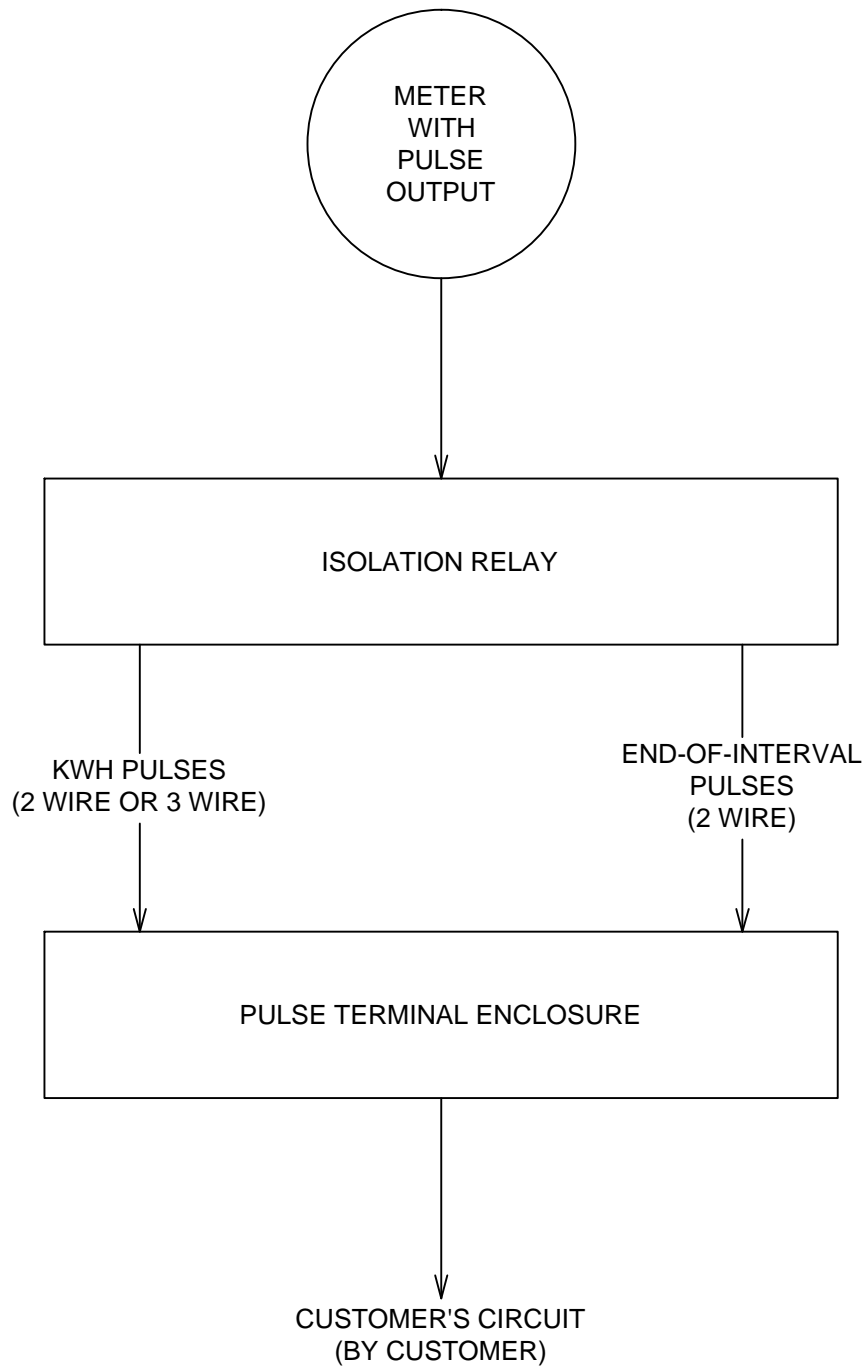

NOTES:

- 1. SEE DRAWING 19.04-14B FOR PULSE TERMINAL ENCLOSURE WIRING DETAIL.
- 2. SEE DRAWING 19.04-14C FOR PULSE TERMINAL ENCLOSURE MOUNTING OPTIONS.
- 3. CUSTOMER IS RESPONSIBLE FOR INSTALLING CONDUIT AND CONDUCTORS FROM THE PULSE TERMINAL ENCLOSURE TO THEIR EQUIPMENT.

EFFECTIVE DATE:
06-05-17

**DISTRIBUTION CONSTRUCTION STANDARD
DOMINION ENERGY SOUTH CAROLINA, INC.**

CUSTOMER PULSES WIRING DETAIL

BY JAL

DATE 05-03-17

REV. 0

19.04-14B

FORMERLY DWG # CMTR-21

PULSE TERMINAL ENCLOSURE (12" W X 14" H X 6" D)

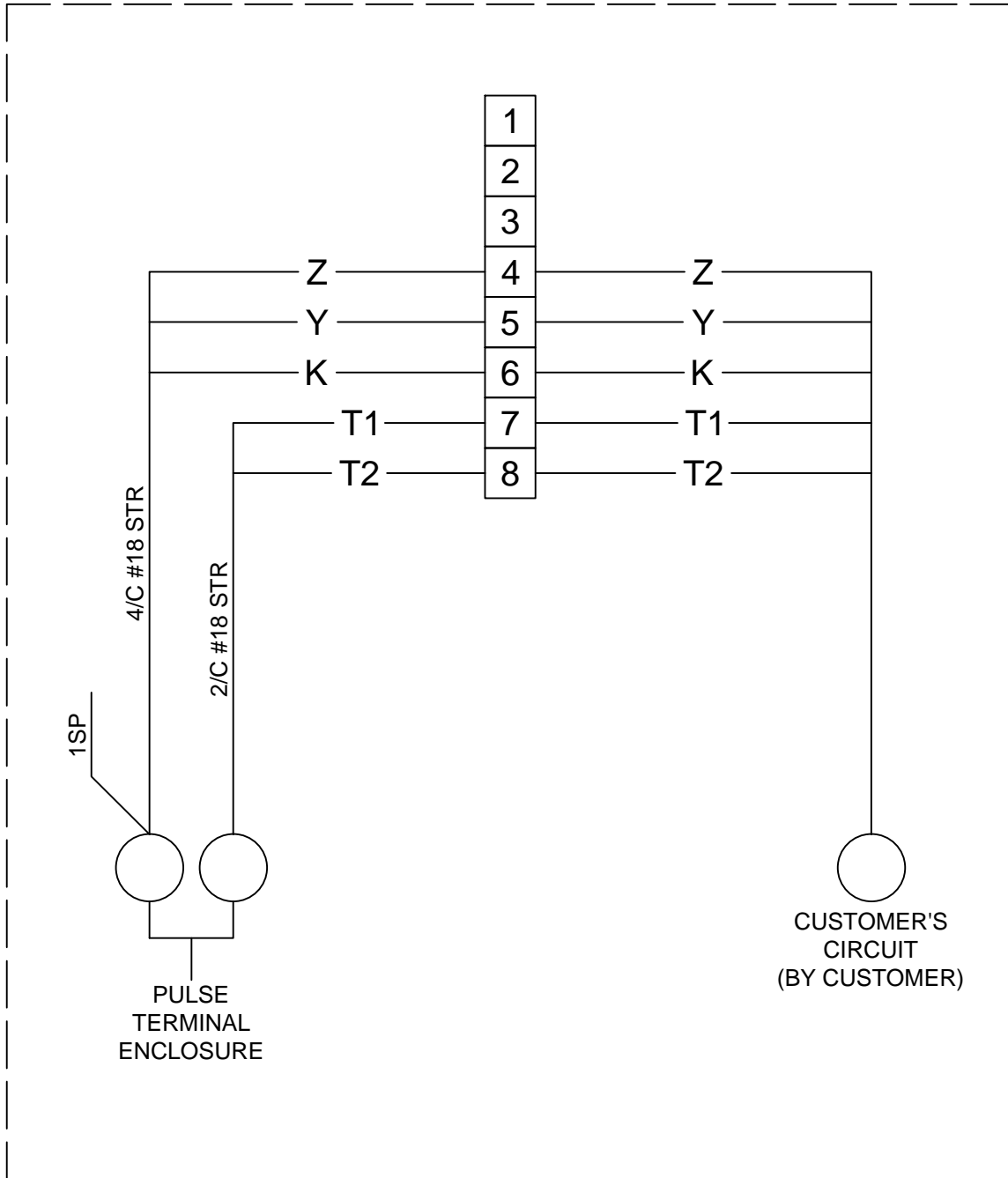

FOR 2 WIRE, USE K & Y

NOTE:

1. SEE DRAWING 19.04-14C FOR PULSE TERMINAL ENCLOSURE MOUNTING OPTIONS.

EFFECTIVE
DATE:
06-05-17

DISTRIBUTION CONSTRUCTION STANDARD
DOMINION ENERGY SOUTH CAROLINA, INC.

PULSE TERMINAL ENCLOSURE MOUNTING OPTIONS

BY JAL
DATE 05-04-17
REV. 0

19.04-14C

WALL MOUNT (OH SVC)

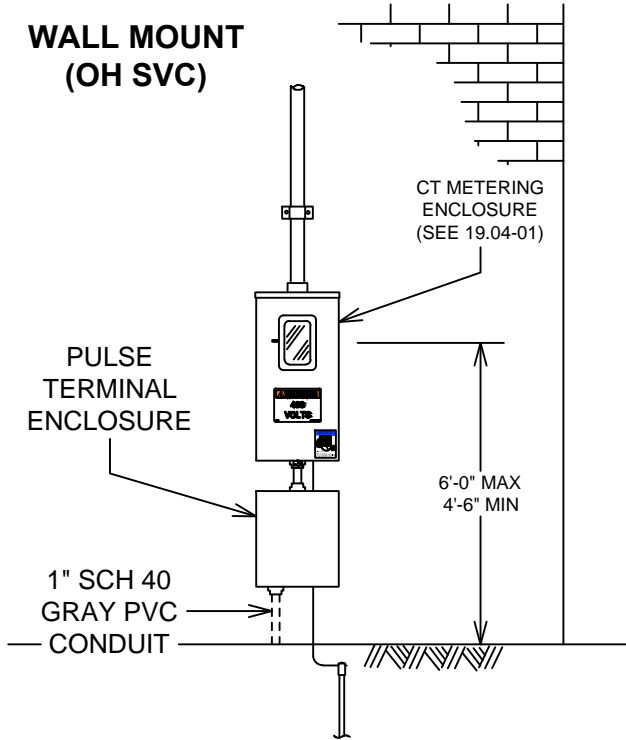

POLE MOUNT

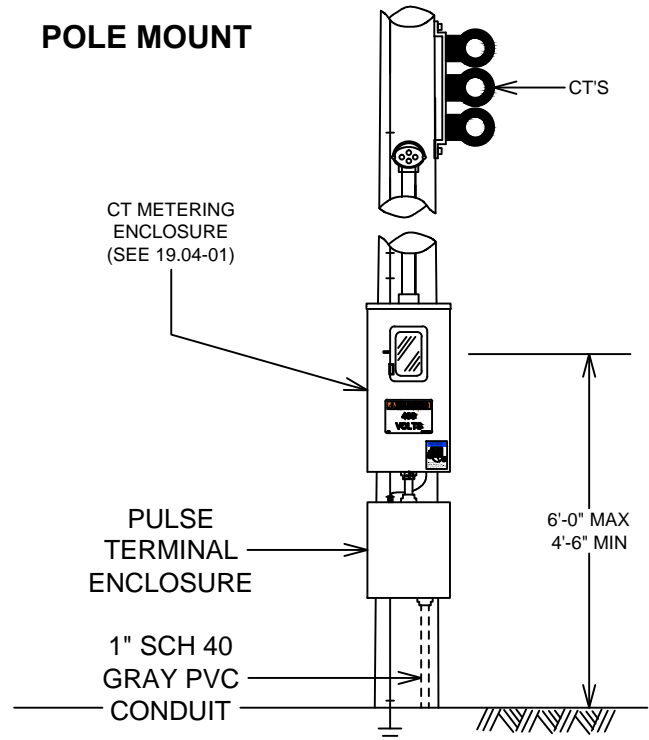

PAD MOUNT

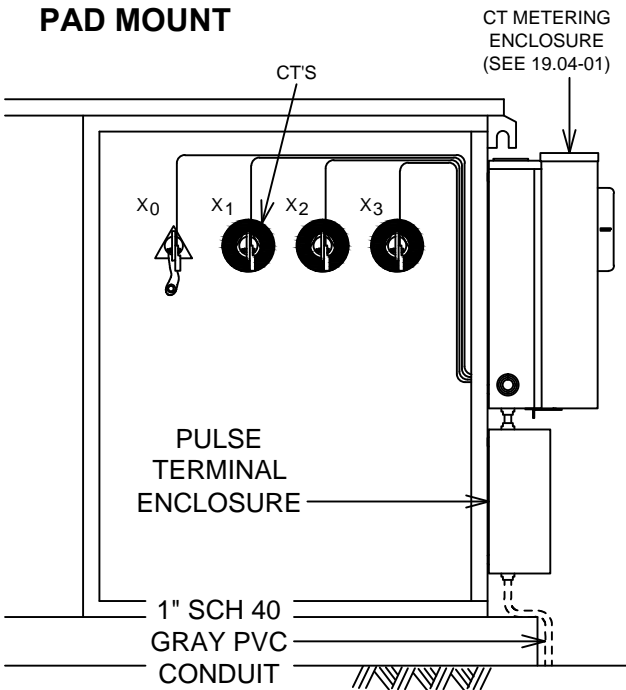

WALL MOUNT (UG SVC)

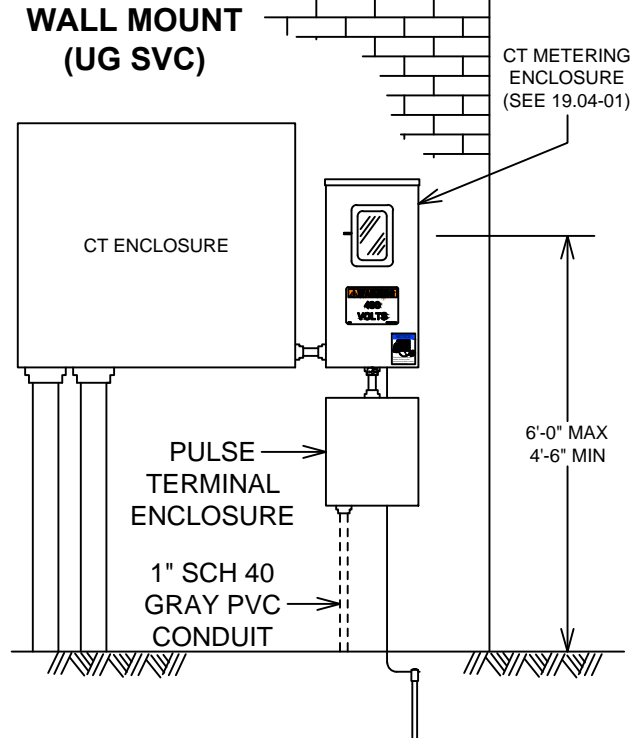

NOTES:

1. CUSTOMER WILL TAKE PULSES AT PULSE TERMINAL ENCLOSURE (SEE DRAWING 19.04-14A).
2. SEE DRAWING 19.04-14B FOR PULSE TERMINAL ENCLOSURE WIRING DETAIL.

EFFECTIVE
DATE:
06-05-17

DISTRIBUTION CONSTRUCTION STANDARD
DOMINION ENERGY SOUTH CAROLINA, INC.

OVERHEAD PRIMARY METERING

BY JAL
 DATE 11-12-18
 REV. 1

19.05-01

REV. 1 (11/12/18) - CHANGED SPACING FOR CLUSTER MOUNT & CLUSTER MOUNT STOCK CODE; SPECIFIED TRIM WIRE SIZE

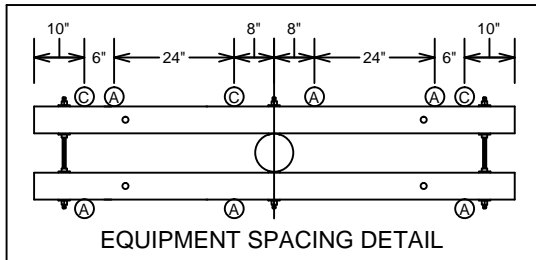
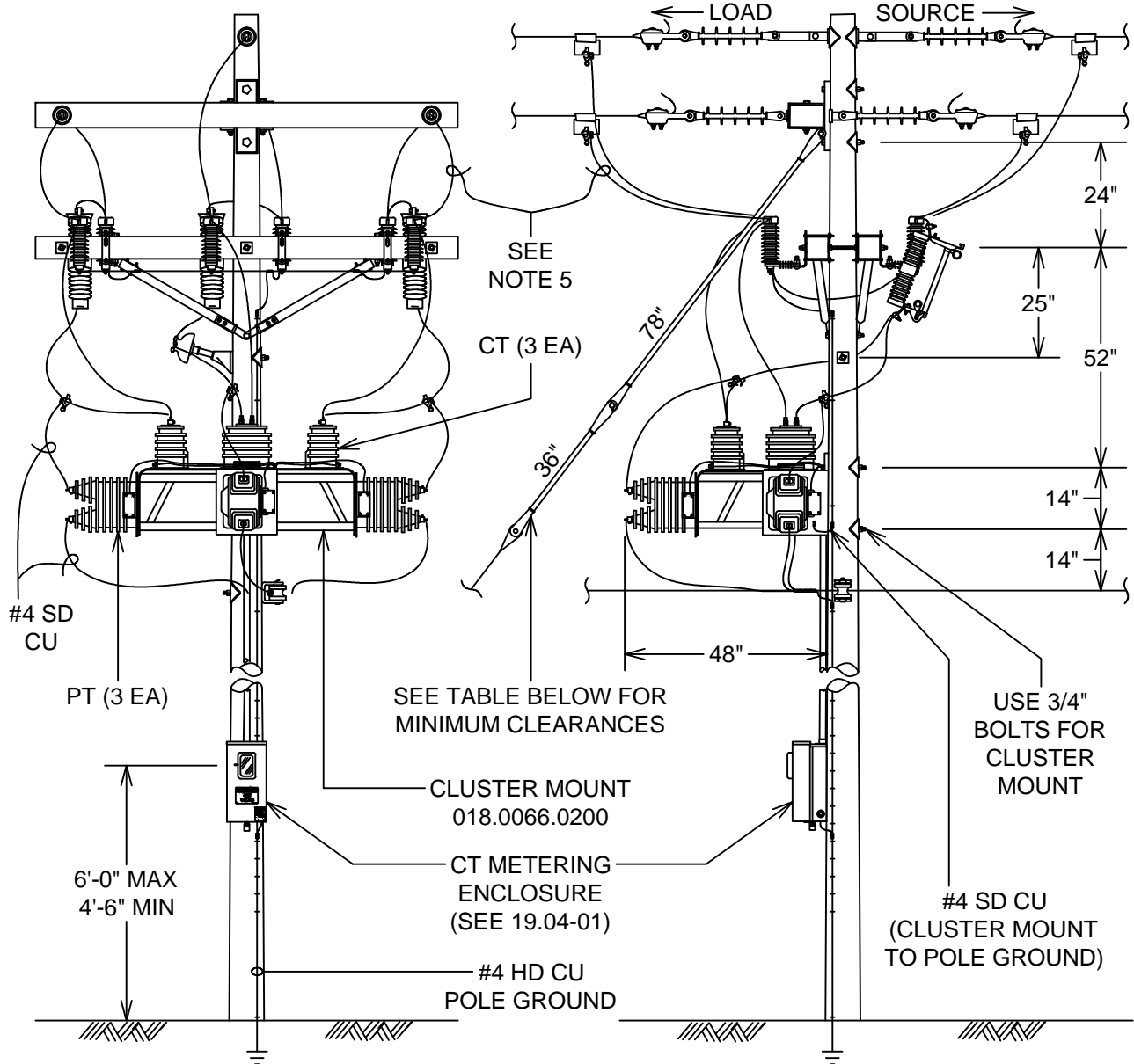

MINIMUM CLEARANCE DISTANCES		
VOLTAGE (ϕ TO ϕ)	ϕ TO ϕ	ϕ TO GROUND
4.16 KV	9"	9"
8.32 KV	9"	9"
12.47 KV	15"	12"
13.8 KV	15"	12"
23.9 KV	24"	18"

NOTES:

1. SEE DRAWINGS 04.01-01 AND 19.01-01 FOR GENERAL INFORMATION AND NOTES.
2. SEE SECTION 8 FOR GROUNDING DETAILS.
3. VERIFY AND MAINTAIN PROPER CLEARANCE BETWEEN CONDUCTORS, GROUNDS AND GUYS.
4. CONTACT DISTRIBUTION PLANNING FOR FUSE SIZE.
5. CT TRIM WIRE MUST MATCH THE AMPACITY OF THE PRIMARY CONDUCTOR.

EFFECTIVE DATE:
 02-15-19

DISTRIBUTION CONSTRUCTION STANDARD
DOMINION ENERGY SOUTH CAROLINA, INC.

CUSTOMER GENERATION METERING CONFIGURATIONS

BY JAL

DATE 04-10-19

REV. 1

19.06-01

REV. 1 (04/10/19) - CHANGED SCE&G TO COMPANY; RENAMED CONFIGURATION #2 "OFFSET / SELL" (FORMERLY "NET METERING")

CONFIGURATION #1 - OFFSET ONLY METHOD

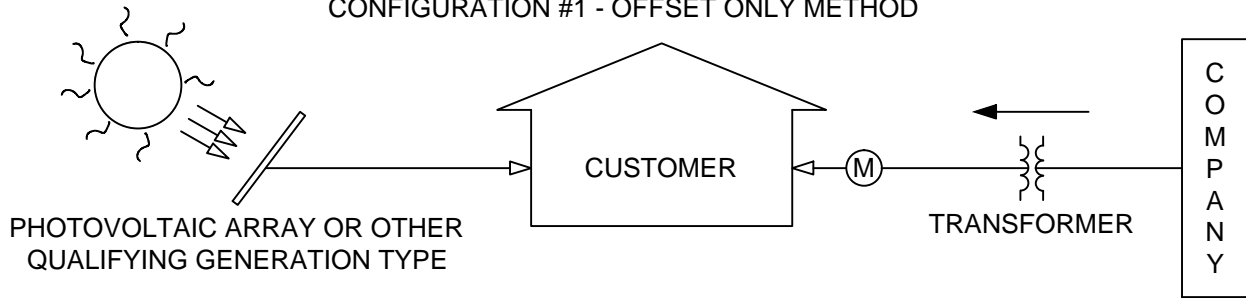

GENERAL GUIDELINES:

- CUSTOMER OFFSETS ENERGY REQUIREMENTS WITH ON-SITE GENERATION
- CUSTOMER PURCHASES ENERGY FROM UTILITY AT APPLICABLE RATE
- CUSTOMER DOES NOT RECEIVE CREDIT FOR ENERGY THAT MAY BE DELIVERED TO UTILITY

CONFIGURATION #2 - OFFSET / SELL

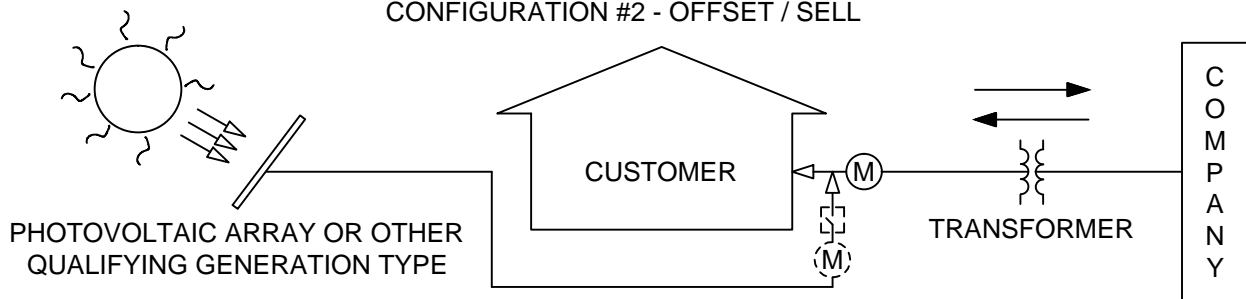

GENERAL GUIDELINES:

- GENERATION METER MAY BE REQUIRED FOR CERTAIN BILLING PROGRAMS
- CUSTOMER OFFSETS ENERGY REQUIREMENTS WITH ON-SITE GENERATION
- CUSTOMER PURCHASES ENERGY FROM UTILITY AT APPLICABLE RATE
- CUSTOMER COMPENSATED FOR EXCESS ENERGY SENT BACK TO UTILITY AT APPLICABLE RATE
- REFER TO DRAWING 19.06-02 FOR WIRING DIAGRAM AND METER BASE CONFIGURATION

CONFIGURATION #4 - BUY ALL / SELL ALL

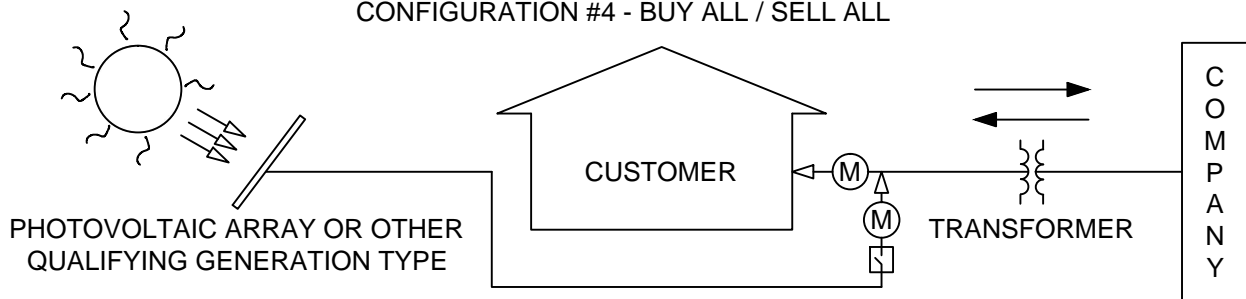

GENERAL GUIDELINES:

- DUAL METERS REQUIRED
- CUSTOMER PURCHASES ALL ENERGY FROM UTILITY AT APPLICABLE RATE
- CUSTOMER SELLS ALL ENERGY TO UTILITY ACCORDING TO APPLICABLE RATE
- REFER TO DRAWING 19.06-03 FOR WIRING DIAGRAM AND METER BASE CONFIGURATION

NOTES:

1. CUSTOMER EQUIPMENT MUST COMPLY WITH UTILITY SPECIFIED SAFETY REQUIREMENTS, INCLUDING UL AND IEEE STANDARDS.
2. CUSTOMER ELECTRICAL MODIFICATIONS ARE SUBJECT TO LOCAL INSPECTION REQUIREMENTS.

EFFECTIVE
DATE:
04-29-19

DISTRIBUTION CONSTRUCTION STANDARD
DOMINION ENERGY SOUTH CAROLINA, INC.

OFFSET / SELL WIRING DIAGRAM

BY JAL

DATE 04-10-19

REV. 1

19.06-02

OFFSET / SELL (CONFIGURATION #2)

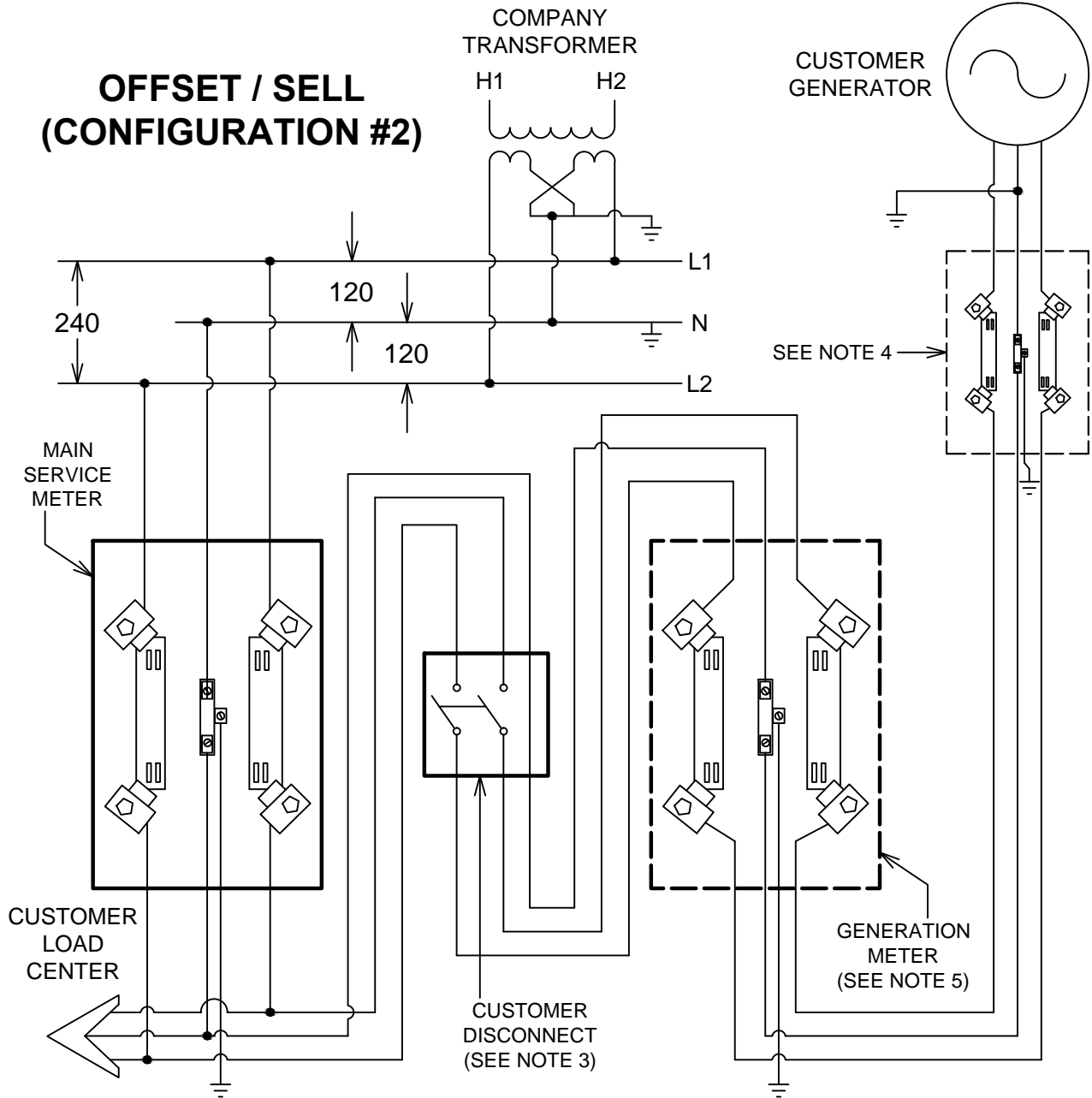

NOTES:

1. CUSTOMER GENERATOR CAN BE SOLAR, WIND OR OTHER QUALIFYING SYSTEM.
2. ALL EQUIPMENT MUST BE UL APPROVED, MEET IEEE STANDARDS AND COMPANY SAFETY REQUIREMENTS. INSTALLATION MUST MEET COMPANY, NEC, AND LOCAL CODE REQUIREMENTS.
3. MAIN SERVICE METER SOCKET AND CUSTOMER DISCONNECT MUST BE MARKED WITH PERMANENT LABELS (SUPPLIED BY COMPANY). STOCK CODE 080.7960.0380 (WARNING LABEL); STOCK CODE 080.7960.0377 (OFFSET / SELL LABEL).
4. IF REQUIRED, A NON-UTILITY METER SOCKET MAY BE INSTALLED BETWEEN THE GENERATOR AND THE MAIN SERVICE METER SOCKET. THE LOCATION OF THE NON-UTILITY METER SOCKET SHALL BE DETERMINED BY A COMPANY REPRESENTATIVE (THE PREFERRED LOCATION IS NOT ADJACENT TO THE MAIN SERVICE METER).
5. GENERATION METER ONLY REQUIRED FOR NET METERING.

REV. 1 (04/10/19) - CHANGED DWG TITLE; RENAMED CONFIGURATION #2 "OFFSET / SELL" (FORMERLY "NET METERING"); UPDATED NOTES

EFFECTIVE DATE:
04-29-19

**DISTRIBUTION CONSTRUCTION STANDARD
DOMINION ENERGY SOUTH CAROLINA, INC.**

BUY ALL / SELL ALL WIRING DIAGRAM

BY JAL

DATE 03-20-19

REV. 1

19.06-03

REV. 1 (03/20/19) - CHANGED SCE&G TO COMPANY; UPDATED NOTES

BUY ALL / SELL ALL (CONFIGURATION #4)

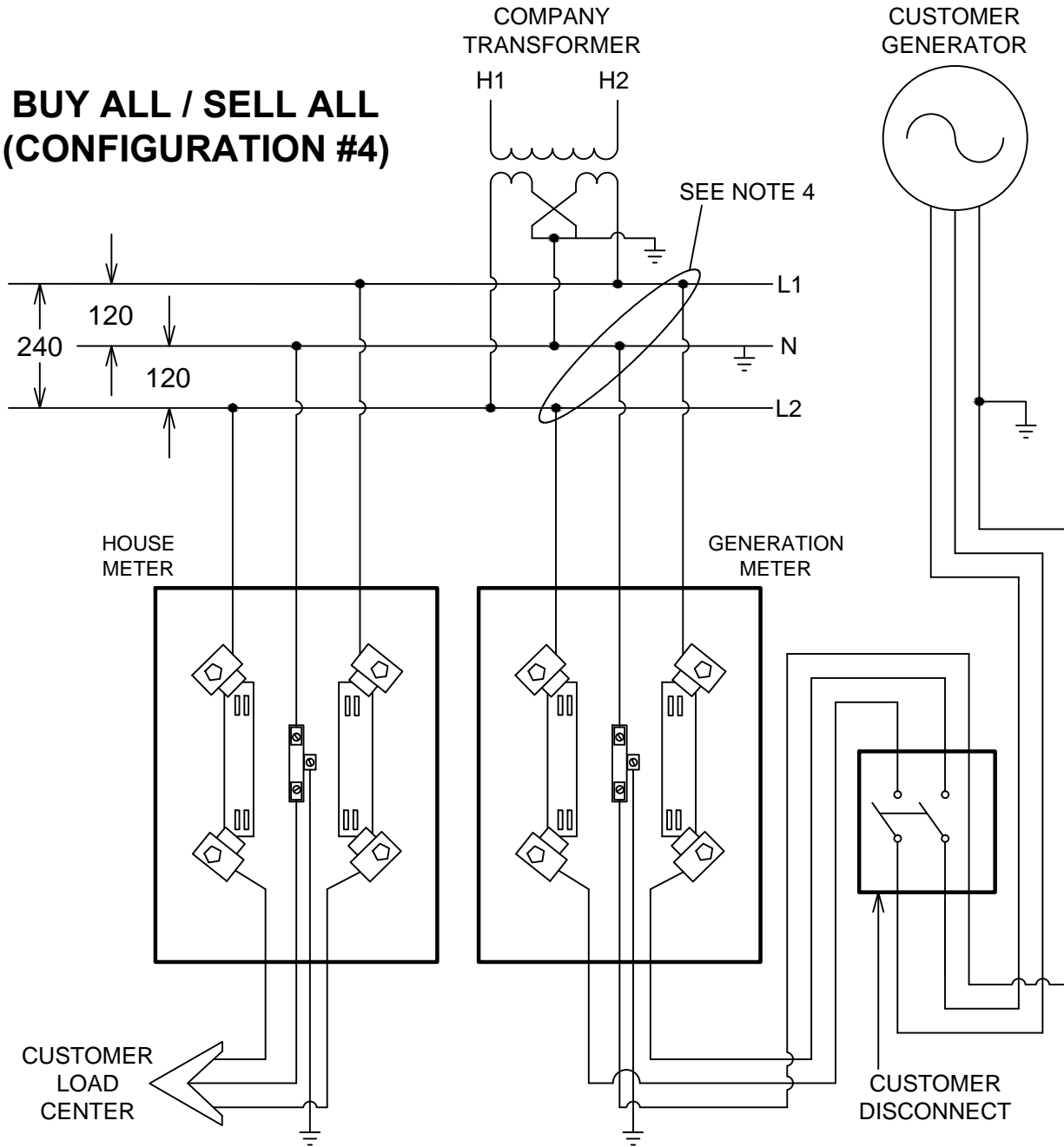

NOTES:

1. CUSTOMER GENERATOR CAN BE SOLAR, WIND OR OTHER QUALIFYING SYSTEM.
2. ALL EQUIPMENT MUST BE UL APPROVED, MEET IEEE STANDARDS AND COMPANY SAFETY REQUIREMENTS. INSTALLATION MUST MEET COMPANY, NEC, AND LOCAL CODE REQUIREMENTS.
3. GENERATION METER SOCKET AND DISCONNECT SWITCH MUST BE MARKED WITH PERMANENT LABELS (SUPPLIED BY COMPANY). STOCK CODE 080.7960.0380 (WARNING LABEL); STOCK CODE 080.7960.0376 (BUY ALL / SELL ALL LABEL).
4. UTILITY SIDE CONNECTIONS CANNOT BE MADE IN METER SOCKET; GANGED METER SOCKET IS ACCEPTABLE.

EFFECTIVE DATE:
04-29-19

**DISTRIBUTION CONSTRUCTION STANDARD
DOMINION ENERGY SOUTH CAROLINA, INC.**